

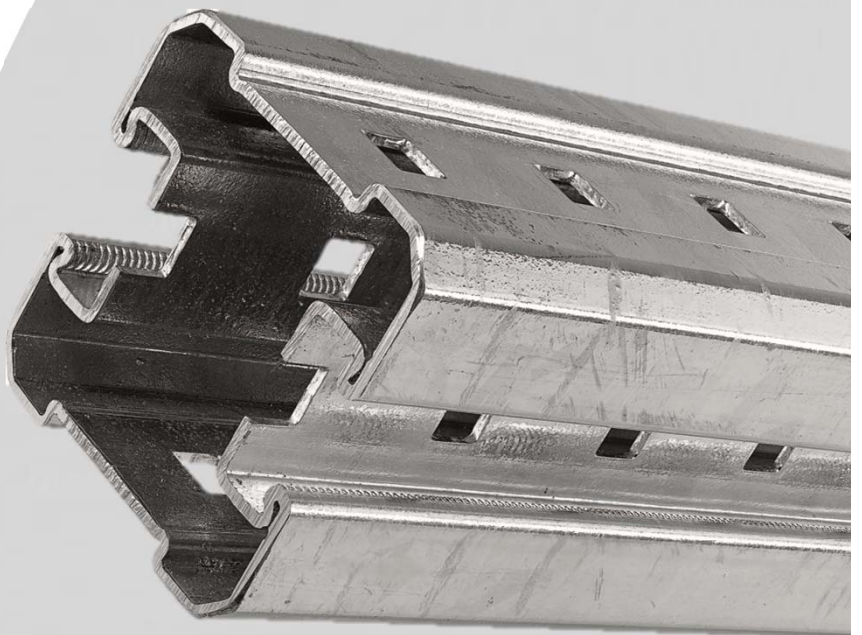

MIQC-90-L 2119868

Hilti North America
Installation Technical Manual
Technical Data
MIQ System

Version 1.0 06.2017



Terms of common cooperation / Legal disclaimer

The product technical data published in these Technical Data Sheets are only valid for the mentioned codes or technical data generation methods and the defined application conditions (e.g. ambient temperature load capacity not valid in case of fire, data not valid in support structures when mixed with third party products, values only apply to static loading conditions). Technical data applies to the component only -- suitability and capacity of all other components must be checked separately by the responsible engineer (e.g., other assembly components, attachments, base materials, and building structures).

Suitability of structures combining different products for specific applications needs to be verified by conducting a system design and calculation, using for example Hilti PROFIS software. In addition, it is crucial to fully respect the Instructions for Use and to assure clean, unaltered and undamaged state of all products at any time in order to achieve optimum performance (e.g. avoid misuse, modification, overload, corrosion).

As products but also technical data generation methodologies evolve over time, technical data might change at any time without prior notice. We recommend to use the latest technical data sheets published by Hilti.

In any case the suitability of structures combining different products for specific applications need to be checked and cleared by an expert, particularly with regard to compliance with applicable norms, codes, and project specific requirements, prior to using them for any specific facility. This book only serves as an aid to interpret the capacity of the components listed, without any guarantee as to the absence of errors, the correctness and the relevance of the results or suitability for a specific application. User must take all necessary and reasonable steps to prevent or limit damage. The suitability of structures combining different products for specific applications need to be confirmed with a professional designer and/or structural engineers to ensure compliance with User's specific jurisdiction and project requirements.

MIQC-90-L Connector

Designation	Item number
MIQC-90-L	2119868

Corrosion protection:

Hot dipped galvanized per DIN EN ISO 1461:

Connector:	2.2 mils (55 μm)
Bolt:	1.8 mils (45 μm)
Nut:	1.8 mils (45 μm)

Weight:

1.43lb (648g) incl. all components

Description:

Hilti angle, 90°, MIQ system, MIQC-90-L, Hot dipped galvanized, angle typically used for connection of two perpendicular Hilti MIQ girders, angle connector with two hole base plate fitted for connection in groove of other MIQ girder with two wing nuts, washers and self locking nuts (both included in the pack) on one side and with one hole fixed the same way on the other side, material weight 1.43 lb (648 g) incl. all connectivity material.

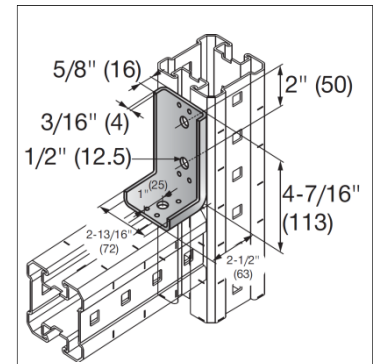

Connector's associated content

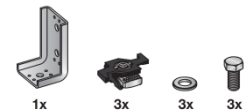

Material properties

Material	Yield strength	Ultimate strength	E-modulus	Shear modulus
Connector : S235JR - DIN EN10025-2 2005.4	$f_y = 34.08 \text{ ksi}$ (235 $\frac{N}{\text{mm}^2}$)	$f_u = 52.21 \text{ ksi}$ (360 $\frac{N}{\text{mm}^2}$)	29000 ksi (200000 $\frac{N}{\text{mm}^2}$)	11000 ksi (75845 $\frac{N}{\text{mm}^2}$)
Screw, prevail torque hex nut Class 8.8 - DIN EN 1993-1-8	$f_y = 92.82 \text{ ksi}$ (640 $\frac{N}{\text{mm}^2}$)	$f_u = 116.03 \text{ ksi}$ (800 $\frac{N}{\text{mm}^2}$)	29000 ksi (200000 $\frac{N}{\text{mm}^2}$)	11000 ksi (75845 $\frac{N}{\text{mm}^2}$)

Instruction For Use:

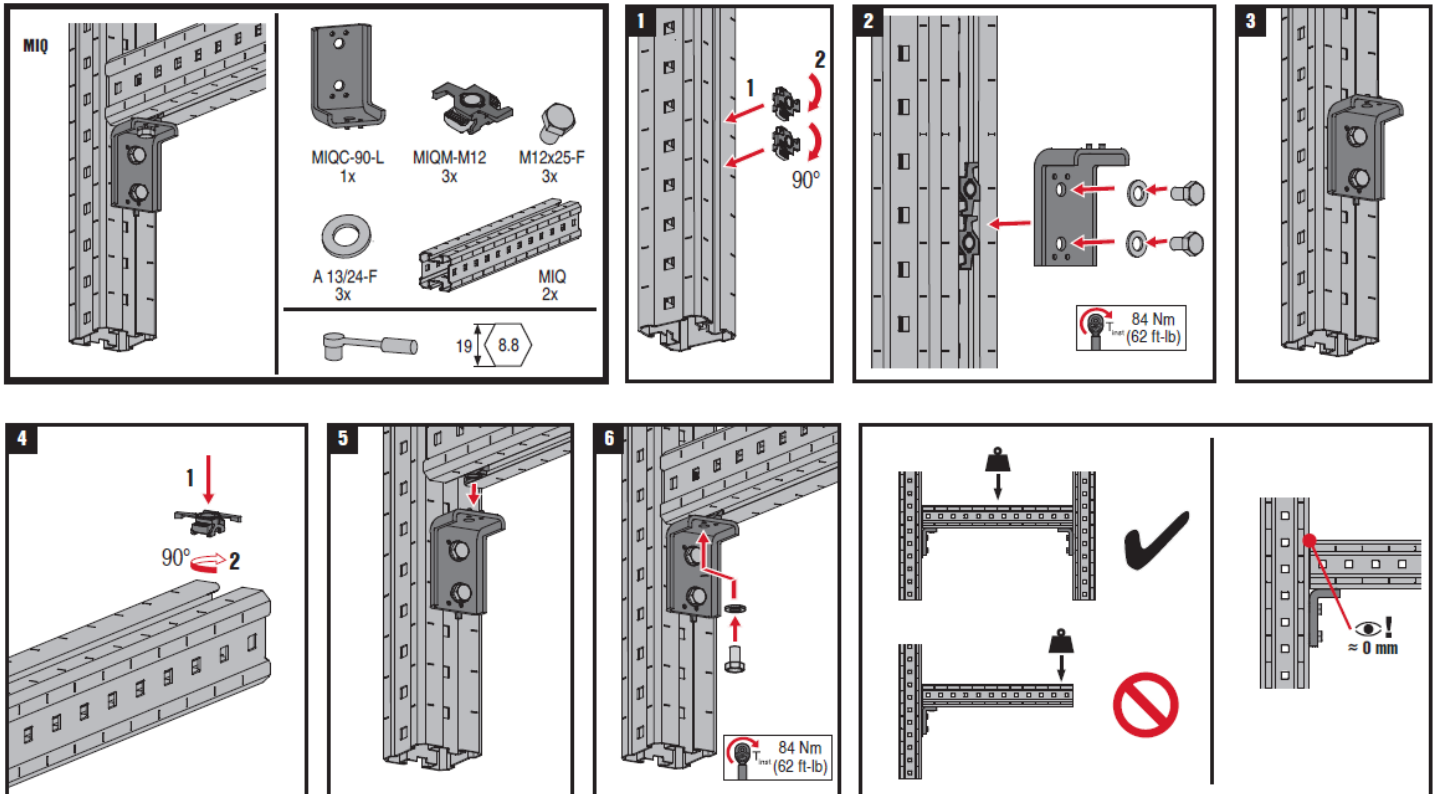

MIQC-90-L Connector

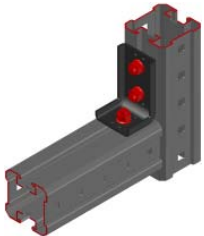
Approved loading cases		
Standard		
		

Governing Conditions

Methodology:

Connection strength values are determined with a combination of simulation (ANSYS), calculation (Microsoft Excel and Mathcad) and testing.

Standards and codes:

- ANSI/AISC 360-10 Specification for Structural Steel Buildings
- ANSI/AISC 360-10
– Appendix 1 Inelastic analysis
- AISI S100-2007/2010 North American Specification for the Design of cold formed Steel Structural Members
- EN 1993-1-1 Eurocode 3: Design of steel structures – Part 1-1: General rules and rules for buildings
- EN 1993-1-8 Eurocode 3: Design of steel structures – Part 1-8: Design of joints
- EN 10025-2 Hot rolled products of structural steels- Part 2: technical delivery conditions for non-alloy structural steels

Validity:

Temperature limits: -22°F (-30°C) to 200°F (+93°C).

Published allowable loads for applications are based on static loading conditions. Non-static forces, including those resulting from thermal or other expansion must be taken into account during design.

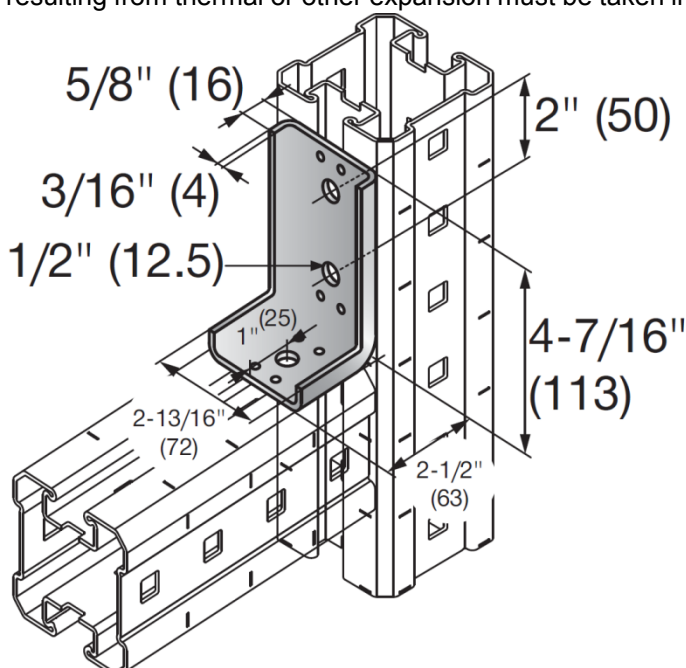

MIQC-90-L Connector

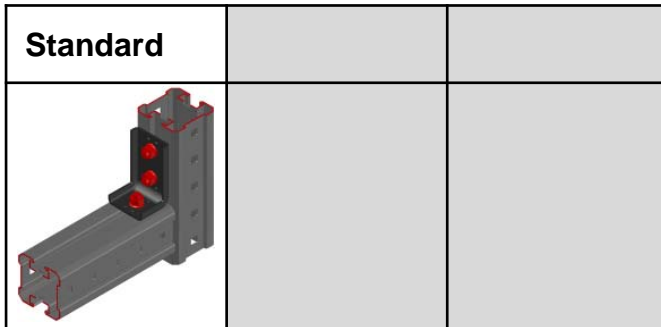

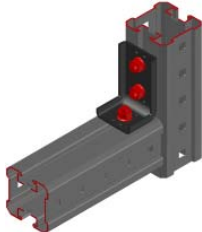
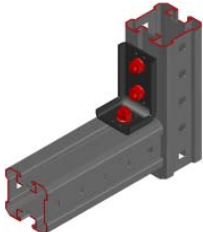
Loading case: Standard	Combinations covered by loading case
<p>Bill of Material for this loading case: For fixation on MIQ-90 girder Connector incl. all connecting hardware 1x MIQC-90-L 2119868</p> 	<p>Connector used for fixing horizontal-MIQ girder on grooved section of vertical-MIQ girder</p> 

Usage of Values for Design Strength and Allowable Strength

The Design Strength and Allowable Strength tables on the following pages include strength reduction factors:

- ASD:** Safety Factor (ω) > 1.0 as per AISC specifications.
- LRFD:** Strength Reduction Factor (ϕ) < 1.0 as per AISC specifications. $\Omega = \frac{1.5}{\phi}$ (Reference AISC 360 C-B3-5)

Factored loads are required for input to the given interaction equations. Factored loads are the responsibility of the user. Factored loads are noted as P, V and M

Limiting components of capacity evaluated in following tables:

- Connection system, including connector, hardware and affected portion of MIQ-90 girders, per FEA simulation

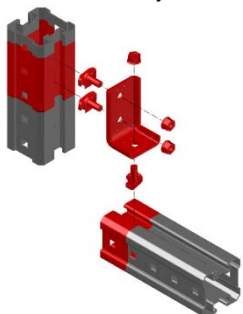

MIQC-90-L Connector

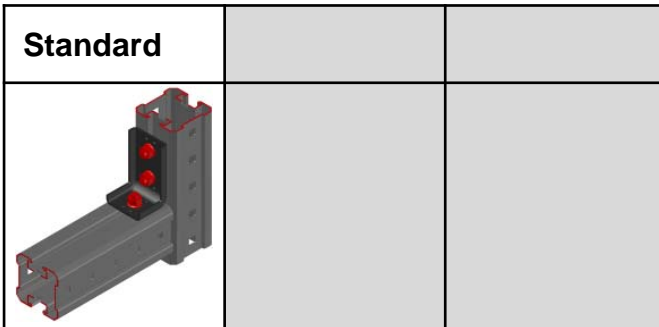

Values for Design Strength and Allowable Strength

1/1

NOTE: Calculate interaction separately for each group only using values from that group. Limiter is defined by highest interaction. Use absolute values. Values refer to the coordinate system shown.

1. Connection system, including connector, hardware and affected portion of MIQ-90 girders, per FEA simulation

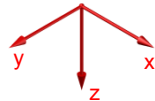
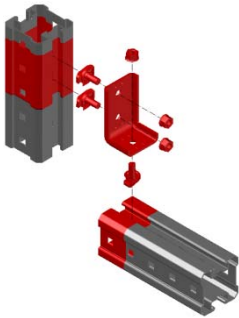

LRFD*	+Fx	-Fx	+Fy	-Fy	+Fz	-Fz
	[kip]	[kip]	[kip]	[kip]	[kip]	[kip]
	1.05	1.05	0.76	0.76	2.01	1.55
ASD*	+Mx	-Mx	+My	-My	+Mz	-Mz
	[kip*ft]	[kip*ft]	[kip*ft]	[kip*ft]	[kip*ft]	[kip*ft]
	0.17	0.17	0.00	0.00	0.00	0.00

Interaction for LRFD

$$\frac{P_{ux}}{F_x} + \frac{V_{uy}}{F_y} + \frac{V_{uz}}{F_z} + \frac{M_{ux}}{M_x} + \frac{M_{uy}}{M_y} + \frac{M_{uz}}{M_z} \leq 1$$

Interaction for ASD:

$$\frac{P_{ax}}{F_x} + \frac{V_{ay}}{F_y} + \frac{V_{az}}{F_z} + \frac{M_{ax}}{M_x} + \frac{M_{ay}}{M_y} + \frac{M_{az}}{M_z} \leq 1$$

*Values already include LRFD strength reduction (Φ) or ASD safety (Ω) factors in accordance with AISC, and are based on nominal geometry.



In the US:

Hilti, Inc. (U.S.)
P.O. Box 21148 Tulsa, OK 74121
Customer Service: 1-800-879-8000
en español: 1-800-879-5000
Fax: 1-800-879-7000

www.us.hilti.com

Hilti is an equal opportunity employer
Hilti is a registered trademark of Hilti, Corp.
©Copyright 2017 by Hilti, Inc. (U.S.)

In Canada:

Hilti (Canada) Corporation
2360 Meadowpine Blvd.
Mississauga, Ontario, L5N 6S2
Customer Service: 1-800-363-4458
Fax: 1-800-363-4459

www.hilti.ca

The data contained in this literature was current as of the date of publication. Updates and changes may be made based on later testing. If verification is needed that the data is still current, please contact the Hilti Technical Support Specialists at 1-800-879-8000 (U.S.) or 1-800-363-4458 (Canada). All published load values contained in this literature represent the result of testing by Hilti or test organizations. Local base materials were used. Because of variations in materials, on-site testing is necessary to determinate performance at any specific site.