



SEISMIC MANUAL

**Earthquake-resistant design
of MEP supports**

Version 1.3

FOREWORD

Non-structural does not mean non-essential. Despite not usually being treated with the same priority as structural elements, seismic design of non-structural elements such as building services, utilities and equipment can no longer be overlooked. Learning from the earthquakes of the last two decades, we can recognize two common consequences when non-structural elements are installed without seismic considerations:

1) **Significantly higher repair costs**

Especially in urban areas, earthquake damage and losses attributed to non-structural elements often exceeds that of structural systems.

2) **Suspension of essential services**

Continued operation after an earthquake is vital for hospitals, utilities, and many commercial and industrial production facilities. Even if the building primary structure (structural) withstands seismic activity as designed, generally the building cannot operate without non-structural installations for water supplies, telecommunication, etc.

Despite the possibility of the above consequences, the practical information available to Engineers about this subject remains limited. This handbook is meant to bring some assistance and guidance for anyone specifying seismic restraint installations and non-structural building members. Specifier, engineer, or designer will find design examples and solutions derived from the following three problems associated with the seismic performance of non-structural elements:

- 1) Non-structural elements could be considered more vulnerable to earthquakes due to the lack of seismic design
- 2) Higher cost needed for non-structural elements compared to structural systems
- 3) Non-structural elements tend to fail at lower seismic intensity levels than structural elements [Perrone et al., 2021]

Understanding these principles makes it possible for Consulting Engineers, Planners and other MEP Specialists to specify effective seismic restraint measures without first having to carry out an unreasonable amount of design and calculation work.

From: Hilti AG
BU Installation Systems
Feldkircherstrasse 100
9494 Schaan
Liechtenstein

Title: **Earthquake-resistant design of MEP supports.**
(Seismic Manual)

Version: 1.3 - EN

Summary: The document contains information and guidelines for the engineering and design of seismic restraints for non-structural installations according to EN 1998-1:2004 – Eurocode 8, NTC 18 circolare applicativa and SIA261. Installation systems for MEP, utilities, plant or equipment (non-structural building members) equipped with seismic resistant bracing are designed to transfer earthquake forces from the support structure to the main structure. The determinants for seismic design include the horizontal acceleration, the seismic risk of the site, and the characteristics of the building itself. The seismic hazard level varies significantly across Europe. As a result, the seismic forces which installations must be able to withstand are also subject to regional variations. The solutions you will find in this manual have been developed to address typical details for a variety of different resistance levels.

Place and date: Schaan, September 2021

CONTENT

1. Introduction	6
1.1 Seismicity in Europe	7
1.2 Seismicity in Italy	8
1.3 Code framework	9
2. Calculation of seismic actions	10
2.1 Non-structural elements	10
2.2 Equivalent static analysis	10
2.3 Calculation of seismic actions in accordance with EC8	11
2.4 Numerical example	15
3. Typical applications	17
3.1 Guide for the load capacity verification	17
3.2 Situation of seismic bracings in a pipe run	17
3.3 Collection of typical applications	19

1. INTRODUCTION

In recent years, more attention than ever has turned to the damage that earthquakes cause to the non-structural elements of buildings.

Elements such as machinery, façades, interior decoration, piping and distribution lines – if designed only for gravity – generally fail under the additional horizontal forces resulting from a low-intensity seismic event. Damage usually takes the form of fallen or broken pipes and power lines, and dislodged machinery (especially transformers and substations). As a consequence, non-structural elements without seismic capacity are often responsible for serious secondary effects after an earthquake:

- Fire and explosions, especially when flammable gases or electricity are nearby
- Pollution and release of poisonous substances
- Obstruction of escape routes
- Injuries due to falling and shifting elements
- Interrupted operations due to loss of utilities in buildings relevant to public safety
- Interrupted production

The cost of repairs have shown that the cost of repairs resulting from a seismic event are largely affected by the damage suffered by non-structural elements, with rates sometimes much higher than the damage suffered by the structure. For the seismic design of non-structural elements, the seismic hazard of the site and specifics of the building in question are decisive.

As a rule, dead loads and working loads dominate when calculating load-bearing structures and their fastenings. The same applies to non-structural fixtures, equipment and installations: only the forces acting vertically due to weight are usually taken into account. As no continuous or variable forces are considered to act in a horizontal direction, the resistance to horizontal forces is often considerably smaller. Therefore, it should be no surprise that the typical damage caused by earthquakes must be attributed to the effect of extraordinary horizontal forces.

1.1 Seismicity in Europe

The following illustration (Fig. 1.1) provides an overview of seismicity in Europe.

The seismic hazard map shows the peak ground acceleration for stiff ground and 10% probability of exceedance in 50 years (475 year return period).

Seismic activity is particularly prevalent in the Mediterranean region - in Italy, the Balkans, Greece and Turkey.

Elevated levels of seismicity are also apparent in the Alps, on the Iberian peninsula and in parts of North Africa.

Northern Europe, and also Germany and France tend to have lower seismicity.

In Central Europe, a slightly elevated seismic hazard is particularly noticeable in the Rhine region.

Macro-seismic intensities and seismic hazards for each of the individual countries are shown in the national guidelines.

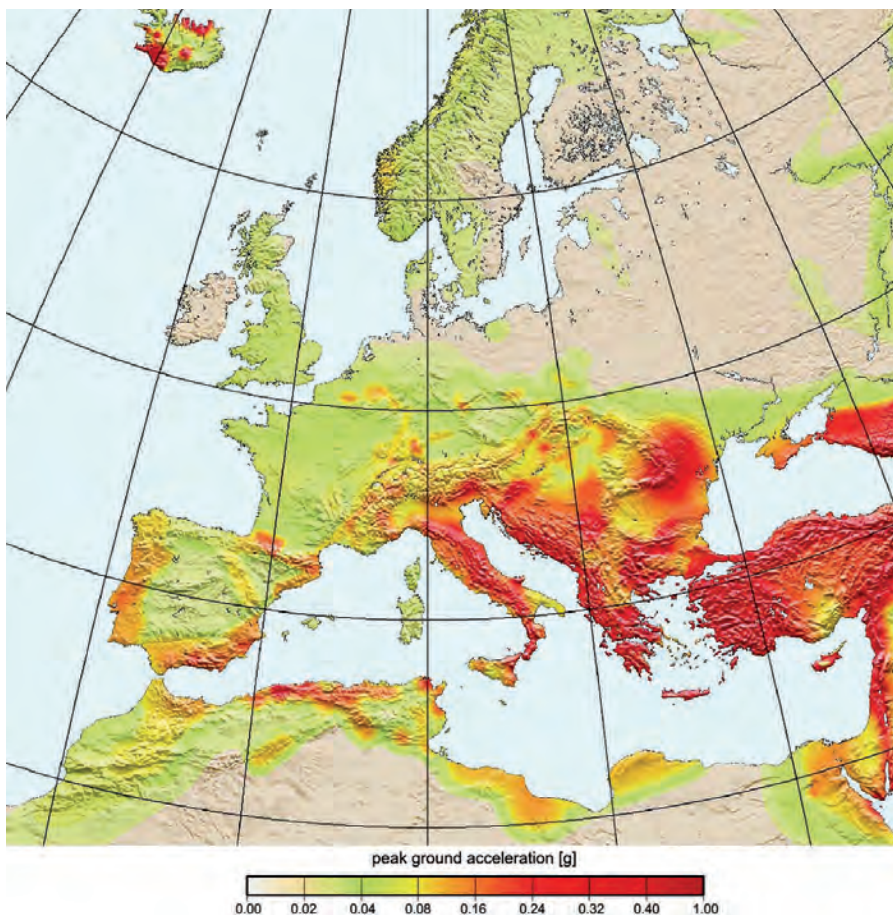

Fig. 1.1 – European seismic hazard map

1.2 Seismicity in Italy

Italy is one of the most seismic countries in the Mediterranean area, both for the frequency of earthquakes that have historically affected this territory and for the intensity that some of them have achieved.

The figure below gives an overview of macro-seismic intensity in Italy. Intensity is a qualitative measure of earthquake strength.

Macroseismic intensity refers to the effects of an earthquake that are perceptible without instruments. Effects on human perception, geology and buildings are typical examples of macroseismicity.

The physical values such as peak ground acceleration used to quantify the earthquake impact (and which have to be used in a design of earthquake resistant installation systems) are described in Fig. 1.2.

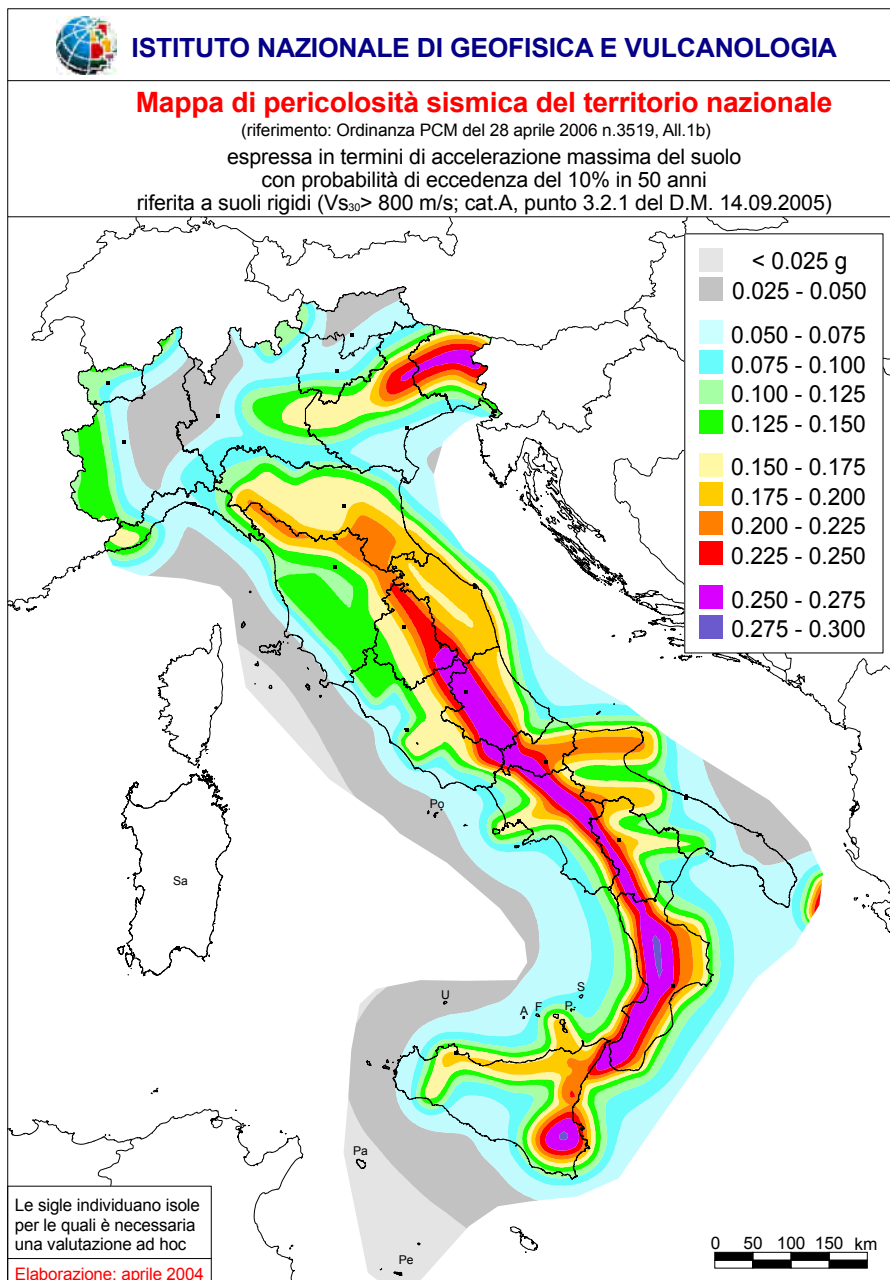

Fig. 1.2 – Peak ground acceleration according to “Ordinanza PCM no. 3519-2006”

1.3 Code framework

1.3.1 Eurocodes / EN1998

The European standards, known as Eurocodes, are recognized as high-quality, coherent construction standards. National annexes consider the national specificities of the European member states and provide, for example the local hazard maps that indicate the peak ground accelerations.

Whenever the EN Eurocodes are used for a supporting framework or structure, the national annex for the country in which the supporting framework is to be erected is required.

The list of NDPs (Nationally Determined Parameters) is given in the preface to each part of the EN Eurocode.

The EN 1998 series (Eurocode 8) deals with earthquake resistance. The standard is divided into different sections:

Part 1 of Eurocode 8 – the EN 1998-1 standard¹ – applies to the design of structures for earthquake resistance. The standard is subdivided into 10 sections, of which a number are specifically dedicated to the design of buildings. They contain the fundamental performance requirements and compliance criteria applicable for design of non-structural elements in buildings in earthquake areas.

In addition to EN 1998-1, supplementary rules are necessary for certain types of supporting framework, which are dealt with in EN 1998-2 to EN 1998-6. They are contained in these sections of Eurocode 8:

- EN 1998-2 contains special regulations for bridges;
- EN 1998-3 contains regulations for the assessment and improvement of earthquake resistance of existing buildings;
- EN 1998-4 contains special regulations for silos, storage tanks and pipelines;
- EN 1998-5 contains special regulations relating to foundations, retaining structures and geotechnical aspects;
- EN 1998-6 contains special regulations for towers, masts and chimneys.

In the absence of local regulations in countries outside of Europe, the Eurocode 8 could be used as reference for the seismic design of non-structural elements.

1.3.2 Italian Code NTC 18 / Circolare Applicativa

Since March 2018, the National Building Code NTC 18 is mandatory in Italy, legally enforced by law 1086/71.

In general, NTC 18 defines seismic actions, design methods and verifications to be considered for specific applications. Installation systems are in scope of the NTC 18 too. They are treated as non-structural elements.

The seismic action on non-structural elements is defined under §7.2.3 of NTC 2018.

This paragraph refers to the seismic action parameter S_a (seismic action coefficient) and q_a (seismic behavior factor).

Formulas to calculate S_a can be found in the Circolare Applicativa of the new NTC (approved on January 21st, 2019) and Eurocode 8. Both are applicable.

1.3.3 Swiss Code SIA 261

SIA structural standard 261: 2014 Art. 16.7 requires seismic design of secondary components as well as their connections and anchoring, specifically when these components endanger people, damage the supporting structure or impair the operation of important systems.

The SIA standards are not declared as binding in all Swiss cantons but are considered to be current and are - unless other standards such as the SN EN standards are used - therefore to be regarded as binding.

The logic for seismic design according to SIA 261 is fully in line with Eurocode 8.

¹ EN 1998-1:2004 Design of structures for earthquake resistance - Part 1: General rules, seismic actions and rules for buildings

2. CALCULATION OF SEISMIC ACTIONS

2.1 Non-structural elements

Installations and fittings that do not form part of the supporting framework of buildings are described as non-structural elements. Non-structural elements are installations and facades or suspended ceilings such as building claddings. Installations and equipment such as pipelines, apparatus and machinery, machines or photovoltaic installations are also designated as non-structural elements.

If non-structural elements have to be designed and secured so as to be earthquake resistant, the decisive factor for the design and dimensioning is not the movement of the ground (ground acceleration or a_g) but that of the building / floor. Here the decisive floor acceleration a_f is dependent on the building, which transmits the floor movements during an earthquake (Fig. 2.1).

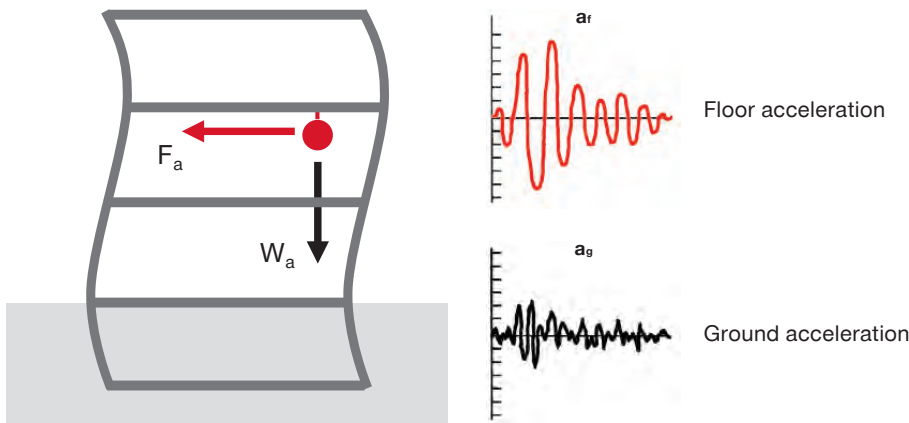

Fig. 2.1- Equivalent static analysis for the determination of earthquake actions on non-structural elements

The building support structure amplifies the ground vibrations. Especially frequencies close to the building fundamental frequency are increased.

2.2 Equivalent static analysis

The above-mentioned relationships involve complex dynamic processes which are considered with elaborate dynamic simulations. However, simulations of this type are costly. For this reason this elaborate technique is only used to demonstrate the earthquake resistance of non-structural elements in exceptional cases, such as for nuclear power station components.

Non-structural elements are normally designed using the equivalent static force method.

In this case, an equivalent static force (seismic force) F_a acting on the element's center of gravity is determined.

With that, the dynamic building and non-structural element behavior is simplified and considered by various factors (coefficients).

2.3 Calculation of seismic actions in accordance with EC8

2.3.1 General form

According to EN 1998-1, the horizontal seismic force (equivalent static force) F_a acting on a non-structural element at the center of mass, is calculated as follows:

$$F_a = \frac{\gamma_a}{q_a} \cdot S_a \cdot W_a$$

where:

F_a	horizontal seismic force	[kN]
W_a	weight of the non-structural element	[kN]
S_a	seismic coefficient of the non-structural element	[-]
γ_a	importance factor of the non-structural element	[-]
q_a	behavior factor of the non-structural element	[-]

2.3.2 Importance factor

γ_a is the importance factor of the non-structural element. It is not a physical value, but a risk-oriented factor (that is to say a safety factor).

EN 1998-1:2004 states under clause 4.3.5.3 that the importance factor γ_a shall not be less than 1.5 for the following non-structural elements:

- Anchoring of machines and equipment required for life safety systems
- Tanks and containers holding toxic or explosive substances that pose a danger to the public

In all other cases, the importance factor of non-structural elements may be assumed to be $\gamma_a = 1.0$.

2.3.3 Behavior factor

Ductile systems can dissipate energy. For such systems, the seismic force can be reduced via the behavior factor q_a within the equation for F_a . For structures, in order to use a behavior factor of $q_a > 1.0$ at the ultimate limit state, the energy dissipation capacity must be demonstrated and quantified which includes large amount of analysis or testing efforts. For some groups of non-structural elements EN 1998-1:2004 chapter 4.3.5.4 sets out maximum values for the behavior factor q in following table.

Type of non-structural element	q_a
<ul style="list-style-type: none"> • Cantilevering parapets or ornamentations • Signs and billboards • Chimneys, masts and tanks on legs acting as unbraced cantilevers along more than one half of their total height 	1.0
<ul style="list-style-type: none"> • Exterior and interior walls • Partitions and facades • Chimneys, masts and tanks on legs acting as unbraced cantilevers along less than one half of their total height, or braced or guyed to the structure at or above their center of mass • Anchorage elements for permanent cabinets and book stacks supported by the floor • Anchorage elements for false (suspended) ceilings and light fixtures 	2.0

Table 2.1 – Values of q_a for non-structural elements in accordance with EN 1998-1:2004

Installation supports are not explicitly mentioned in this table. However, the general logic is that if ductile behavior can be expected for a certain group of non-structural elements, the behavior factor $q_a = 2.0$ is linked with it. “Anchorage elements for false (suspended) ceilings and light fixtures” are stated in this second group of elements. They are similar to installation support elements.

In EN 1992-4:2018 Table C.2 q_a -values for non-structural elements are stated. The categories

- “Computer access floors, electrical and communication equipment“ (line 9);
- “High pressure piping, fire suppression piping” (line 13); and
- “Fluid piping for non-hazardous materials” (line 14)

are all related to $q_a = 2.0$.

Only for installation systems related to “Hazardous material storage, hazardous fluid piping” $q_a = 1.0$ is given.

	Type of non-structural element	q_a
1	Cantilevering parapets or ornamentalions	
2	Signs and billboards	
3	Chimneys, mats and tanks on legs acting as unbraced cantilevers more than one half of their total height	1.0
4	Hazardous material storage, hazardous fluid piping	
5	Exterior and interior walls	
6	Partitions and facades	
7	Chimneys, mats and tanks on legs acting as unbraced cantilevers along less than one half of their total height, or braced or guyed to the structure at or above their center of mass	
8	Elevators	
9	Computer access floors, electrical and communication equipment	
10	Conveyors	2.0
11	Anchorage elements for permanent cabinets and book stacks supported by the floor	
12	Anchorage elements for false (suspended) ceilings and light fixtures	
13	High pressure piping, fire suppression piping	
14	Fluid piping for non-hazardous materials	
15	Computer, communication and storage racks	

Table 2.2 – Values of q_a for non-structural elements in accordance with EN 1992-4:2018 Table C.2

This is fully in line with information on the behavior factor, which can be found in other parts of Eurocode 8 such as EN 1998-4. This applies to silos, storage tanks and pipelines and information is available on the behavior factor for welded steel pipelines. In this case, a behavior factor $q_a = 1.5-3.0$ is indicated, depending on the pipe geometry.

The general application of $q_a = 2.0$ for the seismic design of Hilti installation systems is recommended based on above mentioned sections from Eurocodes.

Only for hazardous material storage and hazardous fluid piping should $q_a = 1.0$ be used.

2.3.4 Seismic coefficient

EN 1998-1:2004 requires that the seismic coefficient S_a be determined on a location-specific basis as follows.

It is determined from the seismic hazard and the amplification factor (see below).

$$S_a = \frac{a_g}{g} \cdot S \cdot \left[3 \cdot \frac{(1 + z/H)}{1 + (1 - T_a/T_1)^2} - 0.5 \right] = \frac{a_g}{g} \cdot S \cdot A$$

S_a	seismic coefficient of the non-structural element	[-]
a_g	design ground acceleration for type A ground	[m/s ²]
S	soil factor	[-]
z	height of the non-structural element (from the building foundation level)	[m]
H	height of the building (from the building foundation level)	[m]
T_a	fundamental vibration period of the non-structural element	[s]
T_1	fundamental vibration period of the building (in the direction concerned)	[s]
A	amplification factor	[-]

2.3.5 Seismic hazard

The term contained in the equation for the seismic coefficient S_a of the non-structural element

$$\frac{a_g}{g} \cdot S$$

takes into account the design ground acceleration a_g and the soil factor S , thereby describing the seismic hazard at a particular location.

The design ground acceleration a_g is determined on a country-by-country basis according to the local seismic hazard and may be found in the relevant national annex to EN 1998-1 (EN 1998-1/NA) or in the national guidelines.

According to EN 1998-1:2004, ground classes A, B, C, D and E can be described in the following table.

The recommended soil factor S for these ground classes is also given. In order to take account of the influence of local building and subsoil conditions, the parameter values in a particular country may also be specified in the national annex.

In this case, the ground classification scheme specified in the national annex, taking into account the subsurface geology of an individual country, also contains a definition of the soil factor S . If the influence of the subsurface geology is not taken into account, EN 1998-1:2004 recommends the use of two response spectra (type 1 and type 2).

If the earthquakes which essentially define the seismic hazard in a particular location have surface wave magnitudes M_s not exceeding 5.5, use of the type 2 spectrum is recommended.

Table 2.3 – Recommended ground class and soil factor **S** according to EN 1998-1:2004

Ground class	Description	Recommended soil factor S according to EN 1998-1:2004	
		Response spectrum type 1	Response spectrum type 2
A	Rock or similar rock-like geological formation, with no more than 5 m of softer material on the surface	1.00	1.00
B	Deposits of very dense sand, gravel of very stiff clay, with a thickness of at least a few tens of meters characterised by a gradual increase in mechanical properties with increasing depth	1.20	1.35
C	Deep deposits of dense or medium density sand, gravel or stiff clay, with thicknesses of between a few of meters to several hundred meters	1.15	1.50
D	Deposits of loose-to-medium density non-cohesive soil (with or without a few soft cohesive layers), or predominantly soft to stiff cohesive soil	1.35	1.80
E	A soil profile consisting of a surface alluvial layer with v_s values as per C or D and variable thickness between around 5 m and 20 m above stiffer soil material with $v_s > 800$ m/s	1.40	1.60

2.3.6 Amplification factor **A**

The amplification factor **A** is used to take into account the amplification in acceleration of the non-structural element with increasing height (z/H) relative to the building height as well as the amplification through resonance effect. This means when the fundamental vibration period of the non-structural element (T_a) and the fundamental vibration period of the building (T_1) are close to each other, accelerations of the non-structural element are increasing.

$$A = \left[3 \cdot \frac{(1 + z/H)}{1 + (1 - T_a/T_1)^2} - 0.5 \right]$$

The fundamental vibration period T_a is a function of mass and stiffness of the non-structural element. Generally, the physical formula

$$T = 2\pi \sqrt{\frac{m}{c}}$$

applies also for installation systems. Hilti Profis MSE software allows fully automatic assessment of the fundamental period of our modular support system.

Without detailed analysis always $T_a/T_1 = 1$ can be conservatively assumed.

The amplification factor **A** can vary widely between following values:

- stiff non-structural element ($T_a/T_1 \approx 0$) at foundation level of the building ($z/H \approx 0$): $A = 1.0$
- non-structural element in resonance with building ($T_a/T_1 = 1$) on the roof of the building ($z/H \approx 1$): $A = 5.5$

2.4 Numerical example

The section below is a simplified example of the calculation of the horizontal seismic force acting on a mass hanging from a concrete slab, considering a hypothetical case of an installation of a single pipe with mass w (kg/m) fixed at a distance h (m) from the ceiling. The objective is to identify the main parameters that influence the calculation of seismic force and obtain, finally, a real calculation according to the static analysis-equivalent.

2.4.1 Input

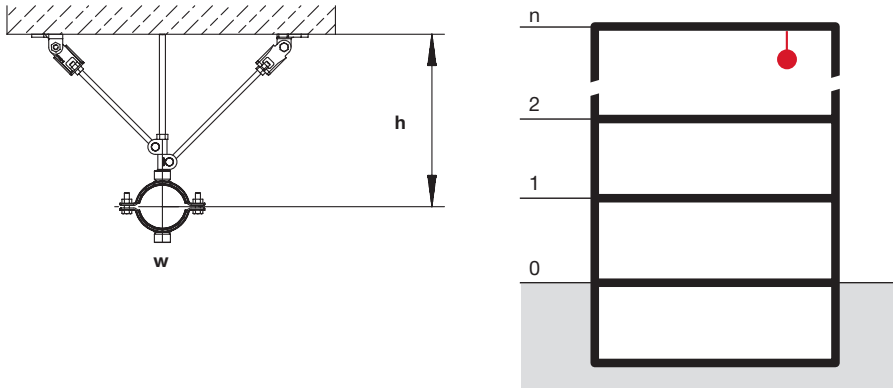

Pipe weight	$w = 10$ kg/m	(steel pipe DN50, full of water, with insulation)
Distance from ceiling	$h = 0.25$ m	(from intrados to the center of gravity of the pipe)
Installation spacing	$l_{static} = 2.00$ m	(distance between the pipe fastenings in the pipe run)

According to EC8, the horizontal seismic load is

$$F_a = \frac{\gamma_a}{q_a} \cdot S_a \cdot W_a$$

The seismic coefficient S_a must be determined on a country-by-country basis according to the local seismic hazard, taking account of the influence of local building and subsoil conditions (relevant national annex or the national guidelines must be observed).

$$S_a = \frac{a_g}{g} \cdot S \cdot \left[3 \cdot \frac{(1 + z/H)}{1 + (1 - T_a/T_1)^2} - 0.5 \right] = \frac{a_g}{g} \cdot S \cdot A$$

Assuming for example that:

$a_g = 2.42$ m/s ²	(example for a medium-seismicity area in Italy)
$S = 1.35$	(example for ground class B, spectrum type 2 - see table 2.2)
$z/H = 1$	(pipe installed on the top floor of the building - see picture above)
$T_a/T_1 = 1$	(conservative assumption)

the seismic factor A is equal to 5.5 and, finally, the seismic coefficient $S_a = 1.80$

2.4.2 Evaluation of the horizontal seismic load

The importance factor γ_a and the behavior factor can be assumed q_a as follow:

$\gamma_a = 1$	(non-structural element, without function for vital systems)
$q_a = 2$	(braced installation system – see Table 2.1)

So, the horizontal seismic force is

$$F_a = \frac{\gamma_a}{q_a} \cdot S_a \cdot W_a = \frac{1}{2} \cdot 1.80 \cdot w \cdot i_{seismic} = 0.90 \cdot 0.10 \text{ kN/m} \cdot i_{seismic} = 0.090 \cdot i_{seismic}$$

where $i_{seismic}$ is the distance between supports with the same type of bracing – in this example, it is the distance between two pipe supports with transversal bracing. It is supposed to alternate the seismic support between transversal set-up and longitudinal set-up (see **Section 3.2** for more details on the bracing's configuration in a pipe run):

$$i_{seismic} = 2 \cdot i_{static} = 4 \text{ m}$$

As a consequence, the seismic load acting on the braced pipe support is

$$F_a = 0.090 \cdot i_{seismic} = 0.090 \cdot 4 = 0.36 \text{ kN}$$

2.4.3 Evaluation of actions on seismic bracing

Considering the following structural scheme and neglecting the brace 2, subject to compression alone, it's possible to determine easily the seismic actions S1 and S3, acting on the brace 1 and the vertical rod respectively.

Assuming $\alpha = 45^\circ$ we deduce

$$S1 = \frac{F_a}{\sin \alpha} = 0.509 \text{ kN}$$

$$S3 = W - \frac{F_a}{\tan \alpha} = w \cdot i_{static} - \frac{F_a}{\tan \alpha} = -0.16 \text{ kN}$$

The brace 1 is therefore subject to a tensile force equal to 0.509 kN, considering the horizontal seismic load $F_a = +0.36 \text{ kN}$.

It's evident that the seismic action, by definition, can act in both directions ($\pm F_a$). As a consequence, brace 2 is necessary to absorb the horizontal seismic action in the opposite direction: $F_a = -0.36 \text{ kN}$.

The vertical threaded rod is subject to a compression force of -0.16 kN.

In this case it is necessary to fulfil a buckling proof of the vertical threaded rod (automatically calculated by Profis MSE software) or to stiffen the rod with reinforcements (see **Annex D** for more details on the use of rod stiffeners).

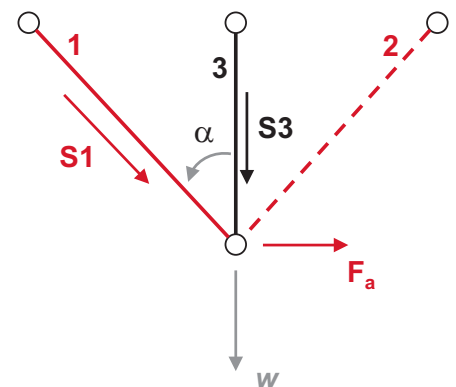

Fig. 2.2- Structural scheme of actions on seismic bracing

3. TYPICAL APPLICATIONS

3.1 Guide for the load capacity verification

- 1 Calculation of horizontal seismic loading F_a (see **Chapter 2**) to get horizontal forces E_x and E_y (longitudinal and transversal). E_z can be neglected according EN 1998-1; 4.3.3.5.2 and 4.3.5.2.
 $F_a / E_x / E_y$ = design values

- 2 Choose – out of the typical collection – the actual load case:
Longitudinal / Transversal / 4-way

- 3 Consider/check on the boundary conditions, whatever is relevant for your particular applications:
 - max H, max L (see notes on Typical)
 - angle brace limitation (**Annex A**)
 - structural attachment (**Annex B**)
 - right pipe ring (**Annex C**)
 - rod stiffener requirement (**Annex D**)

- 4 Compare actual load F_a with the max. design load F_{horiz} (longitudinal and transversal) mentioned on typical drawing:
 $F_a \leq F_{horiz}$ (**max. design load**)

- 4a For single pipe bracing, the design capacity is according to typical charts

- 4b For trapeze with rod bracing and trapeze with channel bracing, please contact Hilti for our Calculation Service

3.2 Situation of seismic bracings in a pipe run

Braces for an earthquake-resistant installation need to be arranged at a distance (b) from each other that must be assessed in relation to seismic acceleration, the mass of the pipes (or system in general) and the type of braces itself.

We can distinguish three basic types of seismic braces.

- **Longitudinal bracing:** seismic brace arranged longitudinally to the main direction of the plant – resistance to horizontal actions acting along the main axis of the pipe.
- **Transversal bracing:** seismic brace perpendicular to the main direction of the media – resistance to horizontal actions acting transversely of the pipe.
- **4-way bracing:** structure composed of both longitudinal and transversal braces resistance to actions in both horizontal directions.

It is advantageous for the bracing to be at a spacing that is a multiple of the normal pipe fastening spacing of (s), so that, for example, every third or fourth pipe fastening is braced.

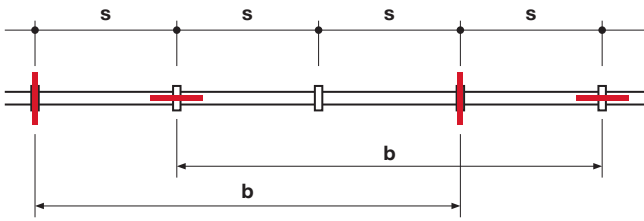

Fig. 3.1 – Bracing arranged transversely and longitudinally in relation to pipe axis and at spacing of b in each case

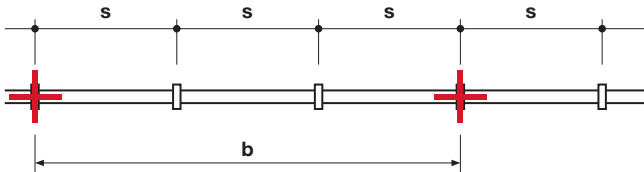

Fig. 3.2 – Transversal and longitudinal bracing on the same pipe fastening – 4-way bracing

Where the pipe changes direction, particular care is necessary to ensure that bracing is not provided in one direction only (Fig. 3.3). In such cases it can sometimes be necessary to arrange identical sets of bracing one after another along the pipe axis (Fig.3.4).

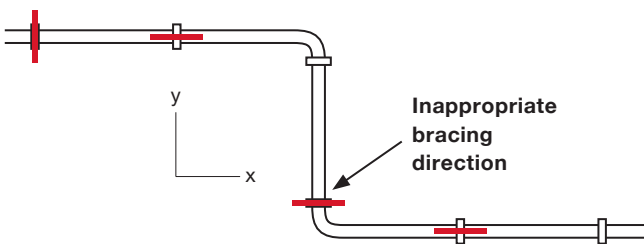

Fig. 3.3 – Inappropriate arrangement of bracing (none in y direction)

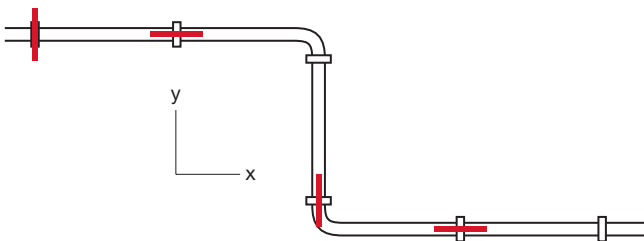

Fig. 3.4 – Horizontal forces in y direction taken by longitudinal bracing

NFPA13 and EN12845 Annex E indicate spacing design restrictions. For straight lines, the maximum longitudinal spacing of bracings is 24m and the maximum transversal spacing is 12m. From pipe ends, the pipes should be transversally braced within 2m and longitudinally braced within 12m.

At perpendicular corners, transversal braces within 0.6m from the corner can be considered as longitudinal braces of the perpendicular direction.

3.3 Collection of typical applications

Single pipe

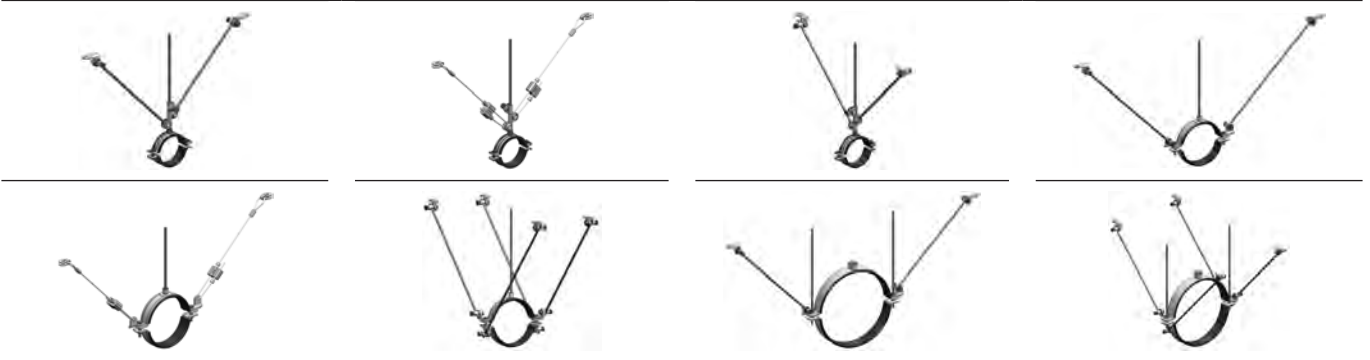

Trapeze – seismic bracing with rods and wires

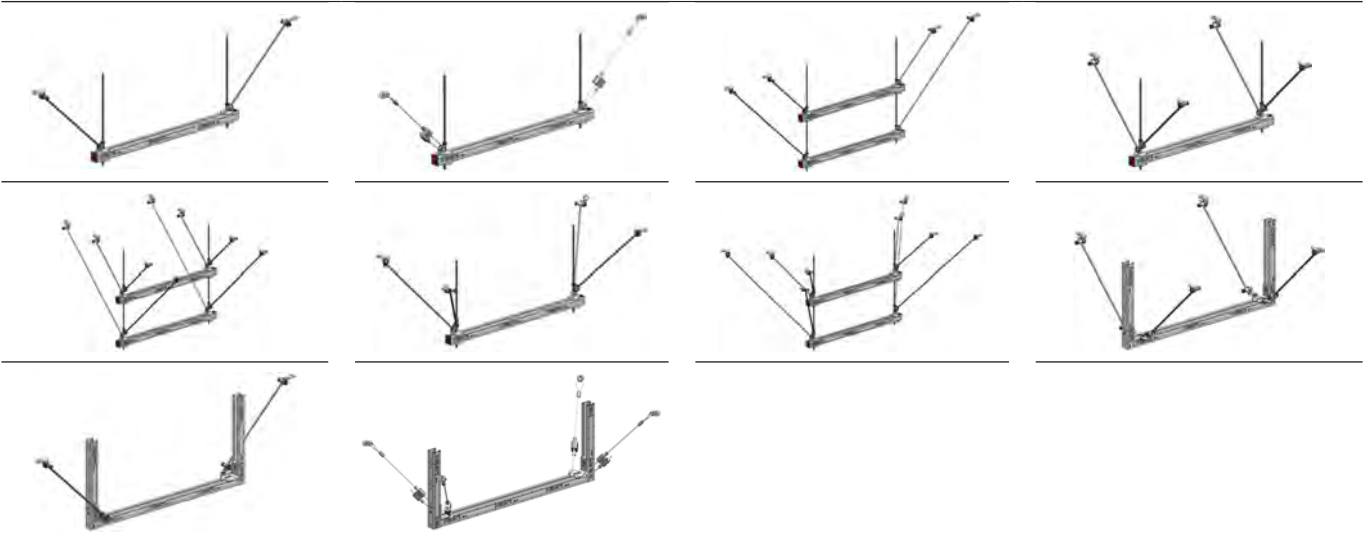

Trapeze – seismic bracing with channels

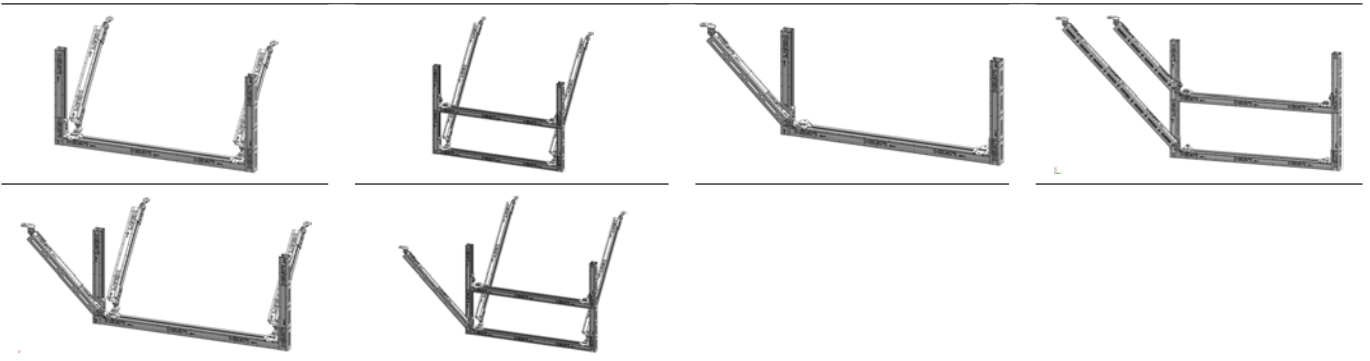

Wall bracket



Ventilation system with rod bracing

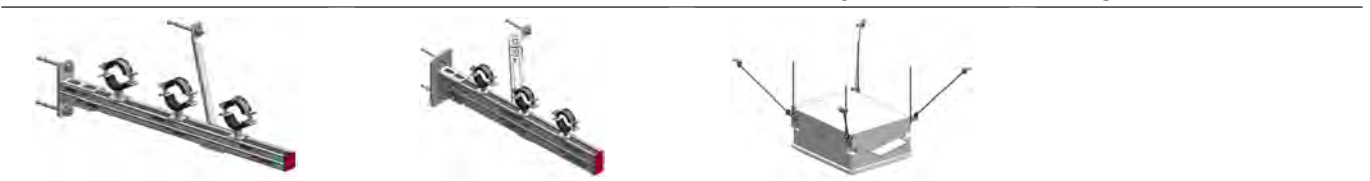

SINGLE PIPE WITH ROD BRACING

Transversal bracing; Support type: R-SP-T

Max. design load (seismic horizontal) in [N]	
Longitudinal [Y]	Transversal [X]
- 0 -	- 800 -

Seismic load orientation

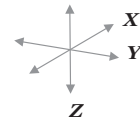

See Annex B for structural attachments
for anchorage

(*) Threaded rod (AM8x...)/AM10x...
item no. according rod length

Seismic hinge Hilti MQS-AP -8 / -10 / -12
item no. 2330874 / 2330875 / 2330876

Threaded rod Hilti AM10x...
item no. according to rod length

Additional seismic hinge Hilti
MQS-HR -8 / -10 (only for
retrofit application)
item no. 2330877 / 2330878

Seismic hinge Hilti MQS-HR -8 / -10
item no. 2330877 / 2330878

(**) Hilti pipe ring
 ϕ pipe $\leq 4"$

General Design Notes

Design loads are stated in this paper are depending on following conditions:

- (*) using M8, M10 ; for retrofit applications only M10 vertical rod is allowed
- (**) for relevant pipe rings – see Annex C
- brace angle: $45^\circ \pm 15^\circ$ – See Annex B
- structural attachments – see Annex B



MQS System

Seismic Designed Solutions

Hilti strongly advises consulting a Structural Engineer to verify that the design and products comply with applicable regulations and standards. The published data is a typical application the suitability for a specific project, design, or jobsite must be assessed by the Engineer of Record for the project. All product's must be strictly used according to the manufacturer's instructions for use and within the application limits as published. The relevant application limits may not be exceeded at any time. All rights reserved by Hilti AG. Duplication, utilization and disclosure of drawings are not permitted unless expressly agreed by Hilti AG.

SINGLE PIPE WITH WIRE BRACING

Transversal bracing; Support type: R-SPW-T

Max. design load (seismic horizontal) in [N]	
Longitudinal [Y]	Transversal [X]
- 0 -	- 800 -

Seismic load orientation

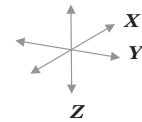

See Annex B for structural attachments
for anchorage

(*) Threaded rod (AM8x...)/AM10x...
item no. according to rod length

Clip MW-C
Please refer to catalog pages for
product information

Lock MW-L and wire rope with loop
Please refer to catalog pages for
product information

**Additional seismic hinge Hilti
MQS-HR -8 / -10 (only for
Retrofit application)**
item no. 2330877 / 2330878

Seismic hinge Hilti MQS-HR -8 / -10
item no. 2330877 / 2330878

(**) Hilti pipe ring
 \varnothing pipe \leq 4"

General Design Notes

Design loads are stated in this paper are depending on following conditions:

- (*) using M8, M10 ; for retrofit applications only M10 vertical rod is allowed
- (**) for relevant pipe rings – see Annex C
- brace angle: $45^\circ \pm 15^\circ$ – See Annex B
- structural attachments – see Annex B



MQS System

Seismic Designed Solutions

Hilti strongly advises consulting a Structural Engineer to verify that the design and products comply with applicable regulations and standards. The published data is a typical application the suitability for a specific project, design, or jobsite must be assessed by the Engineer of Record for the project. All product's must be strictly used according to the manufacturer's instructions for use and within the application limits as published. The relevant application limits may not be exceeded at any time. All rights reserved by Hilti AG. Duplication, utilization and disclosure of drawings are not permitted unless expressly agreed by Hilti AG.

SINGLE PIPE WITH ROD BRACING

Longitudinal bracing; Support type: R-SP-L

Max. design load (seismic horizontal) in [N]	
Longitudinal [Y]	Transversal [X]
- 800 -	- 0 -

Seismic load orientation

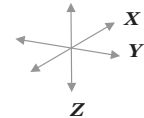

See Annex B for structural attachments for anchorage

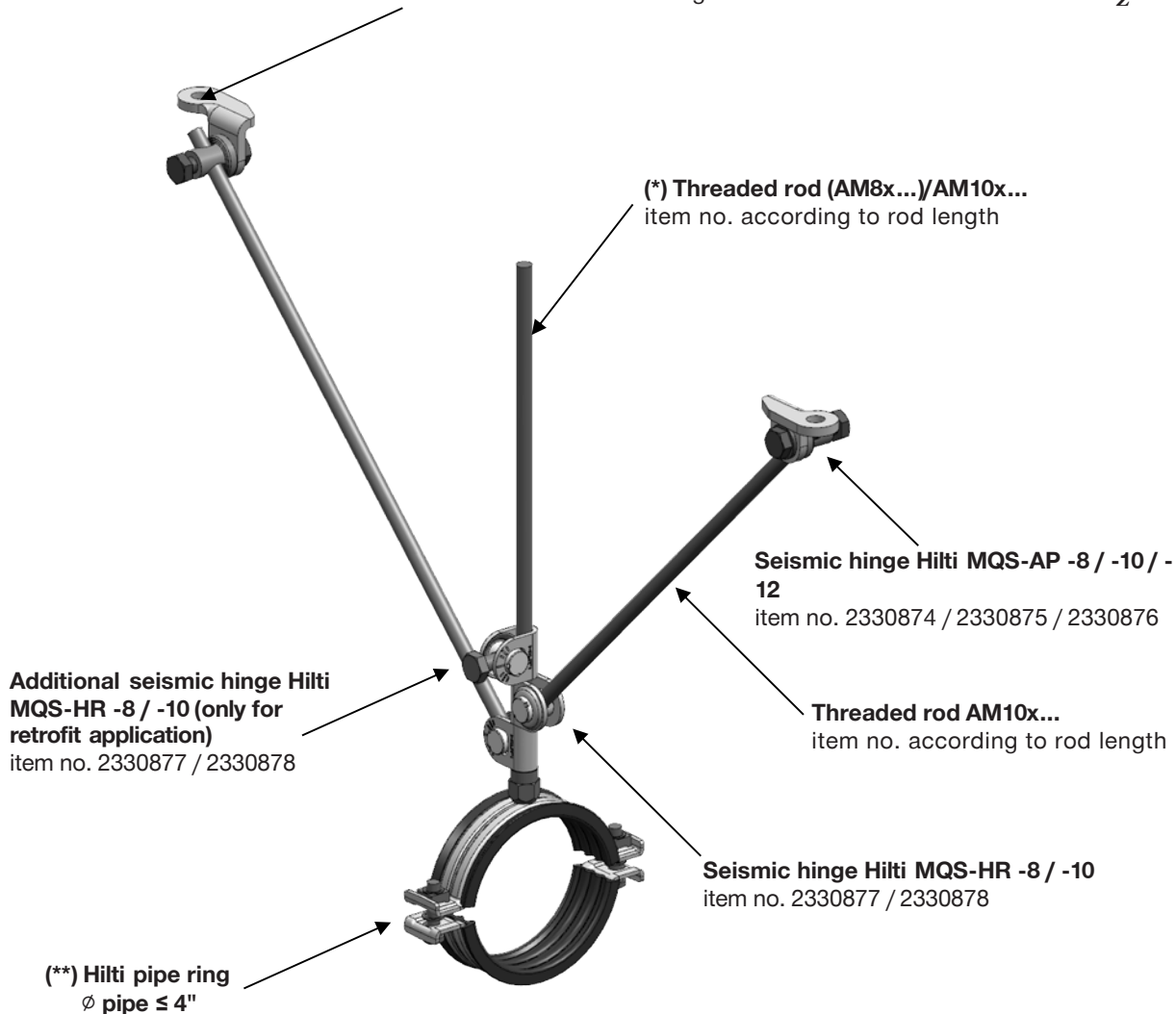

General Design Notes

Design loads are stated in this paper are depending on following conditions:

- (*) using M8, M10 ; for retrofit applications only M10 vertical rod is allowed
- (**) for relevant pipe rings – see Annex C
- brace angle: $45^\circ \pm 15^\circ$ – See Annex B
- structural attachments – see Annex B



MQS System

Seismic Designed Solutions

Hilti strongly advises consulting a Structural Engineer to verify that the design and products comply with applicable regulations and standards. The published data is a typical application the suitability for a specific project, design, or jobsite must be assessed by the Engineer of Record for the project. All product's must be strictly used according to the manufacturer's instructions for use and within the application limits as published. The relevant application limits may not be exceeded at any time. All rights reserved by Hilti AG. Duplication, utilization and disclosure of drawings are not permitted unless expressly agreed by Hilti AG.

SINGLE PIPE WITH ROD BRACING

Transversal bracing; Support type: R-SP-TD

Max. design load (seismic horizontal) in [N]	
Longitudinal [Y]	Transversal [X]
- 0 -	- 1500 -

Seismic load orientation

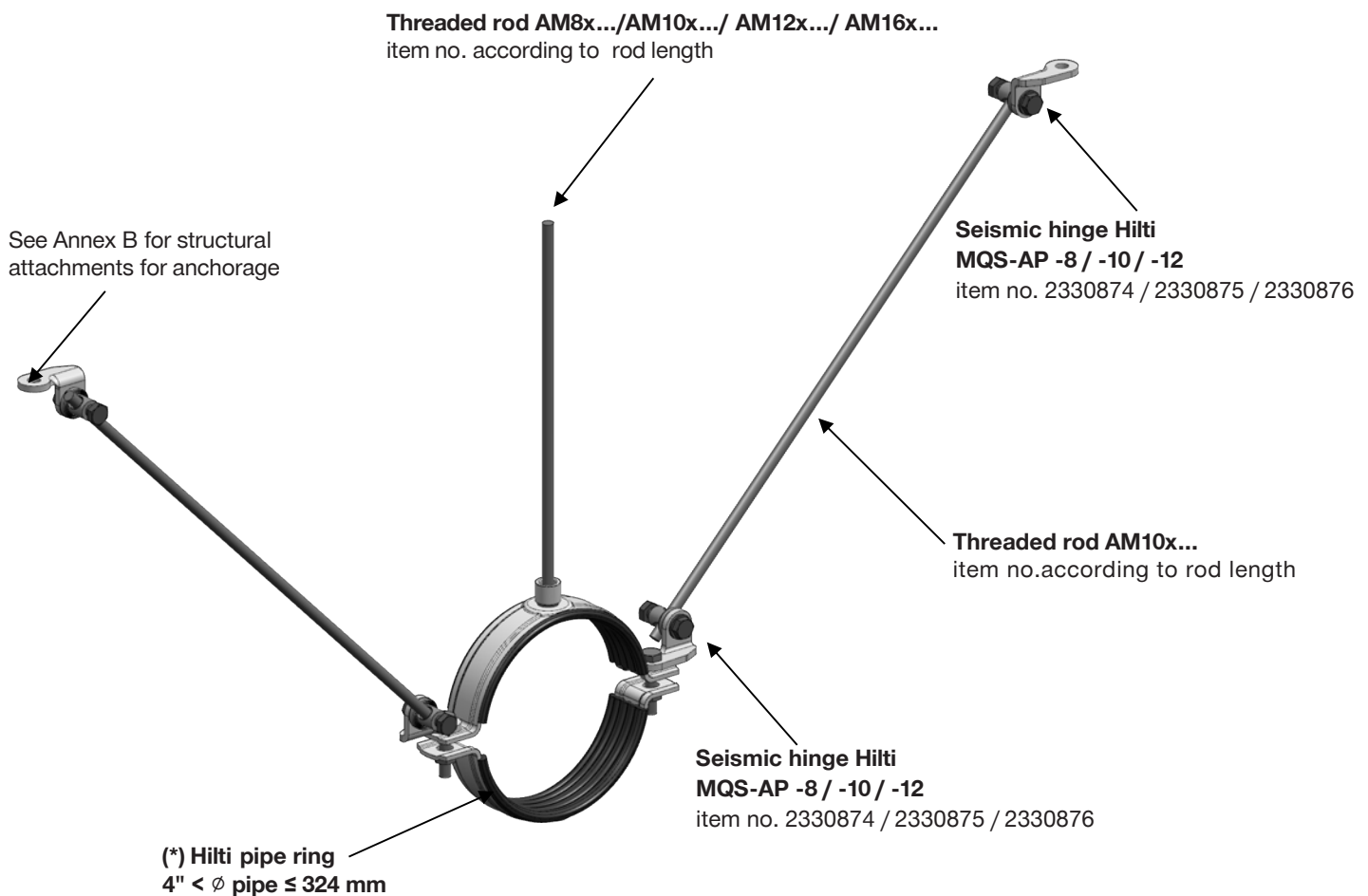
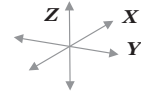

General Design Notes

Design loads are stated in this paper are depending on following conditions:

- (*) for relevant pipe rings – see Annex C
- brace angle: $45^\circ \pm 15^\circ$ – See Annex B
- structural attachments – see Annex B

MQS System

Seismic Designed Solutions

Iti strongly advises consulting a Structural Engineer to verify that the design and products comply with applicable regulations and standards. The published data is a typical application the suitability for a specific project, design, or jobsite must be assessed by the Engineer of Record for the project. All product's must be strictly used according to the manufacturer's instructions for use and within the application limits as published. The relevant application limits may not be exceeded at any time. All rights reserved by Hilti AG. Duplication, utilization and disclosure of drawings are not permitted unless expressly agreed by Hilti AG.

SINGLE PIPE WITH WIRE BRACING

Transversal bracing; Support type: R-SPW-TD

Max. design load (seismic horizontal) in [N]	
Longitudinal [Y]	Transversal [X]
- 0 -	- 1500 -

Seismic load orientation

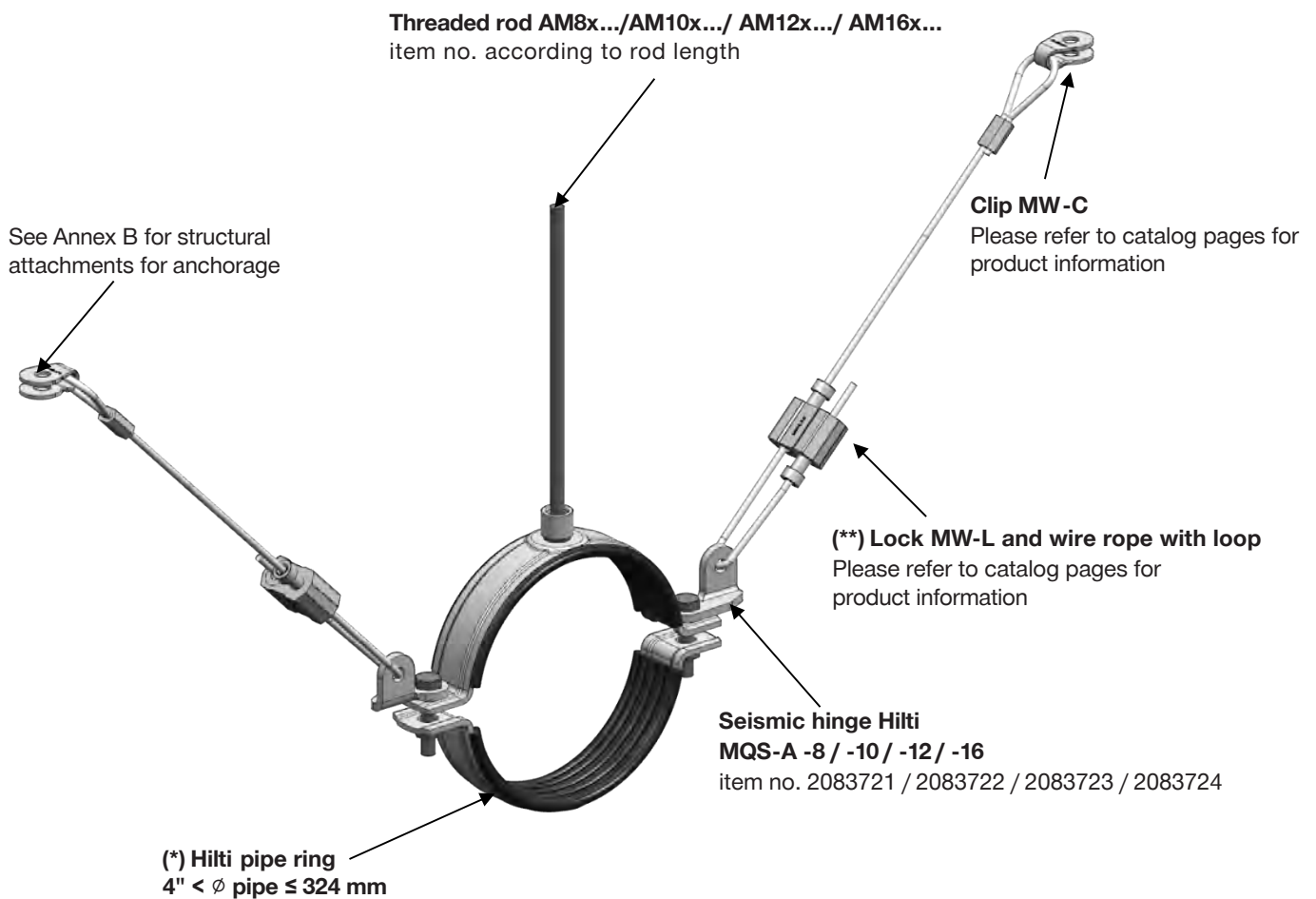
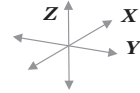

General Design Notes

Design loads are stated in this paper are depending on following conditions:

- (*) for relevant pipe rings – see Annex C
- (**) for MW-L 2mm seismic design resistance is limited to 2.21kN
- brace angle: $45^\circ \pm 15^\circ$ – See Annex B
- structural attachments – see Annex B

MQS System

Seismic Designed Solutions

Hilti strongly advises consulting a Structural Engineer to verify that the design and products comply with applicable regulations and standards. The published data is a typical application the suitability for a specific project, design, or jobsite must be assessed by the Engineer of Record for the project. All product's must be strictly used according to the manufacturer's instructions for use and within the application limits as published. The relevant application limits may not be exceeded at any time. All rights reserved by Hilti AG. Duplication, utilization and disclosure of drawings are not permitted unless expressly agreed by Hilti AG.

SINGLE PIPE WITH ROD BRACING

Longitudinal bracing; Support type: R-SP-LD

Max. design load (seismic horizontal) in [N]	
Longitudinal [Y]	Transversal [X]
- 1500 -	- 0 -

Seismic load orientation

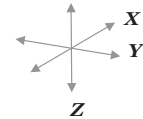

See Annex B for structural attachments for anchorage

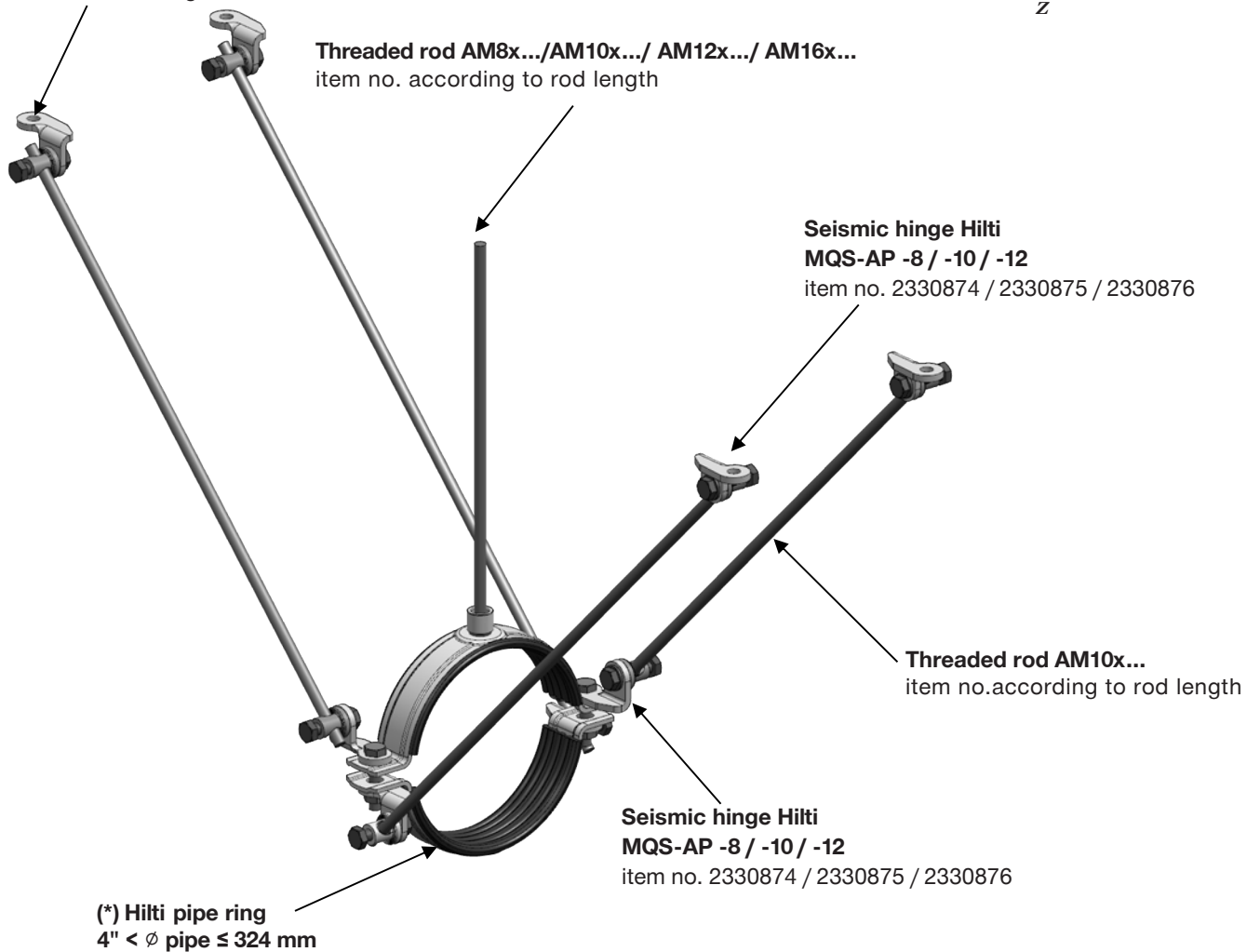

General Design Notes

Design loads are stated in this paper are depending on following conditions:

- (*) for relevant pipe rings – see Annex C
- brace angle: $45^\circ \pm 15^\circ$ – See Annex B
- structural attachments – see Annex B

MQS System

Seismic Designed Solutions

Iti strongly advises consulting a Structural Engineer to verify that the design and products comply with applicable regulations and standards. The published data is a typical application the suitability for a specific project, design, or jobsite must be assessed by the Engineer of Record for the project. All product's must be strictly used according to the manufacturer's instructions for use and within the application limits as published. The relevant application limits may not be exceeded at any time. All rights reserved by Hilti AG. Duplication, utilization and disclosure of drawings are not permitted unless expressly agreed by Hilti AG.

SINGLE PIPE WITH ROD BRACING

Transversal bracing; Support type: R-SP-TDL

Max. design load (seismic horizontal) in [N]	
Longitudinal [Y]	Transversal [X]
- 0 -	- 2800 -

Seismic load orientation

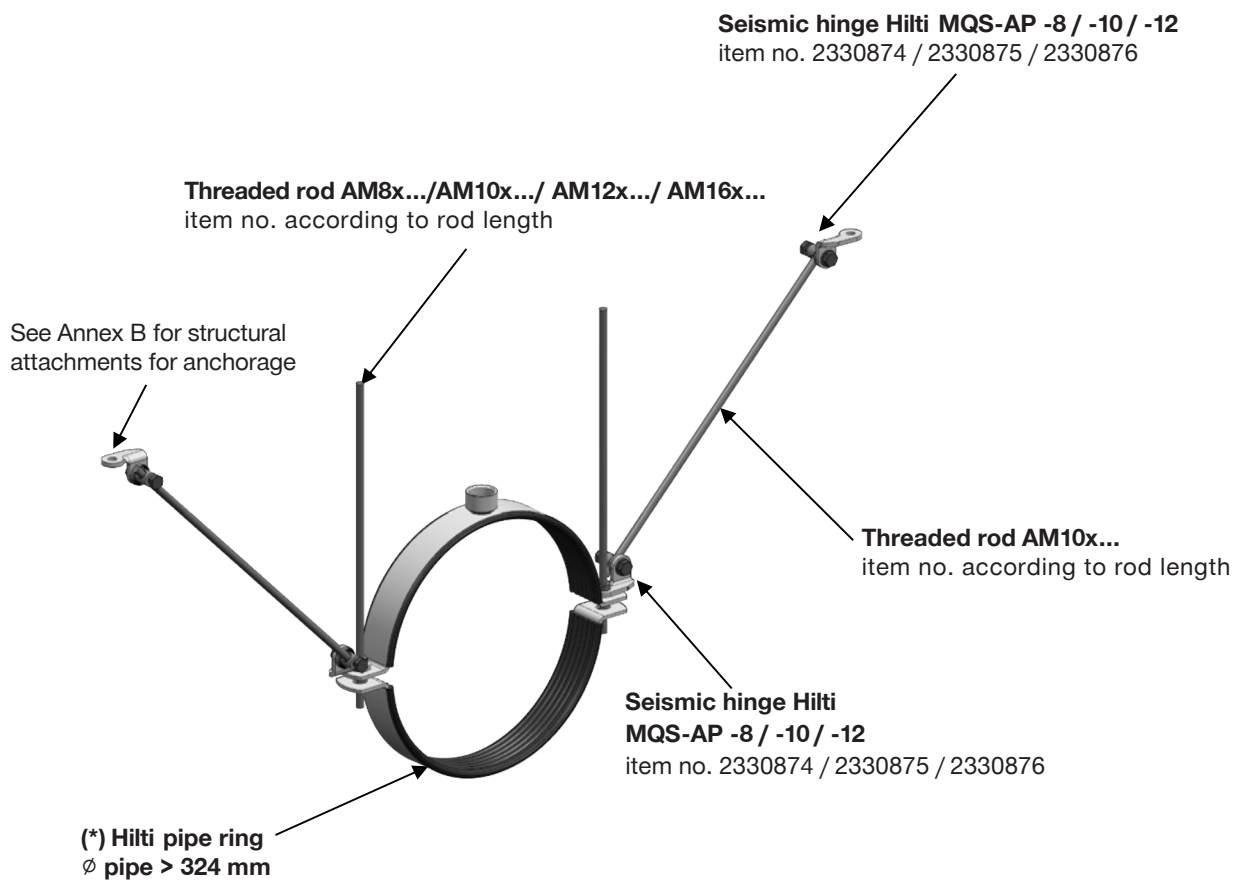
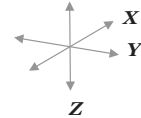

General Design Notes

Design loads are stated in this paper are depending on following conditions:

- (*) for relevant pipe rings – see Annex C
- brace angle: $45^\circ \pm 15^\circ$ – See Annex B
- structural attachments – see Annex B

MQS System

Seismic Designed Solutions

Hilti strongly advises consulting a Structural Engineer to verify that the design and products comply with applicable regulations and standards. The published data is a typical application the suitability for a specific project, design, or jobsite must be assessed by the Engineer of Record for the project. All product's must be strictly used according to the manufacturer's instructions for use and within the application limits as published. The relevant application limits may not be exceeded at any time. All rights reserved by Hilti AG. Duplication, utilization and disclosure of drawings are not permitted unless expressly agreed by Hilti AG.

SINGLE PIPE WITH ROD BRACING

Longitudinal bracing; Support type: R-SP-LDL

Max. design load (seismic horizontal) in [N]	
Longitudinal [Y]	Transversal [X]
- 2800 -	- 0 -

Seismic load orientation

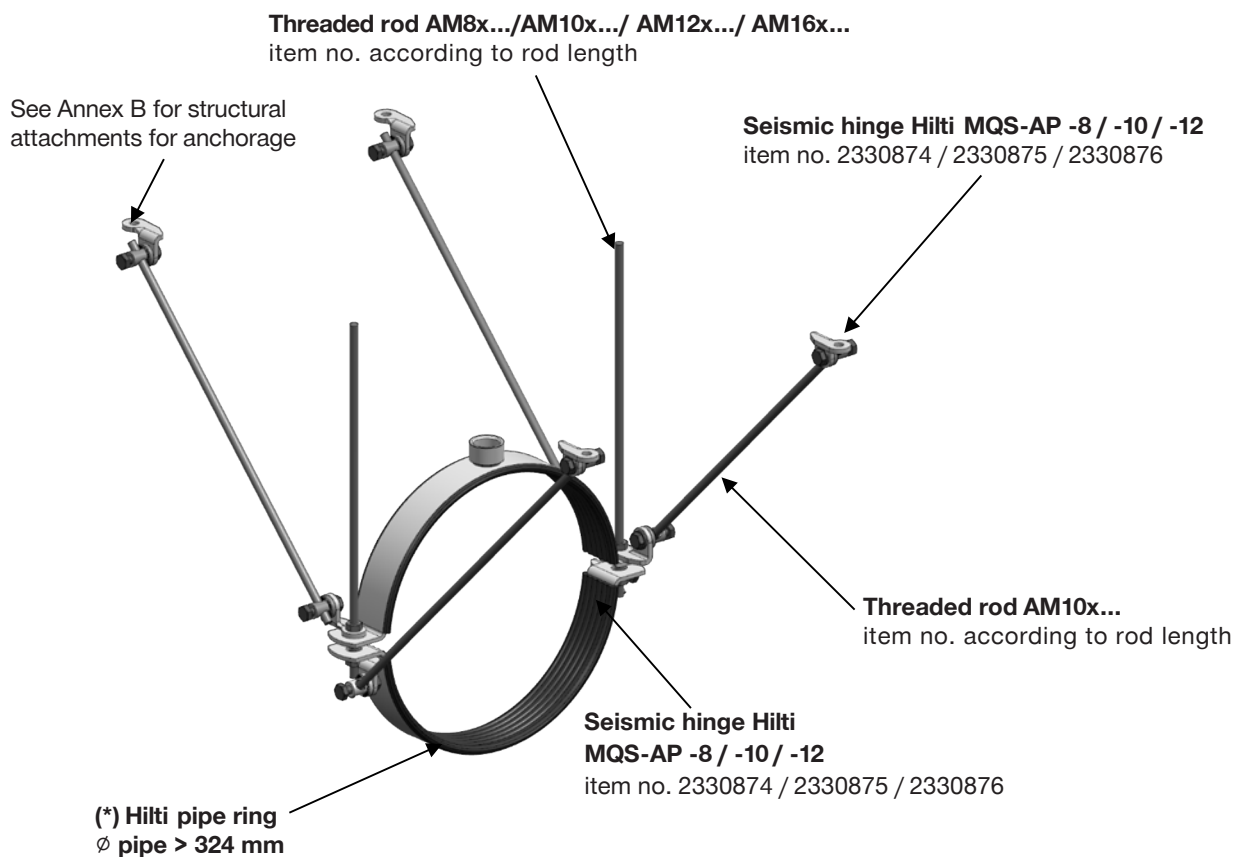
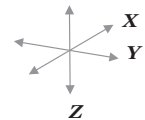

General Design Notes

Design loads are stated in this paper are depending on following conditions:

- (*) for relevant pipe rings – see Annex C
- brace angle: $45^\circ \pm 15^\circ$ – See Annex B
- structural attachments – see Annex B

MQS System

Seismic Designed Solutions

Iti strongly advises consulting a Structural Engineer to verify that the design and products comply with applicable regulations and standards. The published data is a typical application the suitability for a specific project, design, or jobsite must be assessed by the Engineer of Record for the project. All product's must be strictly used according to the manufacturer's instructions for use and within the application limits as published. The relevant application limits may not be exceeded at any time. All rights reserved by Hilti AG. Duplication, utilization and disclosure of drawings are not permitted unless expressly agreed by Hilti AG.

TRAPEZE WITH ROD BRACING

Transversal bracing; Support type: R-TPS-T

Max. design load (seismic horizontal) in [N]	
Longitudinal [Y]	Transversal [X]
Calculation with PROFIS is needed	

Seismic load orientation

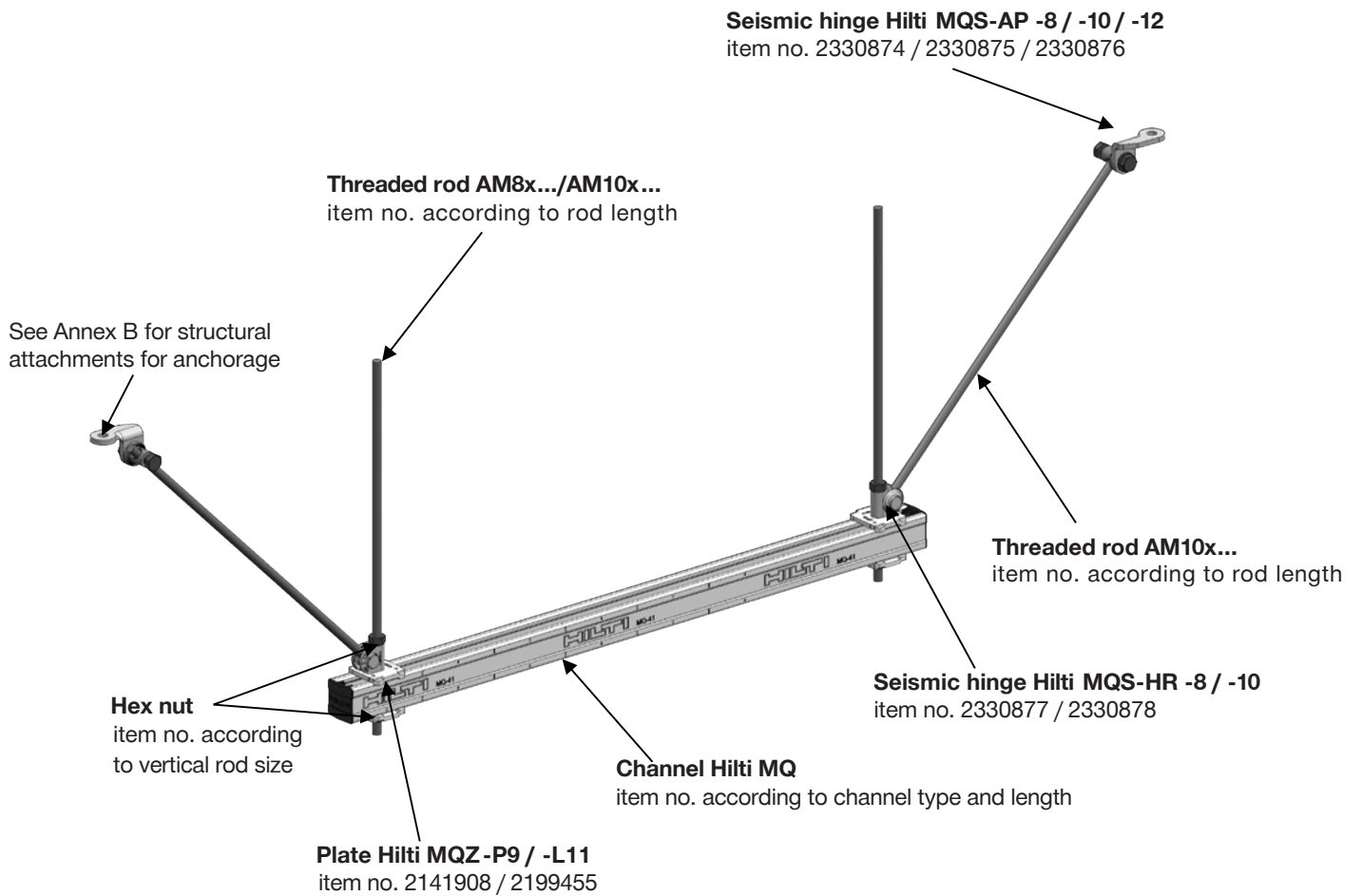
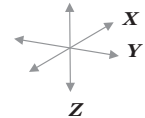

General Design Notes

Design loads are stated in this paper are depending on following conditions:

- brace angle: $45^\circ \pm 15^\circ$ – See Annex B
- structural attachments – see Annex B

MQS System

Seismic Designed Solutions

Hilti strongly advises consulting a Structural Engineer to verify that the design and products comply with applicable regulations and standards. The published data is a typical application the suitability for a specific project, design, or jobsite must be assessed by the Engineer of Record for the project. All product's must be strictly used according to the manufacturer's instructions for use and within the application limits as published. The relevant application limits may not be exceeded at any time. All rights reserved by Hilti AG. Duplication, utilization and disclosure of drawings are not permitted unless expressly agreed by Hilti AG.

TRAPEZE WITH WIRE BRACING

Transversal bracing; Support type: R-TPSW-T

Max. design load (seismic horizontal) in [N]	
Longitudinal [Y]	Transversal [X]
Calculation with PROFIS is needed	

Seismic load orientation

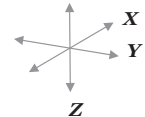

Clip MW-C

Please refer to catalog pages for product information

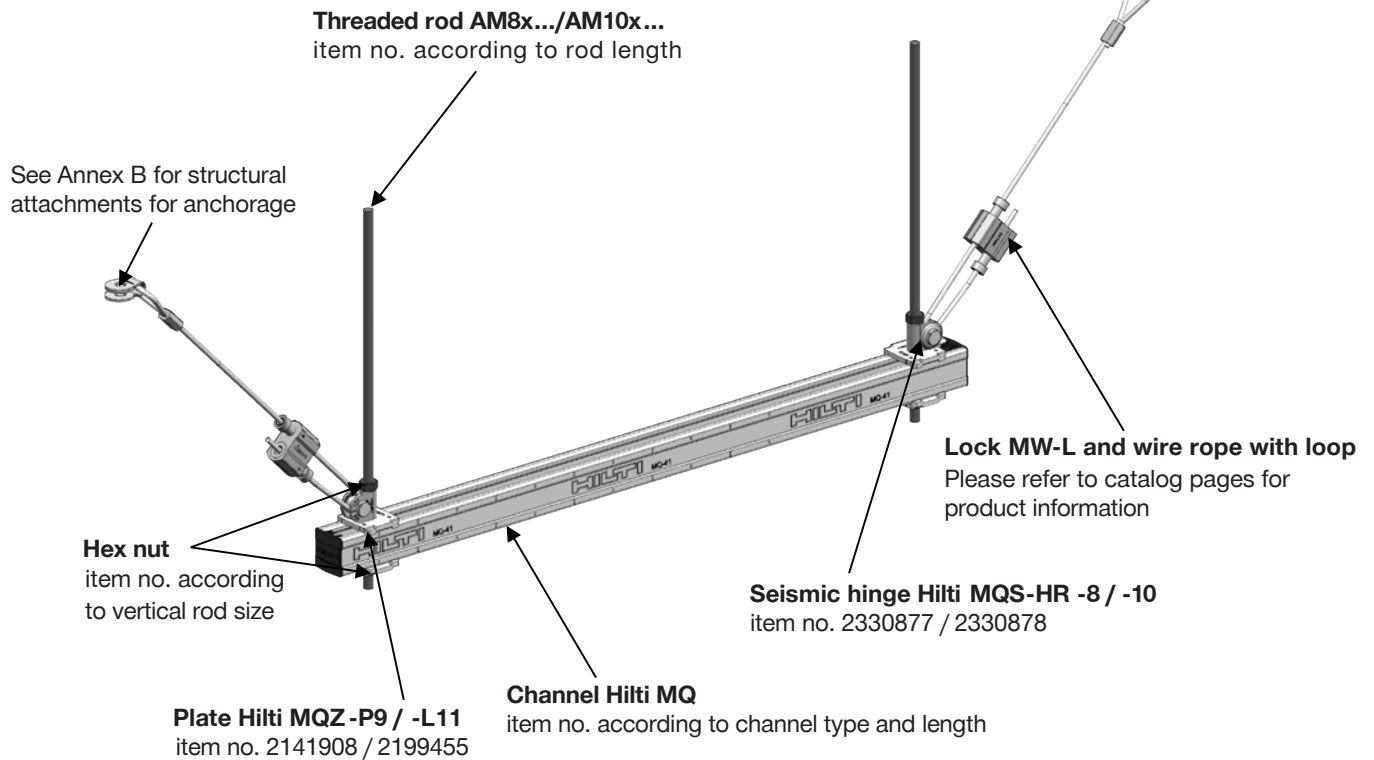

General Design Notes

Design loads are stated in this paper are depending on following conditions:

- brace angle: $45^\circ \pm 15^\circ$ – See Annex B
- structural attachments – see Annex B



MQS System

Seismic Designed Solutions

Iti strongly advises consulting a Structural Engineer to verify that the design and products comply with applicable regulations and standards. The published data is a typical application the suitability for a specific project, design, or jobsite must be assessed by the Engineer of Record for the project. All product's must be strictly used according to the manufacturer's instructions for use and within the application limits as published. The relevant application limits may not be exceeded at any time. All rights reserved by Hilti AG. Duplication, utilization and disclosure of drawings are not permitted unless expressly agreed by Hilti AG.

TRAPEZE WITH ROD BRACING

Transversal multilevel bracing; Support type: R-TPM-T

Max. design load (seismic horizontal) in [N]	
Longitudinal [Y]	Transversal [X]
Calculation with PROFIS is needed	

Seismic load orientation

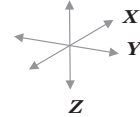

Seismic hinge Hilti MQS-AP -8 / -10 / -12
item no. 2330874 / 2330875 / 2330876

Threaded rod AM8x.../AM10x...
item no. according to rod length

See Annex B for structural
attachments for anchorage

Threaded rod AM10x...
item no. according to rod length

Seismic hinge Hilti MQS-HR -8 / -10
item no. 2330877 / 2330878

Hex nut
item no. according
to vertical rod size

Channel Hilti MQ
item no. according to channel type and length

Plate Hilti MQZ-P9 / -L11
item no. 2141908 / 2199455

General Design Notes

Design loads are stated in this paper are depending on following conditions:

- brace angle: $45^\circ \pm 15^\circ$ – See Annex B
- structural attachments – see Annex B



MQS System

Seismic Designed Solutions

Hilti strongly advises consulting a Structural Engineer to verify that the design and products comply with applicable regulations and standards. The published data is a typical application the suitability for a specific project, design, or jobsite must be assessed by the Engineer of Record for the project. All product's must be strictly used according to the manufacturer's instructions for use and within the application limits as published. The relevant application limits may not be exceeded at any time. All rights reserved by Hilti AG. Duplication, utilization and disclosure of drawings are not permitted unless expressly agreed by Hilti AG.

TRAPEZE WITH ROD BRACING

Longitudinal bracing; Support type: R-TPS-L

Max. design load (seismic horizontal) in [N]	
Longitudinal [Y]	Transversal [X]
Calculation with PROFIS is needed	

Seismic load orientation

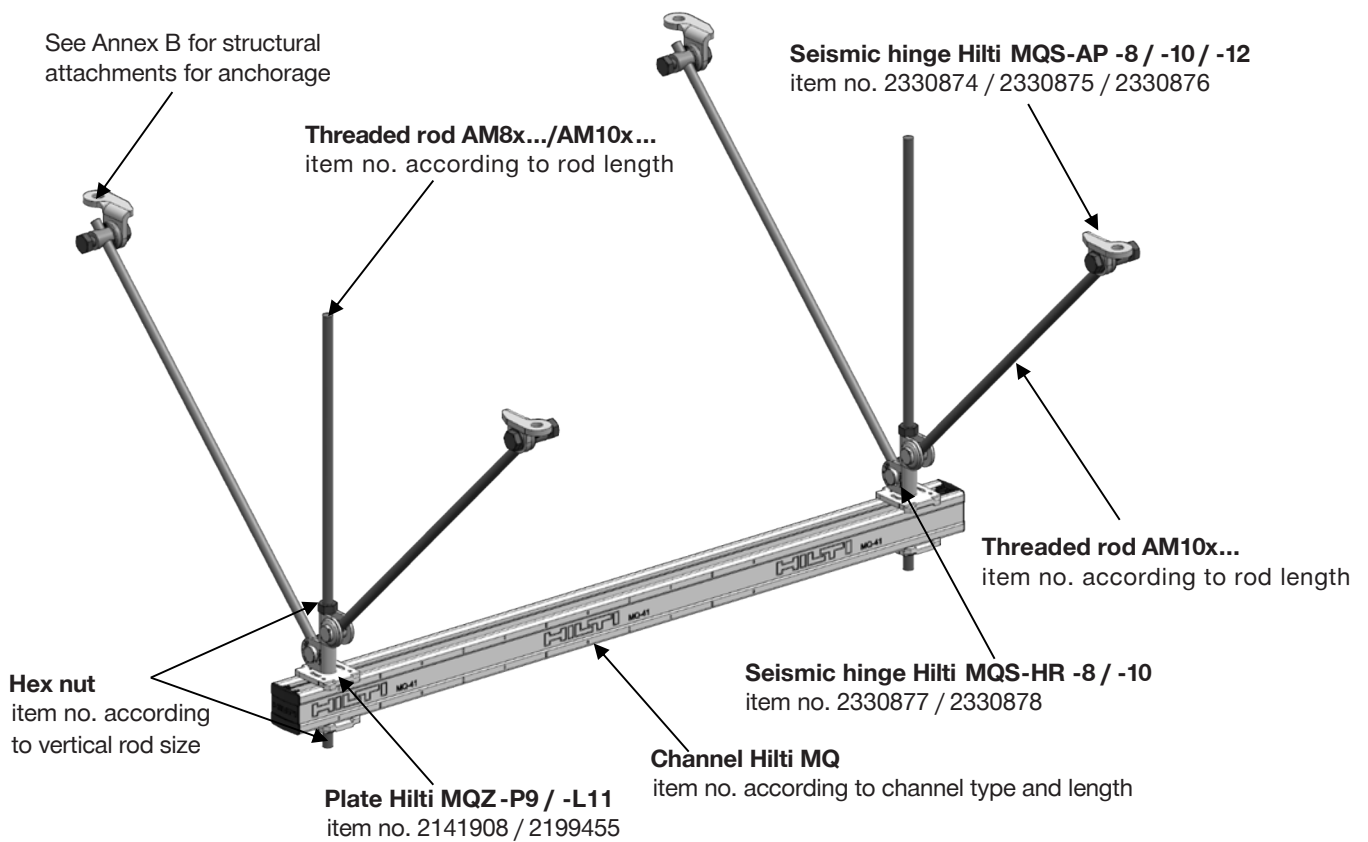
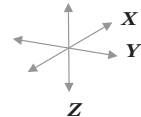

General Design Notes

Design loads are stated in this paper are depending on following conditions:

- brace angle: $45^\circ \pm 15^\circ$ – See Annex B
- structural attachments – see Annex B

MQS System

Seismic Designed Solutions

Iti strongly advises consulting a Structural Engineer to verify that the design and products comply with applicable regulations and standards. The published data is a typical application the suitability for a specific project, design, or jobsite must be assessed by the Engineer of Record for the project. All product's must be strictly used according to the manufacturer's instructions for use and within the application limits as published. The relevant application limits may not be exceeded at any time. All rights reserved by Hilti AG. Duplication, utilization and disclosure of drawings are not permitted unless expressly agreed by Hilti AG.

TRAPEZE WITH ROD BRACING

Longitudinal multilevel bracing; Support type: R-TPM-L

Max. design load (seismic horizontal) in [N]	
Longitudinal [Y]	Transversal [X]
Calculation with PROFIS is needed	

Seismic load orientation

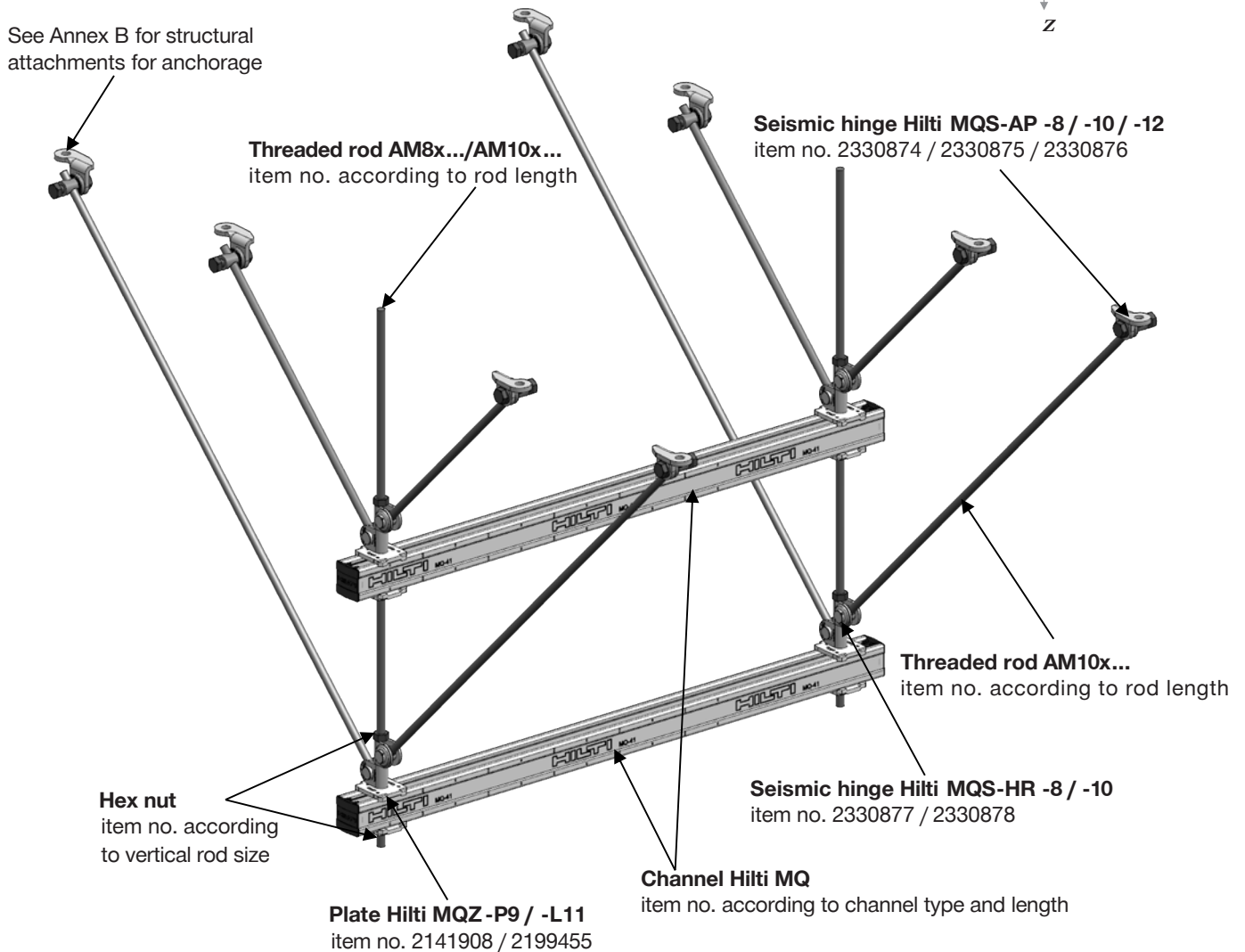
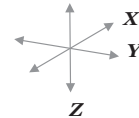

General Design Notes

Design loads are stated in this paper are depending on following conditions:

- brace angle: $45^\circ \pm 15^\circ$ – See Annex B
- structural attachments – see Annex B



MQS System

Seismic Designed Solutions

Hilti strongly advises consulting a Structural Engineer to verify that the design and products comply with applicable regulations and standards. The published data is a typical application the suitability for a specific project, design, or jobsite must be assessed by the Engineer of Record for the project. All product's must be strictly used according to the manufacturer's instructions for use and within the application limits as published. The relevant application limits may not be exceeded at any time. All rights reserved by Hilti AG. Duplication, utilization and disclosure of drawings are not permitted unless expressly agreed by Hilti AG.

TRAPEZE WITH ROD BRACING

4-way bracing; Support type: R-TPS-4W

Max. design load (seismic horizontal) in [N]	
Longitudinal [Y]	Transversal [X]
Calculation with PROFIS is needed	

Seismic load orientation

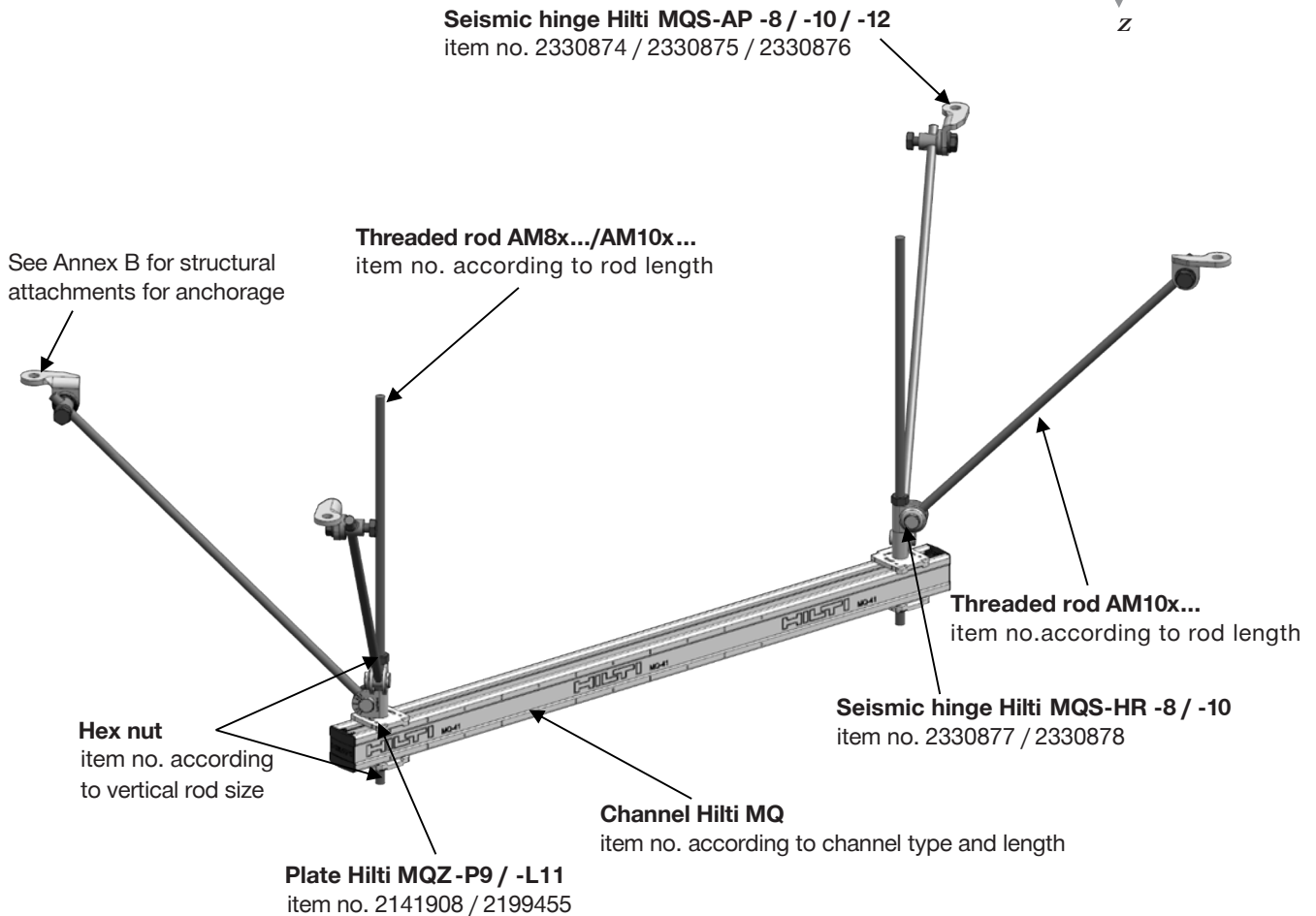
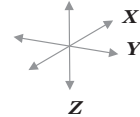

General Design Notes

Design loads are stated in this paper are depending on following conditions:

- brace angle: $45^\circ \pm 15^\circ$ – See Annex B
- structural attachments – see Annex B

MQS System

Seismic Designed Solutions

Iti strongly advises consulting a Structural Engineer to verify that the design and products comply with applicable regulations and standards. The published data is a typical application the suitability for a specific project, design, or jobsite must be assessed by the Engineer of Record for the project. All product's must be strictly used according to the manufacturer's instructions for use and within the application limits as published. The relevant application limits may not be exceeded at any time. All rights reserved by Hilti AG. Duplication, utilization and disclosure of drawings are not permitted unless expressly agreed by Hilti AG.

TRAPEZE WITH ROD BRACING

4-way bracing multilevel ; Support type: R-TPM-4W

Max. design load (seismic horizontal) in [N]	
Longitudinal [Y]	Transversal [X]
Calculation with PROFIS is needed	

Seismic load orientation

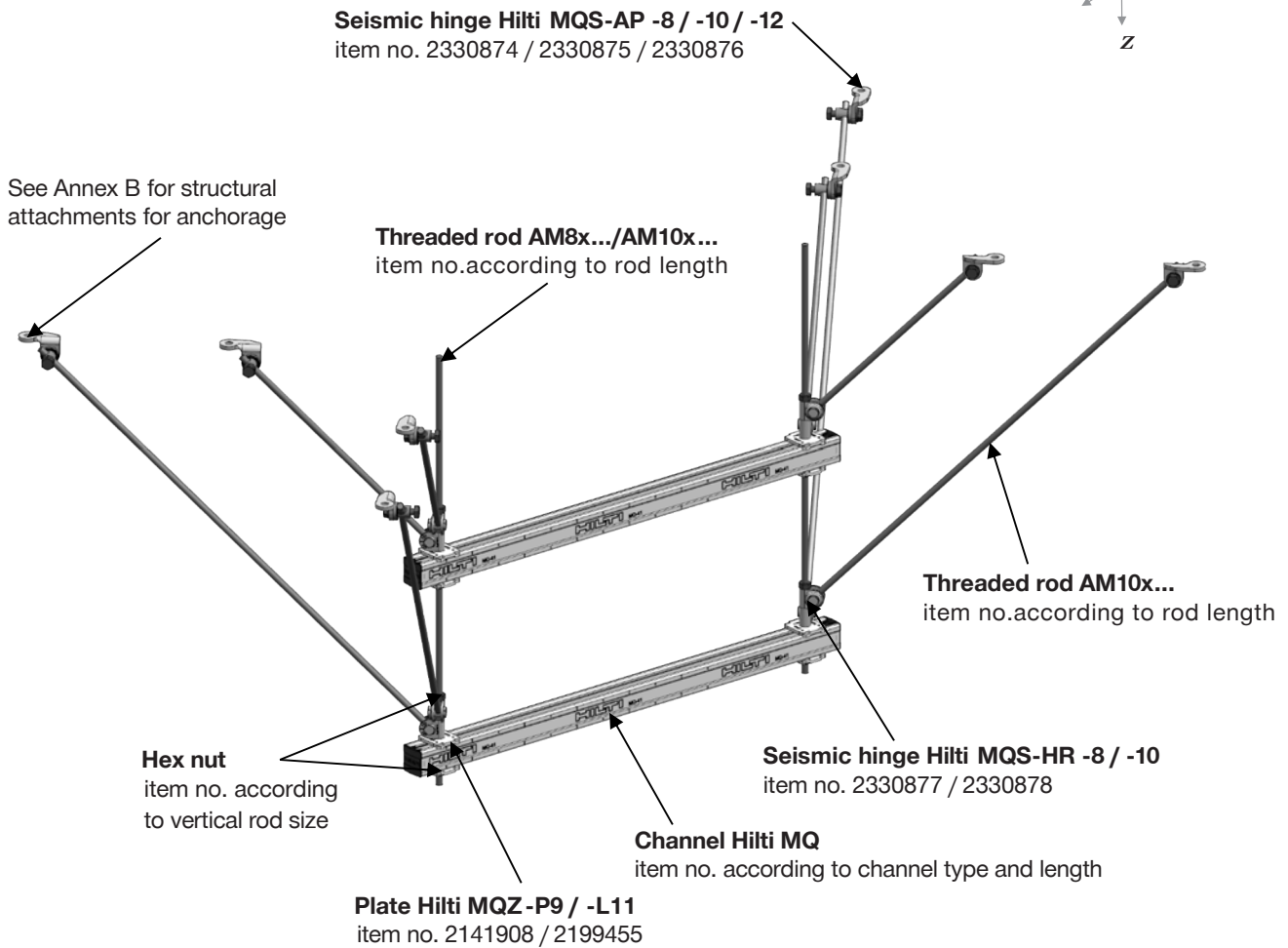
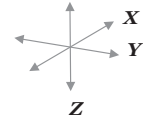

General Design Notes

Design loads are stated in this paper are depending on following conditions:

- brace angle: $45^\circ \pm 15^\circ$ – See Annex B
- structural attachments – see Annex B



MQS System

Seismic Designed Solutions

Hilti strongly advises consulting a Structural Engineer to verify that the design and products comply with applicable regulations and standards. The published data is a typical application the suitability for a specific project, design, or jobsite must be assessed by the Engineer of Record for the project. All product's must be strictly used according to the manufacturer's instructions for use and within the application limits as published. The relevant application limits may not be exceeded at any time. All rights reserved by Hilti AG. Duplication, utilization and disclosure of drawings are not permitted unless expressly agreed by Hilti AG.

TRAPEZE WITH ROD BRACING

Longitudinal bracing; Support type: CR-TPS-L

Max. design load (seismic horizontal) in [N]	
Longitudinal [Y]	Transversal [X]
Calculation with PROFIS is needed	

Seismic load orientation

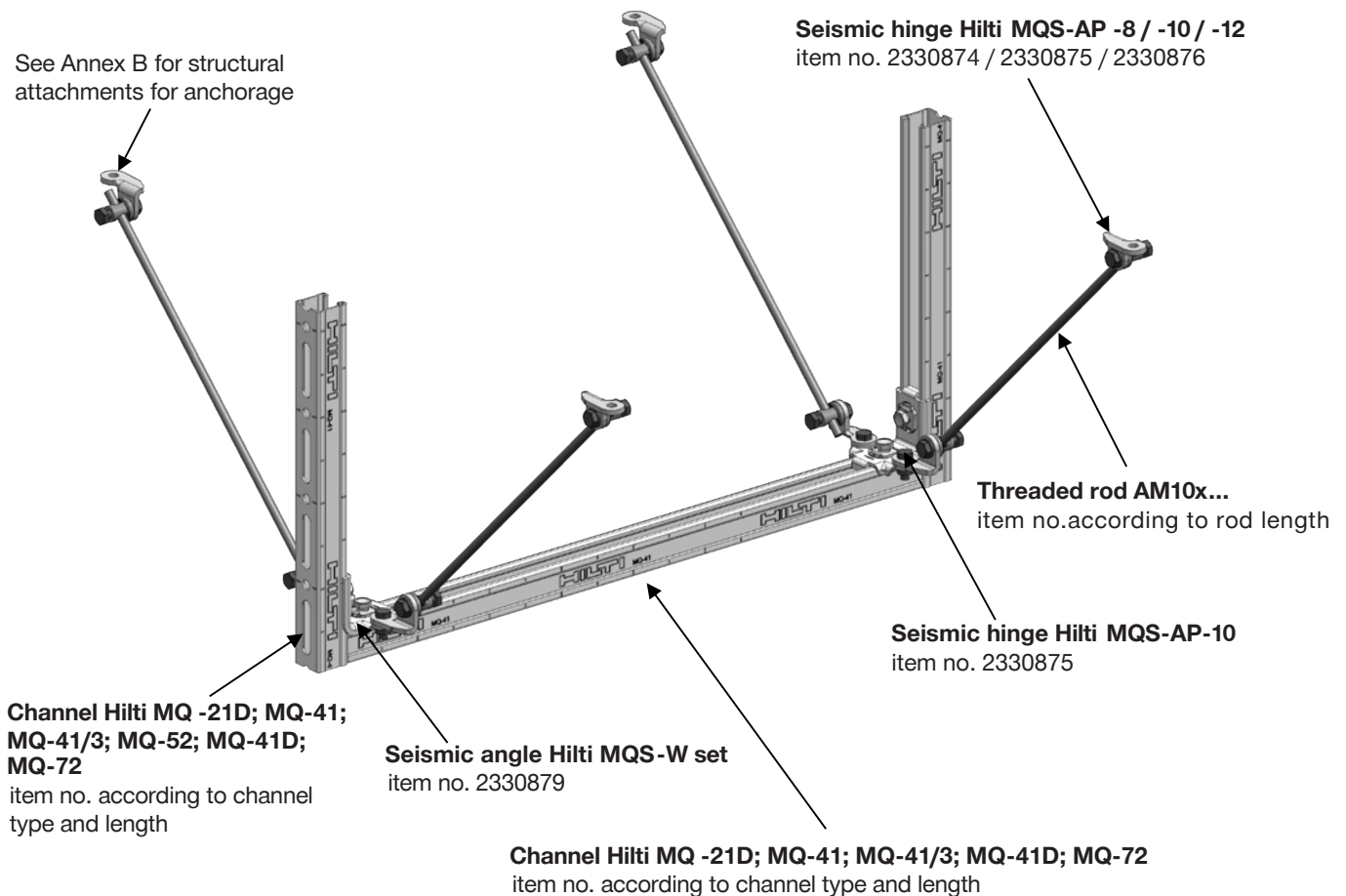
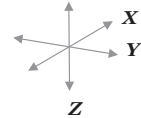

General Design Notes

Design loads are stated in this paper are depending on following conditions:

- brace angle: $45^\circ \pm 15^\circ$ – See Annex B
- structural attachments – see Annex B

MQS System

Seismic Designed Solutions

Iti strongly advises consulting a Structural Engineer to verify that the design and products comply with applicable regulations and standards. The published data is a typical application the suitability for a specific project, design, or jobsite must be assessed by the Engineer of Record for the project. All product's must be strictly used according to the manufacturer's instructions for use and within the application limits as published. The relevant application limits may not be exceeded at any time. All rights reserved by Hilti AG. Duplication, utilization and disclosure of drawings are not permitted unless expressly agreed by Hilti AG.

TRAPEZE WITH ROD BRACING

Transversal bracing; Support type: CR-TPS-T

Max. design load (seismic horizontal) in [N]	
Longitudinal [Y]	Transversal [X]
Calculation with PROFIS is needed	

Seismic load orientation

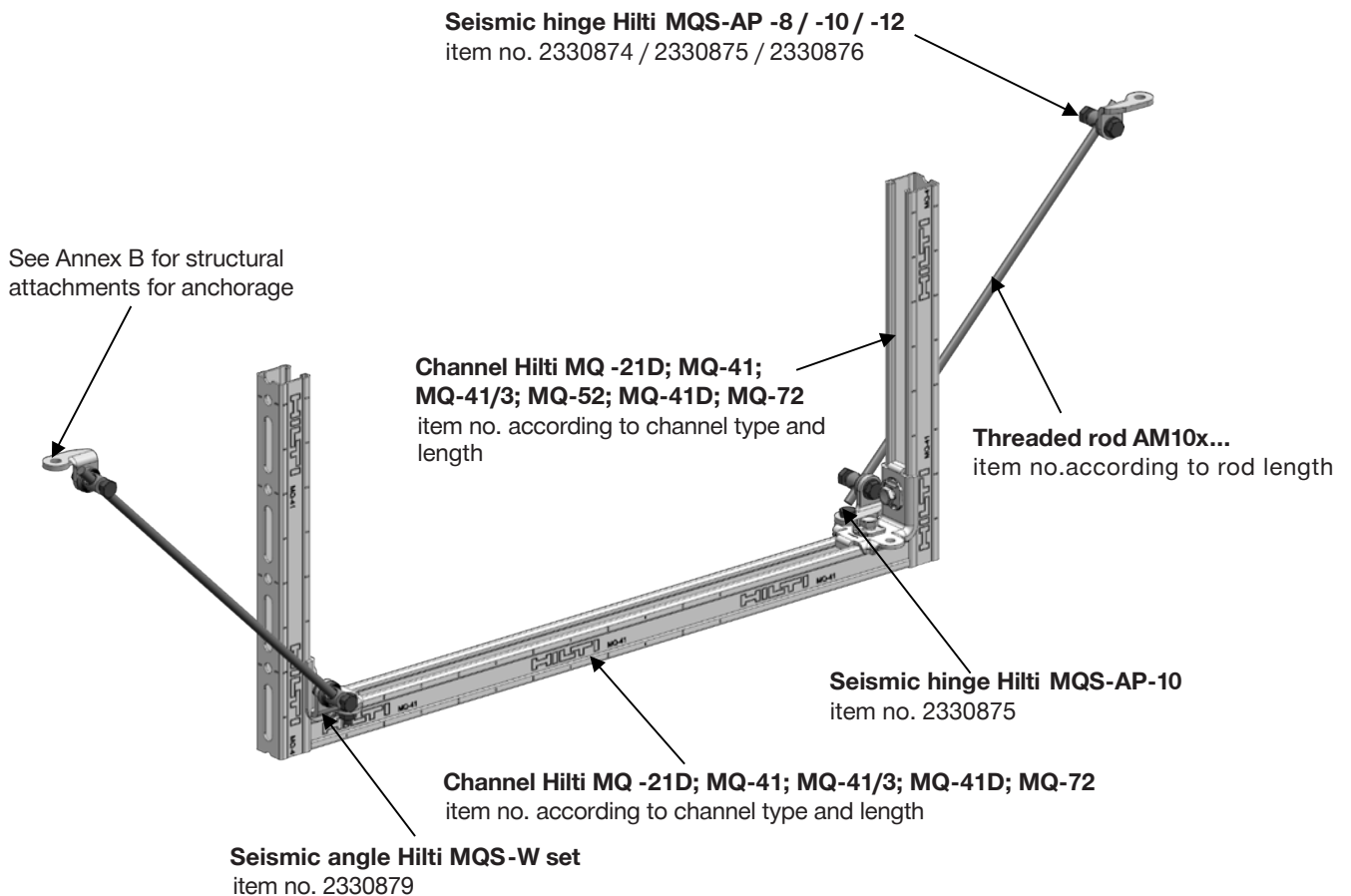
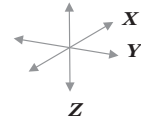

General Design Notes

Design loads are stated in this paper are depending on following conditions:

- brace angle: $45^\circ \pm 15^\circ$ – See Annex B
- structural attachments – see Annex B



MQS System

Seismic Designed Solutions

Hilti strongly advises consulting a Structural Engineer to verify that the design and products comply with applicable regulations and standards. The published data is a typical application the suitability for a specific project, design, or jobsite must be assessed by the Engineer of Record for the project. All product's must be strictly used according to the manufacturer's instructions for use and within the application limits as published. The relevant application limits may not be exceeded at any time. All rights reserved by Hilti AG. Duplication, utilization and disclosure of drawings are not permitted unless expressly agreed by Hilti AG.

TRAPEZE WITH WIRE BRACING

4-way bracing; Support type: CR-TPSW-4W

Max. design load (seismic horizontal) in [N]	
Longitudinal [Y]	Transversal [X]
Calculation with PROFIS is needed	

Seismic load orientation

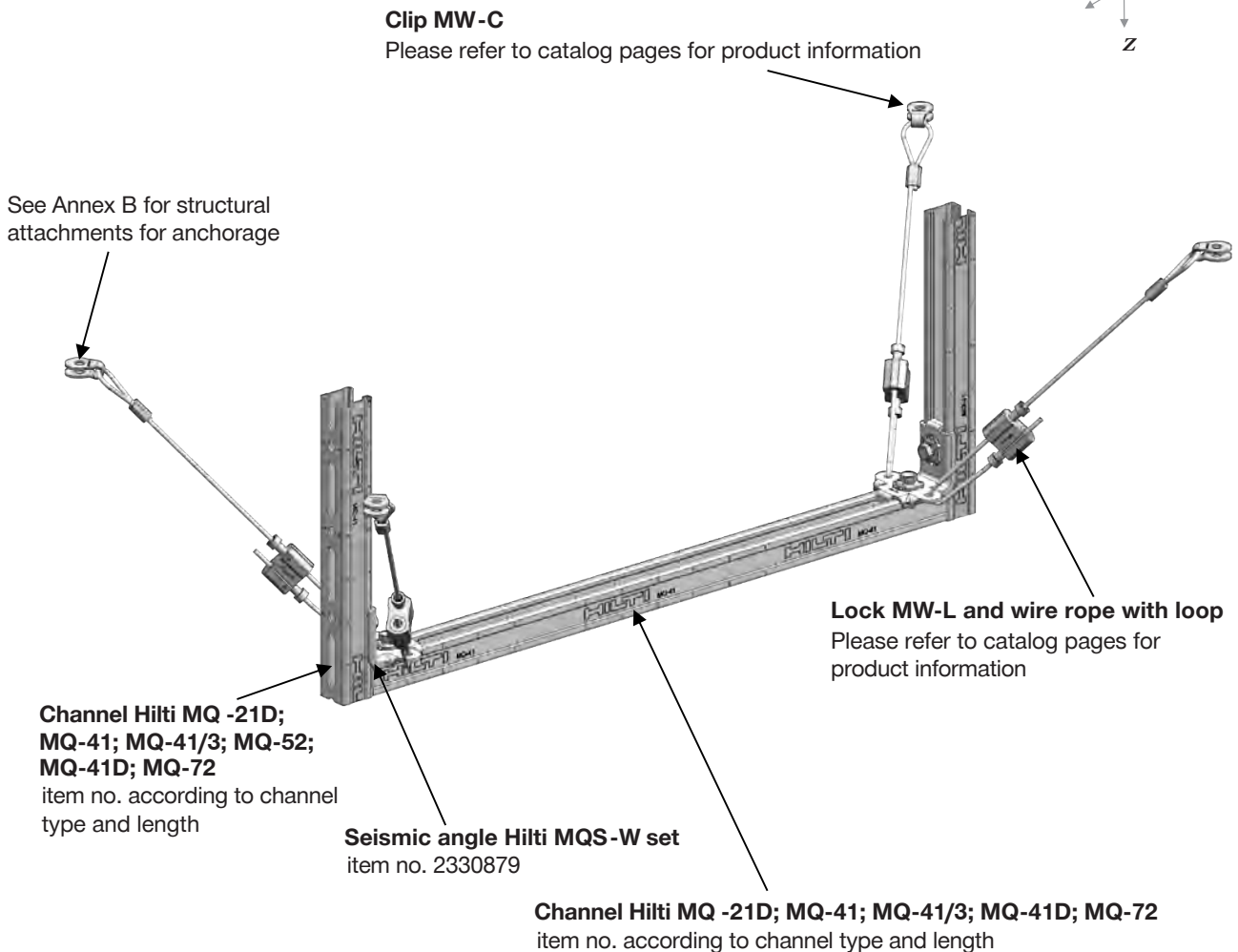
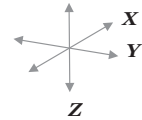

General Design Notes

Design loads are stated in this paper are depending on following conditions:

- brace angle: $45^\circ \pm 15^\circ$ – See Annex B
- structural attachments – see Annex B

MQS System

Seismic Designed Solutions

Iti strongly advises consulting a Structural Engineer to verify that the design and products comply with applicable regulations and standards. The published data is a typical application the suitability for a specific project, design, or jobsite must be assessed by the Engineer of Record for the project. All product's must be strictly used according to the manufacturer's instructions for use and within the application limits as published. The relevant application limits may not be exceeded at any time. All rights reserved by Hilti AG. Duplication, utilization and disclosure of drawings are not permitted unless expressly agreed by Hilti AG.

TRAPEZE WITH CHANNEL BRACING

Longitudinal bracing; Support type: C-TPS-L

Max. design load (seismic horizontal) in [N]	
Longitudinal [Y]	Transversal [X]
Calculation with PROFIS is needed	

Seismic load orientation

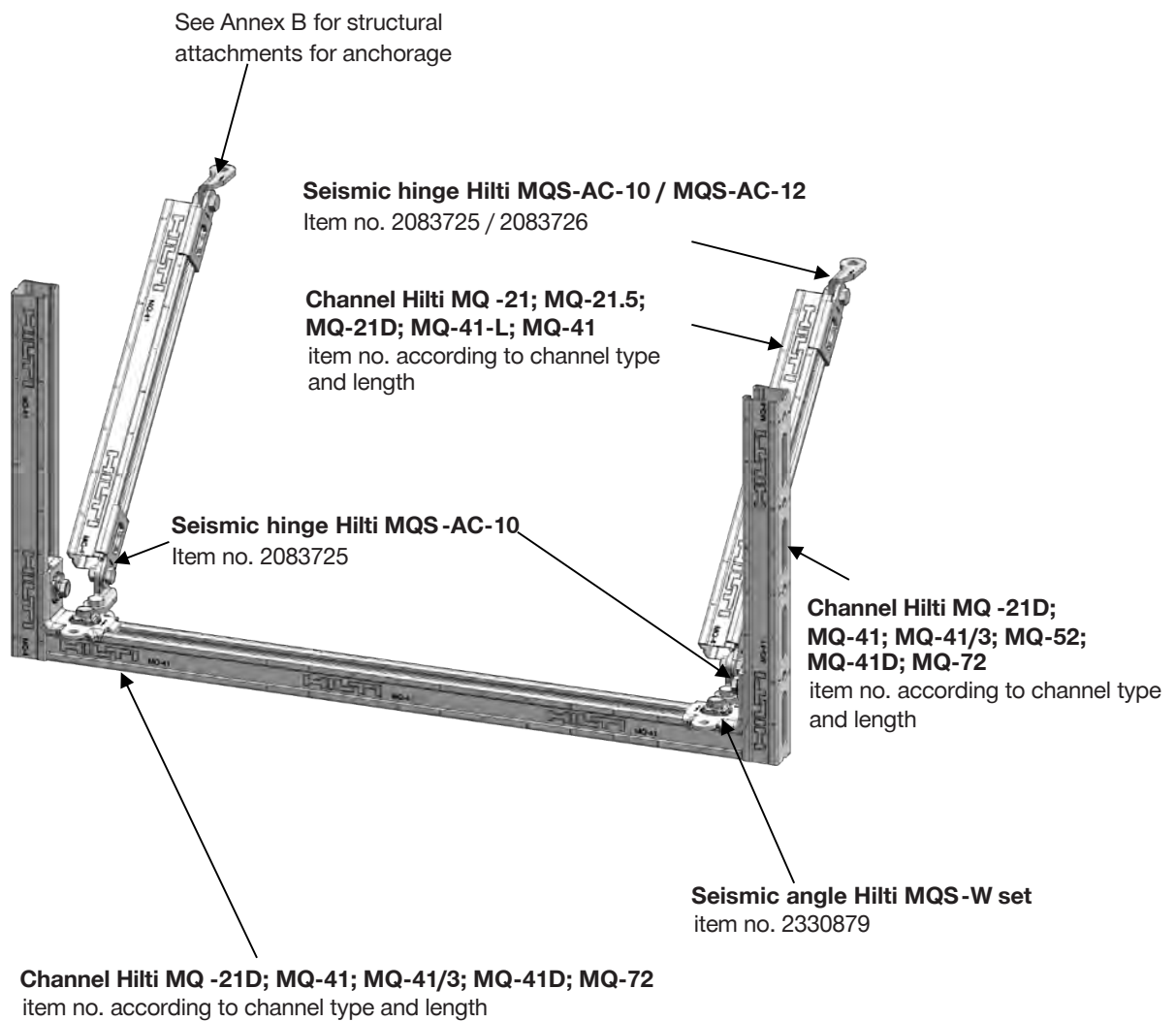
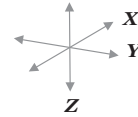

General Design Notes

Design loads are stated in this paper are depending on following conditions:

- brace angle: $45^\circ \pm 15^\circ$ – See Annex B
- structural attachments – see Annex B

MQS System

Seismic Designed Solutions

Hilti strongly advises consulting a Structural Engineer to verify that the design and products comply with applicable regulations and standards. The published data is a typical application the suitability for a specific project, design, or jobsite must be assessed by the Engineer of Record for the project. All product's must be strictly used according to the manufacturer's instructions for use and within the application limits as published. The relevant application limits may not be exceeded at any time. All rights reserved by Hilti AG. Duplication, utilization and disclosure of drawings are not permitted unless expressly agreed by Hilti AG.

TRAPEZE WITH CHANNEL BRACING

Longitudinal bracing multilevel ; Support type: C-TPM-L

Max. design load (seismic horizontal) in [N]	
Longitudinal [Y]	Transversal [X]
Calculation with PROFIS is needed	

Seismic load orientation

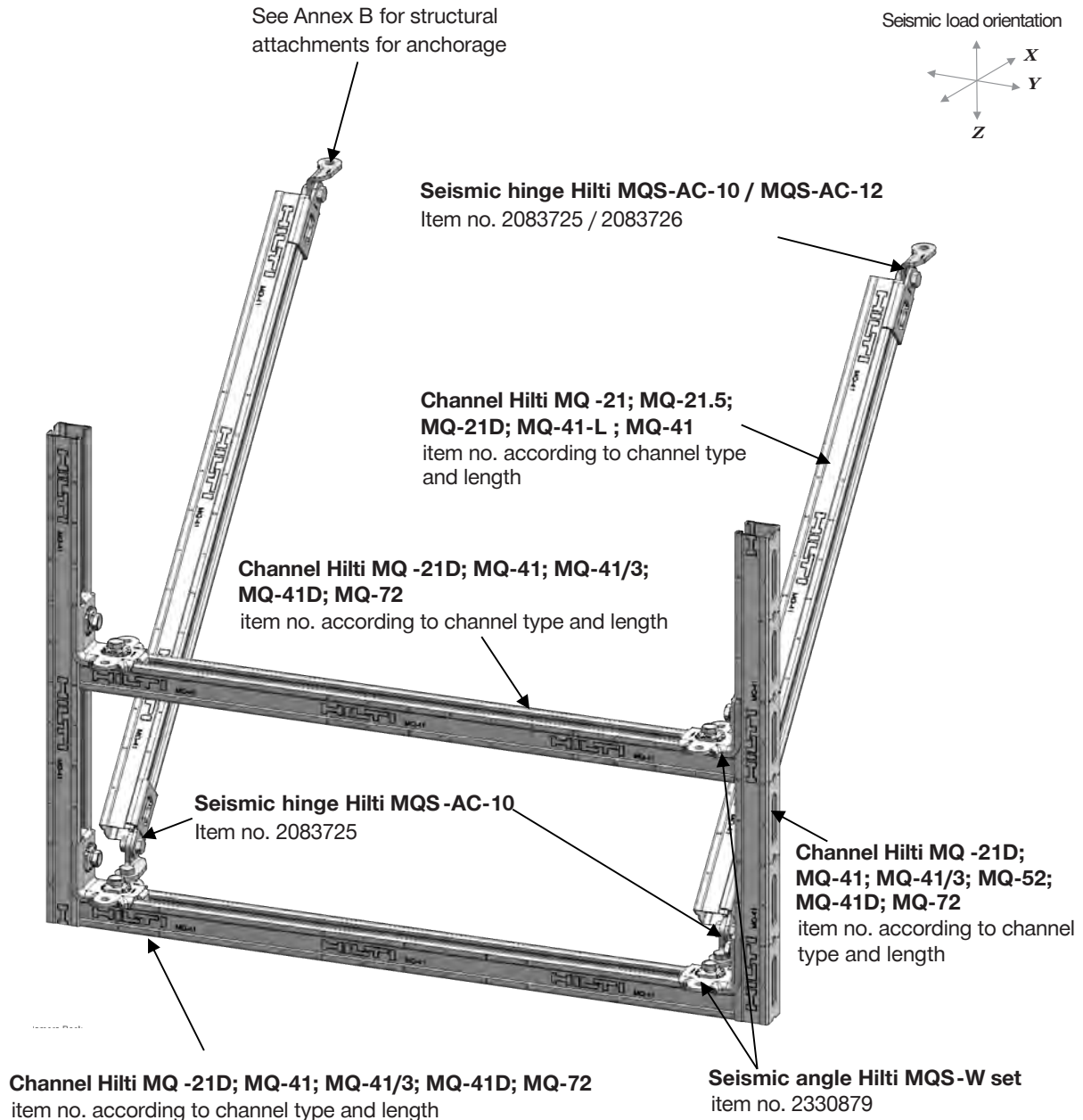
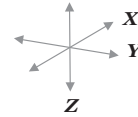

General Design Notes

Design loads are stated in this paper are depending on following conditions:

- brace angle: $45^\circ \pm 15^\circ$ – See Annex B
- structural attachments – see Annex B

MQS System

Seismic Designed Solutions

Iti strongly advises consulting a Structural Engineer to verify that the design and products comply with applicable regulations and standards. The published data is a typical application the suitability for a specific project, design, or jobsite must be assessed by the Engineer of Record for the project. All product's must be strictly used according to the manufacturer's instructions for use and within the application limits as published. The relevant application limits may not be exceeded at any time. All rights reserved by Hilti AG. Duplication, utilization and disclosure of drawings are not permitted unless expressly agreed by Hilti AG.

TRAPEZE WITH CHANNEL BRACING

Transversal bracing; Support type: C-TPS-T

Max. design load (seismic horizontal) in [N]	
Longitudinal [Y]	Transversal [X]
Calculation with PROFIS is needed	

Seismic load orientation

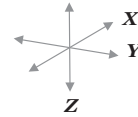

See Annex B for structural attachments for anchorage

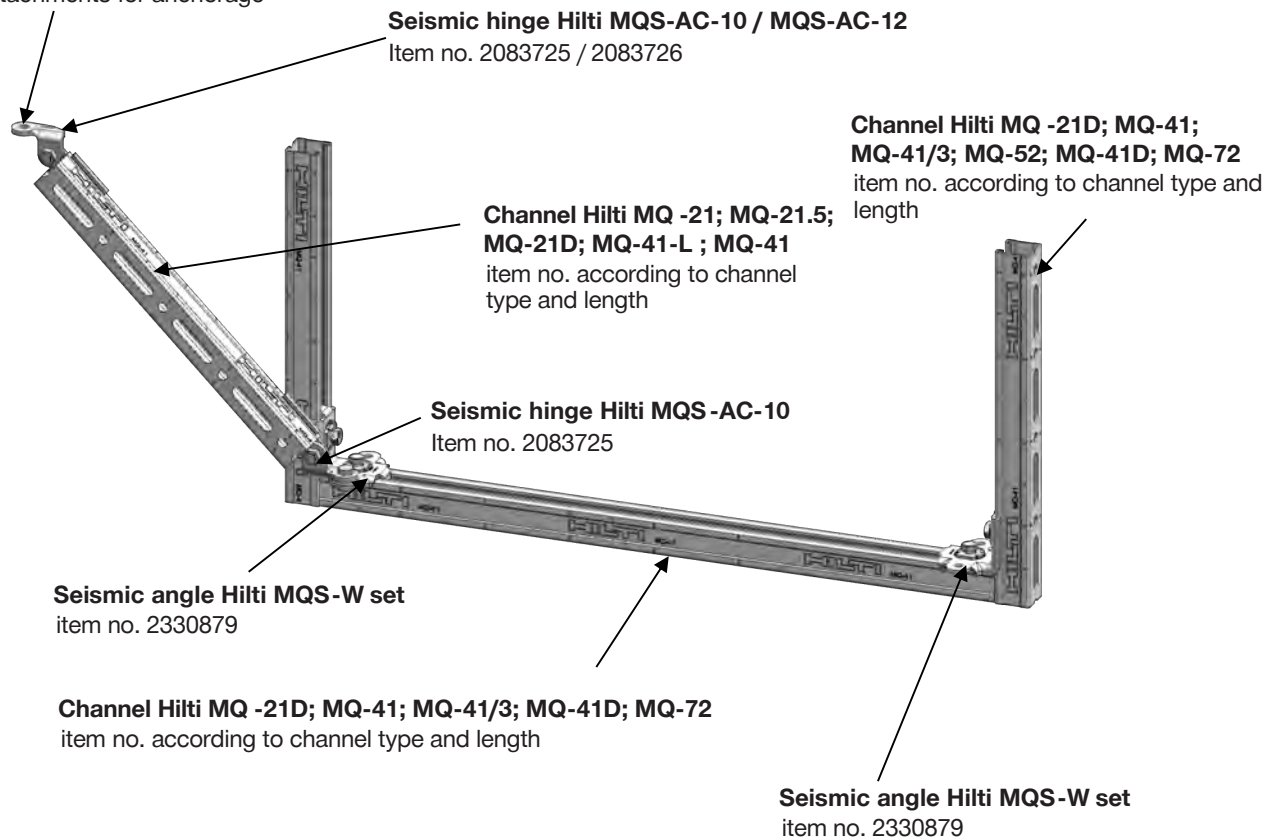

General Design Notes

Design loads are stated in this paper are depending on following conditions:

- brace angle: $45^\circ \pm 15^\circ$ – See Annex B
- structural attachments – see Annex B



MQS System

Seismic Designed Solutions

Hilti strongly advises consulting a Structural Engineer to verify that the design and products comply with applicable regulations and standards. The published data is a typical application the suitability for a specific project, design, or jobsite must be assessed by the Engineer of Record for the project. All product's must be strictly used according to the manufacturer's instructions for use and within the application limits as published. The relevant application limits may not be exceeded at any time. All rights reserved by Hilti AG. Duplication, utilization and disclosure of drawings are not permitted unless expressly agreed by Hilti AG.

TRAPEZE WITH CHANNEL BRACING

Transversal bracing multilevel; Support type: C-TPM-T

Max. design load (seismic horizontal) in [N]	
Longitudinal [Y]	Transversal [X]
Calculation with PROFIS is needed	

Seismic load orientation

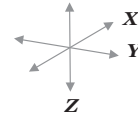

Seismic hinge Hilti MQS-AC-10 / MQS-AC-12

Item no. 2083725 / 2083726

See Annex B for structural attachments for anchorage

Channel Hilti MQ -21D; MQ-41; MQ-41/3; MQ-52; MQ-41D; MQ-72
item no. according to channel type and length

Channel Hilti MQ -21; MQ-21.5; MQ-21D; MQ-41-L; MQ-41
item no. according to channel type and length

Seismic hinge Hilti MQS-AC-10
Item no. 2083725

Channel Hilti MQ -21D; MQ-41; MQ-41/3; MQ-41D; MQ-72
item no. according to channel type and length

Seismic angle Hilti MQS-W set
item no. 2330879

General Design Notes

Design loads are stated in this paper are depending on following conditions:

- brace angle: $45^\circ \pm 15^\circ$ – See Annex B
- structural attachments – see Annex B



MQS System

Seismic Designed Solutions

Iti strongly advises consulting a Structural Engineer to verify that the design and products comply with applicable regulations and standards. The published data is a typical application the suitability for a specific project, design, or jobsite must be assessed by the Engineer of Record for the project. All product's must be strictly used according to the manufacturer's instructions for use and within the application limits as published. The relevant application limits may not be exceeded at any time. All rights reserved by Hilti AG. Duplication, utilization and disclosure of drawings are not permitted unless expressly agreed by Hilti AG.

TRAPEZE WITH CHANNEL BRACING

4-way bracing; Support type: C-TPS-4W

Max. design load (seismic horizontal) in [N]	
Longitudinal [Y]	Transversal [X]
Calculation with PROFIS is needed	

Seismic load orientation

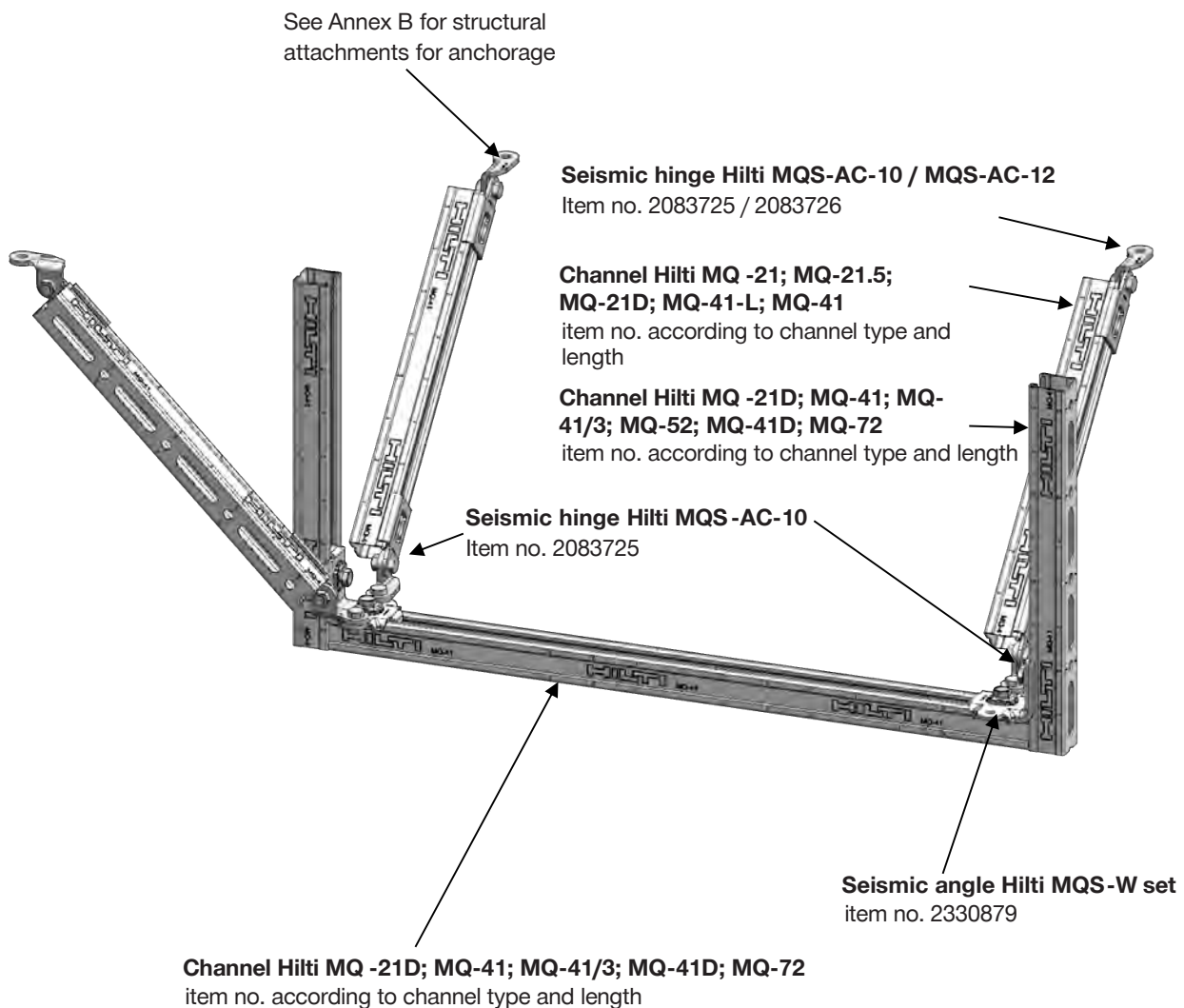
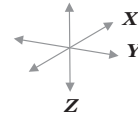

General Design Notes

Design loads are stated in this paper are depending on following conditions:

- brace angle: $45^\circ \pm 15^\circ$ – See Annex B
- structural attachments – see Annex B



MQS System

Seismic Designed Solutions

Hilti strongly advises consulting a Structural Engineer to verify that the design and products comply with applicable regulations and standards. The published data is a typical application the suitability for a specific project, design, or jobsite must be assessed by the Engineer of Record for the project. All product's must be strictly used according to the manufacturer's instructions for use and within the application limits as published. The relevant application limits may not be exceeded at any time. All rights reserved by Hilti AG. Duplication, utilization and disclosure of drawings are not permitted unless expressly agreed by Hilti AG.

TRAPEZE WITH CHANNEL BRACING

4-way bracing multilevel ; Support type: C-TPM-4W

Max. design load (seismic horizontal) in [N]	
Longitudinal [Y]	Transversal [X]
Calculation with PROFIS is needed	

Seismic load orientation

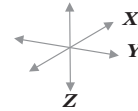

See Annex B for structural attachments for anchorage

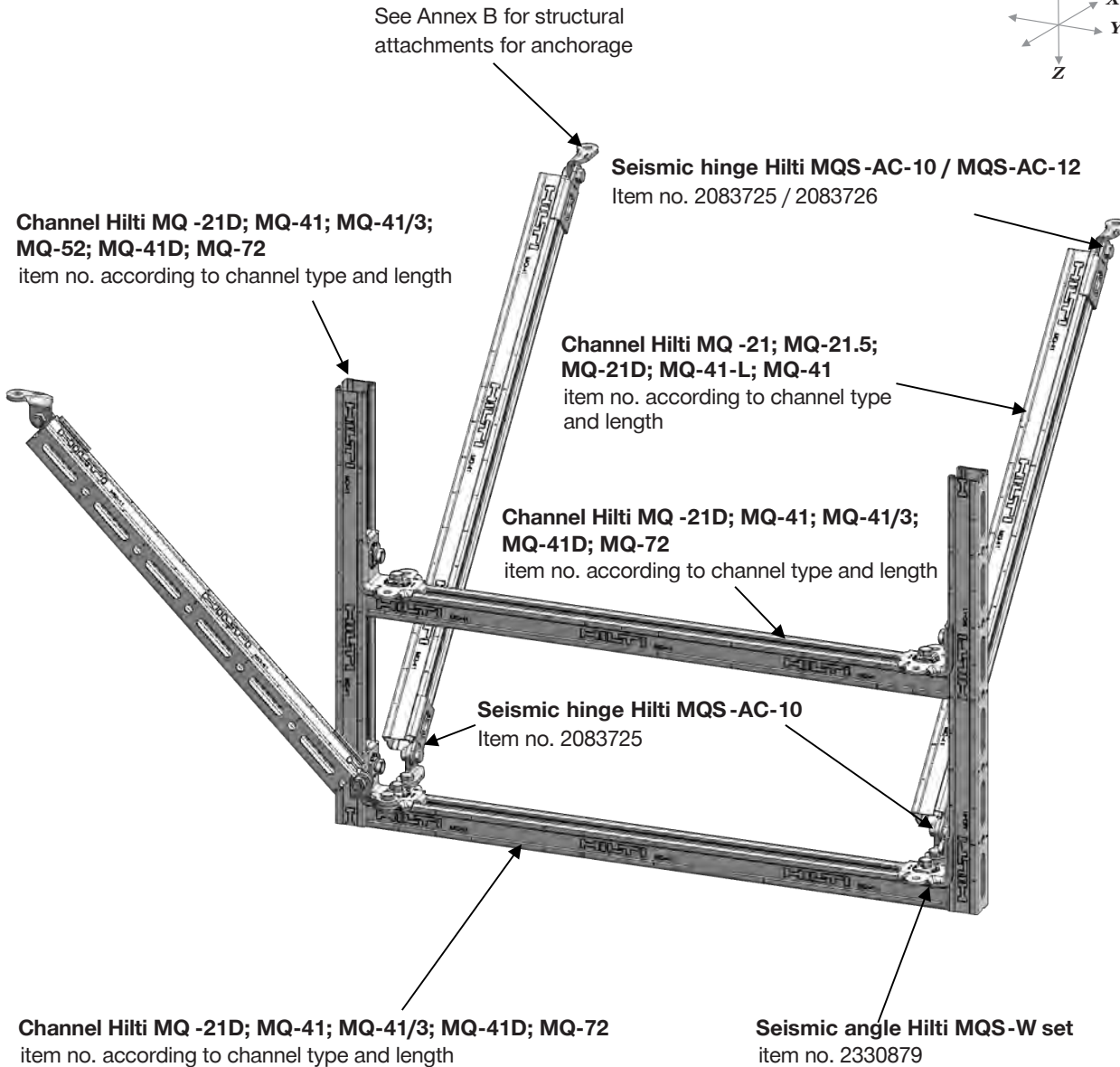

General Design Notes

Design loads are stated in this paper are depending on following conditions:

- brace angle: $45^\circ \pm 15^\circ$ – See Annex B
- structural attachments – see Annex B

MQS System

Seismic Designed Solutions

Iti strongly advises consulting a Structural Engineer to verify that the design and products comply with applicable regulations and standards. The published data is a typical application the suitability for a specific project, design, or jobsite must be assessed by the Engineer of Record for the project. All product's must be strictly used according to the manufacturer's instructions for use and within the application limits as published. The relevant application limits may not be exceeded at any time. All rights reserved by Hilti AG. Duplication, utilization and disclosure of drawings are not permitted unless expressly agreed by Hilti AG.

WALL BRACKET

Support type: S-CT-01

Max. design load (seismic horizontal) in [N]	
Longitudinal [Y]	Transversal [X]
Calculation with PROFIS is needed	

Seismic load orientation

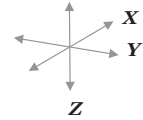

See Annex B for structural attachments for anchorage

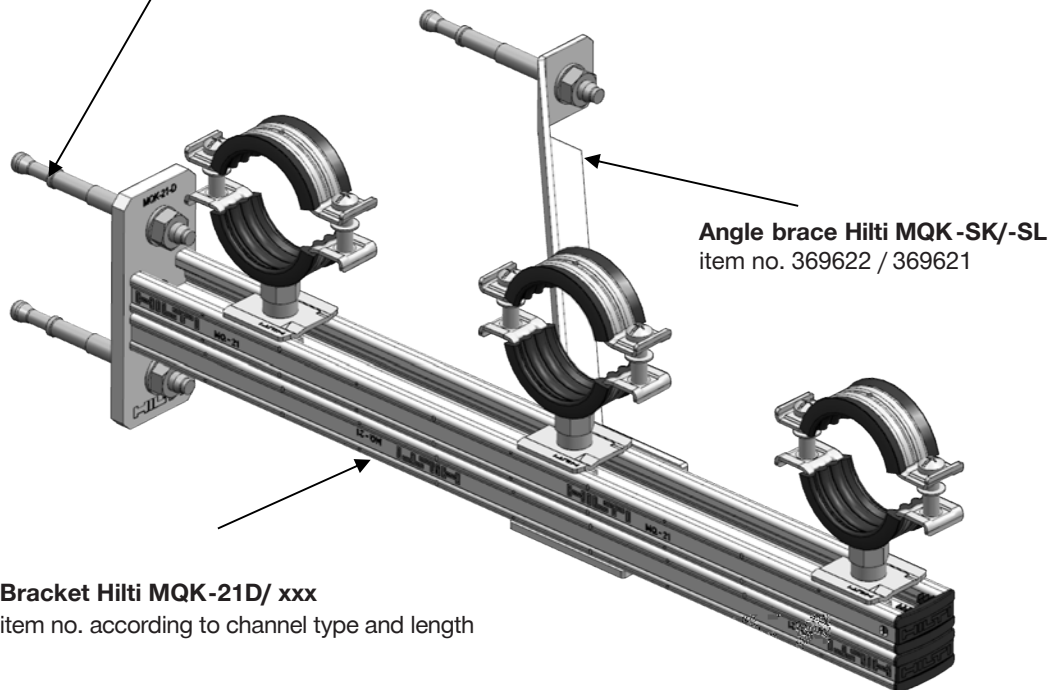

Exp

General Design Notes

Design loads are stated in this paper are depending on following conditions:

- structural attachments – see Annex B



MQS System

Seismic Designed Solutions

Hilti strongly advises consulting a Structural Engineer to verify that the design and products comply with applicable regulations and standards. The published data is a typical application the suitability for a specific project, design, or jobsite must be assessed by the Engineer of Record for the project. All product's must be strictly used according to the manufacturer's instructions for use and within the application limits as published. The relevant application limits may not be exceeded at any time. All rights reserved by Hilti AG. Duplication, utilization and disclosure of drawings are not permitted unless expressly agreed by Hilti AG.

WALL BRACKET

Support type: S-CT-02

Max. design load (seismic horizontal) in [N]	
Longitudinal [Y]	Transversal [X]
Calculation with PROFIS is needed	

Seismic load orientation

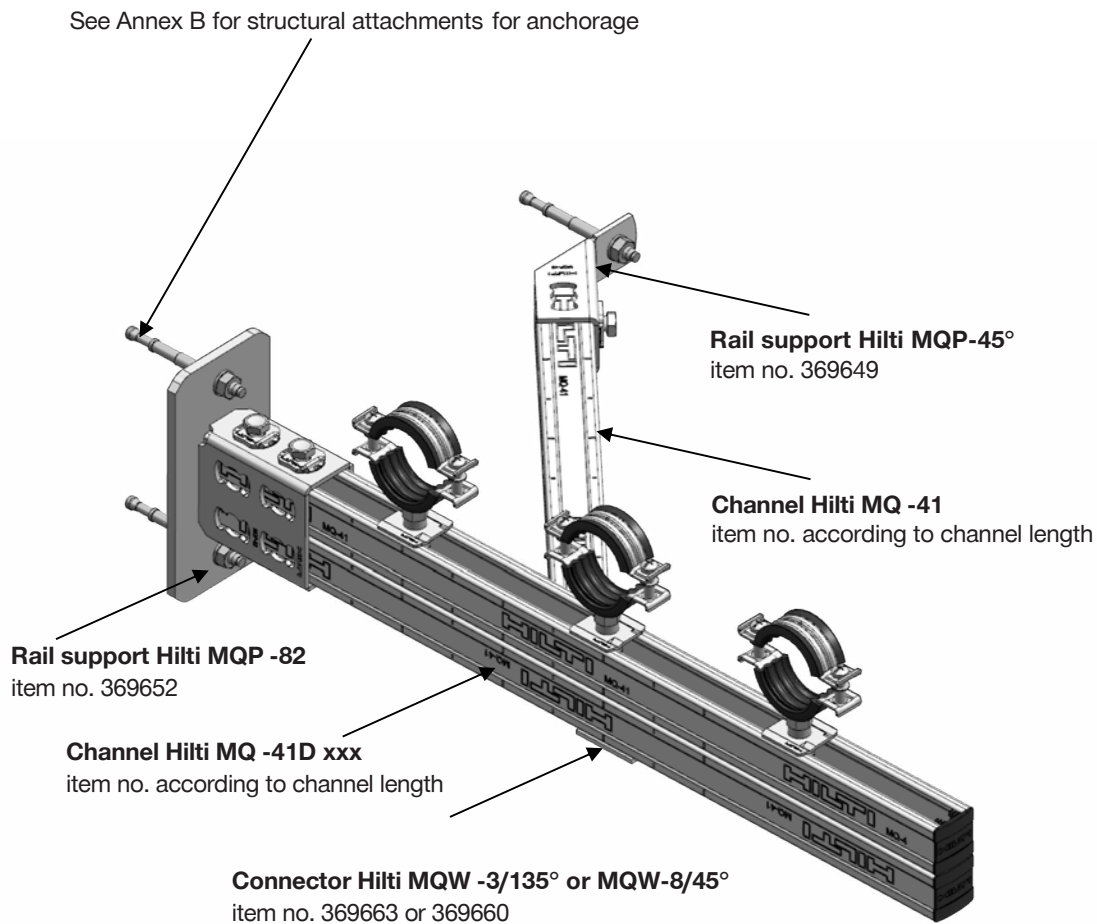
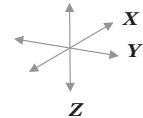

General Design Notes

Design loads are stated in this paper are depending on following conditions:

- structural attachments – see Annex B



MQS System

Seismic Designed Solutions

Iti strongly advises consulting a Structural Engineer to verify that the design and products comply with applicable regulations and standards. The published data is a typical application the suitability for a specific project, design, or jobsite must be assessed by the Engineer of Record for the project. All product's must be strictly used according to the manufacturer's instructions for use and within the application limits as published. The relevant application limits may not be exceeded at any time. All rights reserved by Hilti AG. Duplication, utilization and disclosure of drawings are not permitted unless expressly agreed by Hilti AG.

VENTILATION SYSTEM WITH ROD BRACING

Support type: S-V-01

Max. design load (seismic horizontal) in [N]	
Longitudinal [Y]	Transversal [X]
Calculation with PROFIS is needed	

Seismic load orientation

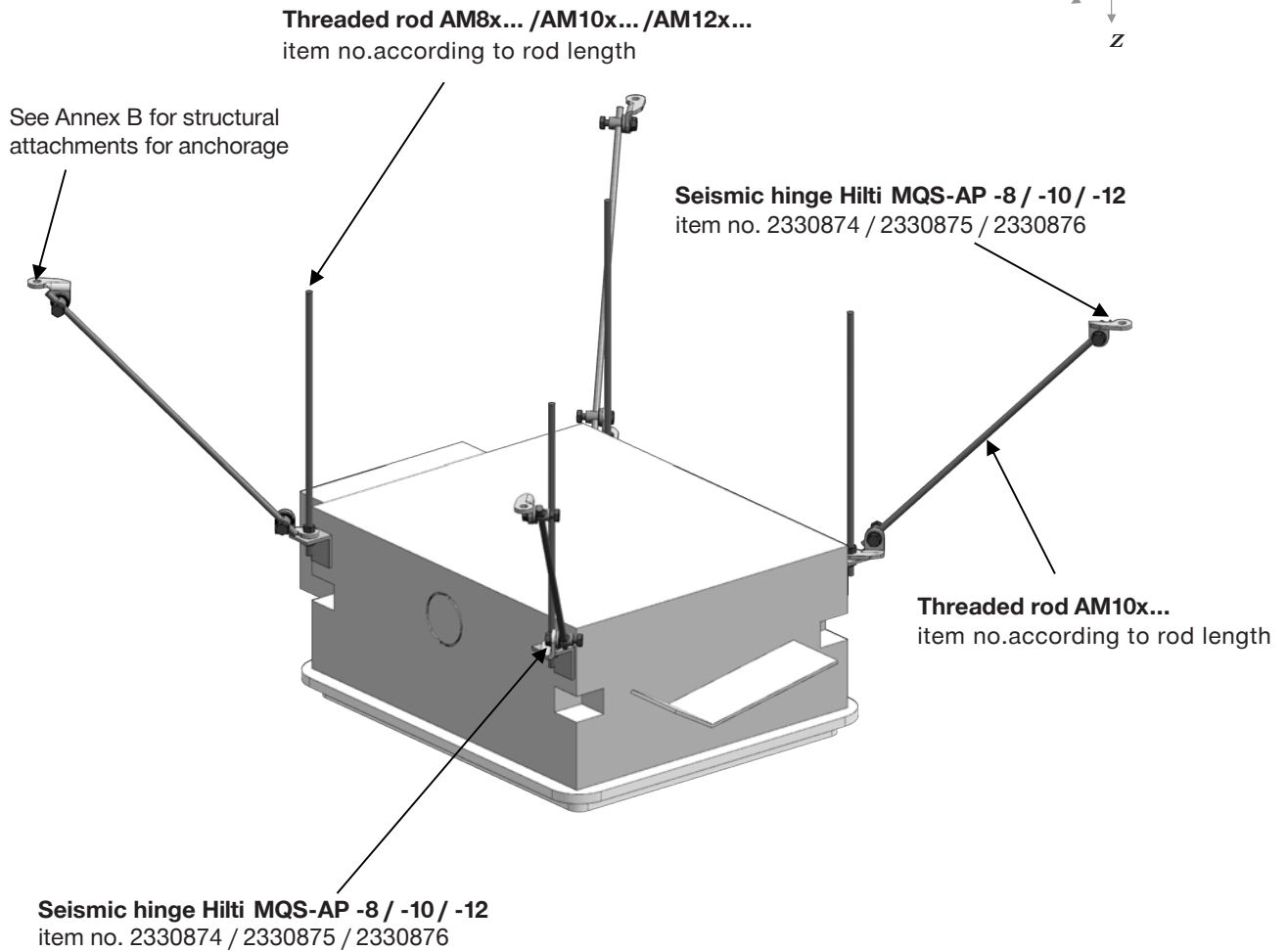
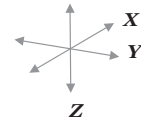

General Design Notes

Design loads are stated in this paper are depending on following conditions:

- brace angle: $45^\circ \pm 15^\circ$ – See Annex B
- structural attachments – see Annex B



MQS System

Seismic Designed Solutions

Hilti strongly advises consulting a Structural Engineer to verify that the design and products comply with applicable regulations and standards. The published data is a typical application the suitability for a specific project, design, or jobsite must be assessed by the Engineer of Record for the project. All product's must be strictly used according to the manufacturer's instructions for use and within the application limits as published. The relevant application limits may not be exceeded at any time. All rights reserved by Hilti AG. Duplication, utilization and disclosure of drawings are not permitted unless expressly agreed by Hilti AG.

ANGLE VARIATION OF BRACING WITH CHANNELS

Longitudinal bracing

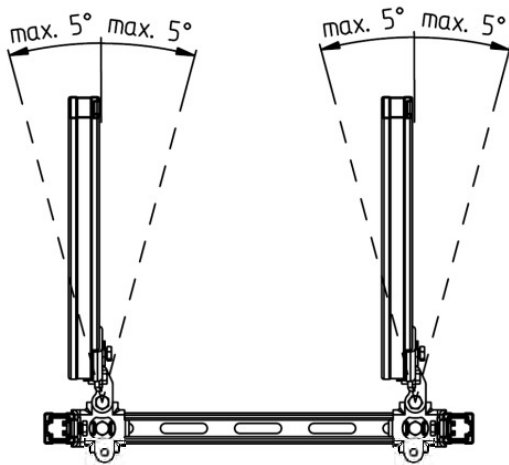

Top view – bracing direction on main axis of the pipe run

Transversal bracing

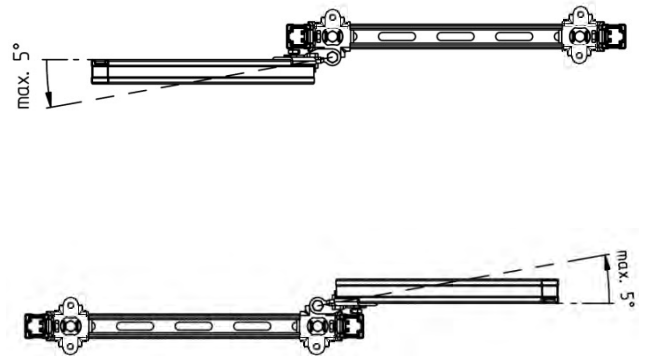

Top view – bracing direction on main axis of the pipe run

4-way bracing

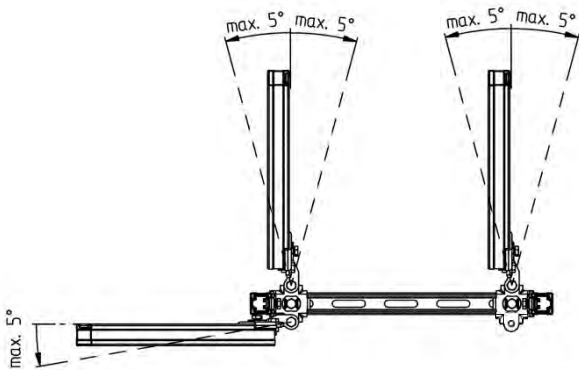

Top view – bracing direction on main axis of the pipe run

Tilt angle – for all bracings

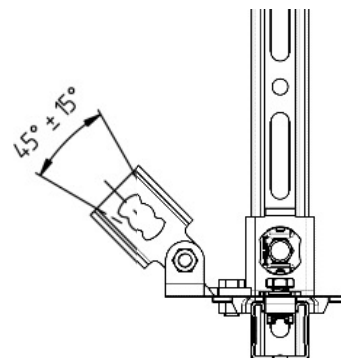

Side view – bracing angle on the horizontal level

ANGLE VARIATION OF BRACING WITH RODS

Longitudinal bracing

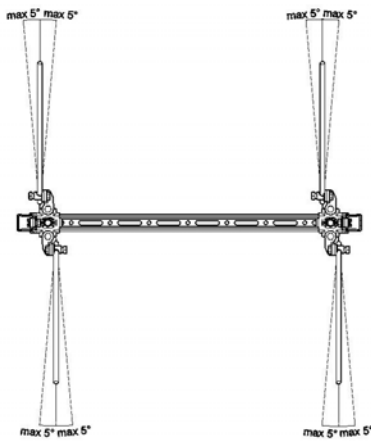

Top view – bracing direction on main axis of the pipe run

Transversal bracing

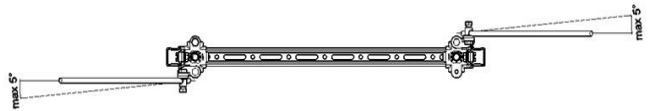

Top view – bracing direction on main axis of the pipe run

4-way bracing

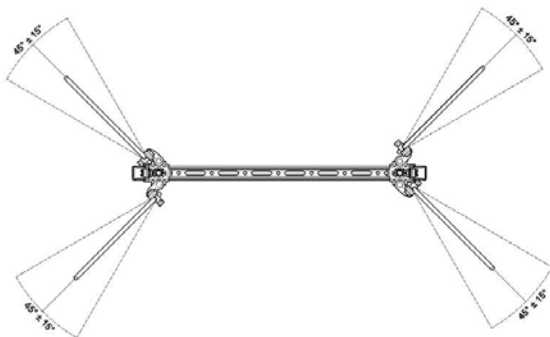

Top view – bracing direction on main axis of the pipe run

Tilt angle – for all bracings

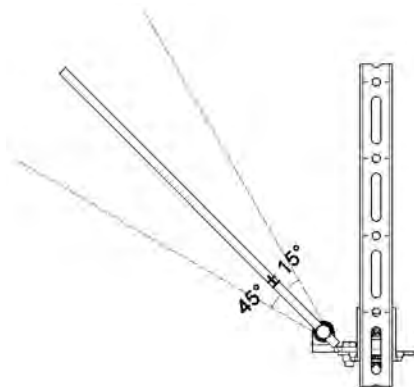

Side view – bracing angle on the horizontal level

STRUCTURAL ATTACHMENT ON SOLID CONCRETE

Fastening of seismic rod bracing

Base material

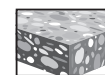

Solid concrete

Seismic hinge MQS-AP

	Stud anchor	Screw anchor
MQS-AP-8 Item no.: 2330874	HST3 M8x75 -/10	
MQS-AP-10 Item no.: 2330875	HST3 M10x90 30/10 Item no.: 2105712	HUS3-H 8x75 25/15/5 Item no.: 2079796
MQS-AP-12 Item no.: 2330876	HST3 M12x115 40/20 Item no.: 2105719	HUS3-H 10x90 35/15/5 Item no.: 2079914



Seismic hinge MQS-CH

	Stud anchor	Screw anchor
MQS-CH Item no.: 2083741	HST3 M10x90 30/10 Item no.: 2105712	HUS3-H 8x75 25/15/5 Item no.: 2079796



Seismic hinge MQS-AC

	Stud anchor	Screw anchor
MQS-AC-10 Item no.: 2083725	HST3 M10x90 30/10 Item no.: 2105712	HUS3-H 8x75 25/15/5 Item no.: 2079796
MQS-AC-12 Item no.: 2083726	HST3 M12x115 40/20 Item no.: 2105719	HUS3-H 10x90 35/15/5 Item no.: 2079914



Ceiling clip MW-C

	Stud anchor	Screw anchor
MW-C Item no.: 2287563	HST3 M10x90 30/10 Item no.: 2105712	HUS3-H 8x75 25/15/5 Item no.: 2079796



General Design Notes

The anchoring system must be verified separately through **Hilti PROFIS Engineering** software or by using the **Hilti Fastening Technology Manual**, considering the real forces acting on the anchor and the actual boundary conditions for the specific application. To give a non-exhaustive example, the strength class of the concrete, the presence of edges close to the anchor and the base material thickness should all be considered.



MQS System

Seismic Designed Solutions

The data and results must be checked for agreement with the actual circumstances and for plausibility. The appropriate specifications, in particular DIN/ EN/ ASTM standards and building/construction legislation, must be observed as seen fit at ones own responsibility. All rights including copyright reserved for HILTI AG. Duplication of this drawing, as well as utilization and disclosure, is not permitted unless expressly agreed.

STRUCTURAL ATTACHMENT ON HOLLOW BRICK

Fastening of seismic rod bracing

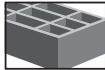
Base material
 Hollow brick

Seismic hinge MQS-AP

	Chemical anchor 	Anchor rod or threaded rod
MQS-AP-8 Item no.: 2330874	HIT-HY 270 Item no.: 2092829	Threaded rod M8
MQS-AP-10 Item no.: 2330875	HIT-HY 270 Item no.: 2092829	Threaded rod M10
MQS-AP-12 Item no.: 2330876	HIT-HY 270 Item no.: 2092829	Threaded rod M12

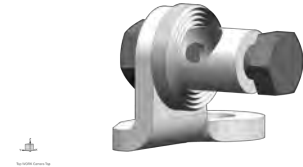

Seismic hinge MQS-CH

	Chemical anchor 	Anchor rod or threaded rod
MQS-CH Item no.: 2083741	HIT-HY 270 Item no.: 2092829	M10



Seismic hinge MQS-AC

	Chemical anchor 	Anchor rod or threaded rod
MQS-AC-10 Item no.: 2083725	HIT-HY 270 Item no.: 2092829	M10
MQS-AC-12 Item no.: 2083726	HIT-HY 270 Item no.: 2092829	M12



Seismic hinge MQS-AC

	Chemical anchor 	Anchor rod or threaded rod
MW-C Item no.: 2287563	HIT-HY 270 Item no.: 2092829	M10



General Design Notes

The anchoring system must be verified separately through **Hilti PROFIS Engineering** software or by using the **Hilti Fastening Technology Manual**, considering the real forces acting on the anchor and the actual boundary conditions for the specific application. To give a non-exhaustive example, the strength class of the concrete, the presence of edges close to the anchor and the base material thickness should all be considered.



MQS System



Seismic Designed Solutions

The data and results must be checked for agreement with the actual circumstances and for plausibility. The appropriate specifications, in particular DIN/ EN/ ASTM standards and building/construction legislation, must be observed as seen fit at ones own responsibility. All rights including copyright reserved for HILTI AG. Duplication of this drawing, as well as utilization and disclosure, is not permitted unless expressly agreed.

MEDIA INTERFACE

Piping – single pipe

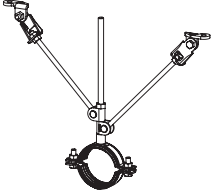
Recommendations on type of application and type of pipe ring for the correct transfer of horizontal seismic loads, according to typical in Chapter 3

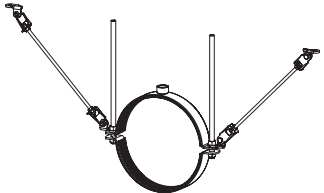
Application	Pipe	
	Dimension	Pipe ring
Single rod hanging – seismic bracing installed on vertical rod 	$\varnothing < 4''$	MP-MI ¹⁾
Single rod hanging – seismic bracing installed on pipe ring flanges 	$4'' \leq \varnothing < 324 \text{ mm}$	MP-MX ²⁾ MP-MXI ³⁾
Double rod hanging – seismic bracing installed on pipe ring flanges 	$\varnothing \geq 324 \text{ mm}$	MP-MX ²⁾ MP-MXI ³⁾

1) MP-MI pipe rings

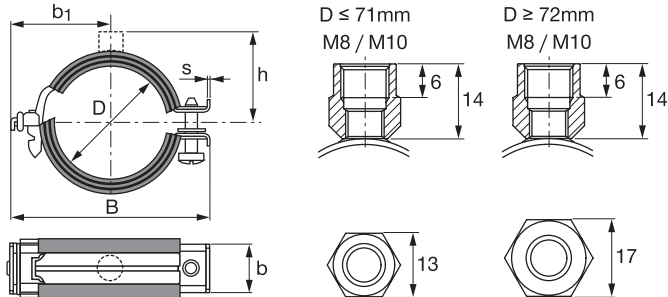

2) MP-MX pipe rings

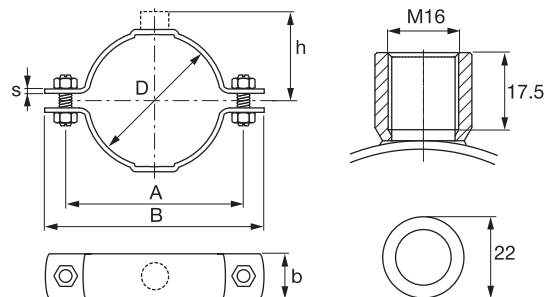

3) MP-MXI pipe rings

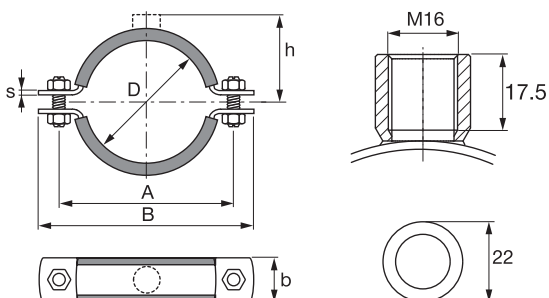

MEDIA INTERFACE

Piping – multiple pipe

Recommendations on type of application and type of pipe ring for the correct transfer of horizontal seismic loads, according to typical in Chapter 3

Based on pipe ring type (and pipe diameter as a consequence), the table shows:

- Threaded rod diameter recommended to fix pipe-ring to the channel
- Pipe ring saddle nut (MQA type), for the fixation of the rod to the channel
- Max distance **h** from the connection boss to the horizontal channel
- Min distance **d** from the vertical channel (for the longitudinal bracing installation)

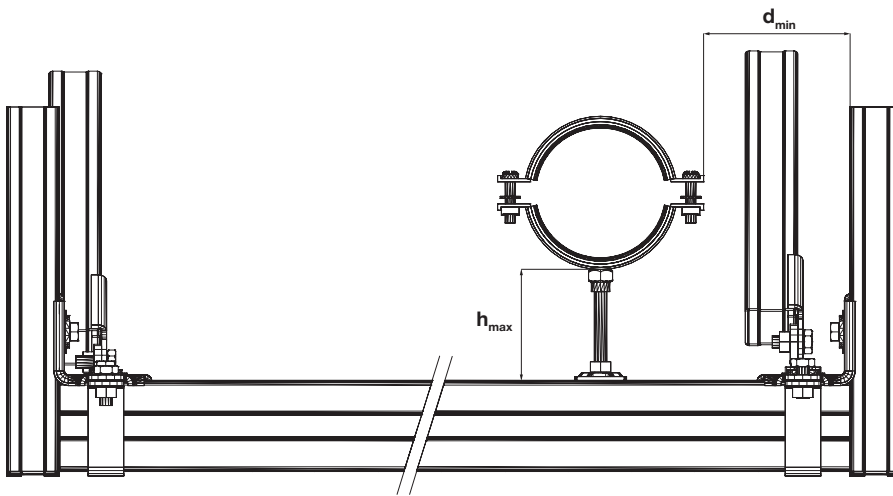



Pipe ring	Rod diameter	Pipe ring saddle	h_{max} [mm]	d_{min} [mm]
MP-MI	M12	MQA-B M12	100	100
MP-MX(I) $\varnothing \leq 3''$	M12	MQA-B M12	100	100
MP-MX(I) $\varnothing > 3''$	M16	MQA-B M16	100	100

MEDIA INTERFACE

Ventilation air ducts (without insulation)

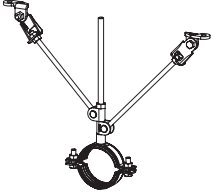
Recommendations on type of bracing for circular ventilation air ducts (without insulation)

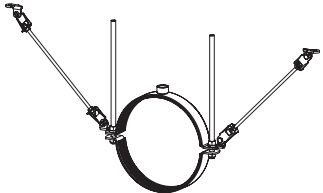
Application	Circular air duct (without sound insulation)	
	Dimension	Pipe ring
Single rod hanging – seismic bracing installed on vertical rod 	$\varnothing < \text{DN } 560$	MV-P
Single rod hanging – seismic bracing installed on pipe ring flanges 	$\text{DN } 560 \leq \varnothing \leq \text{DN } 630$	MV-P
Double rod hanging – seismic bracing installed on pipe ring flanges 	$\varnothing > \text{DN } 630$	MV-P

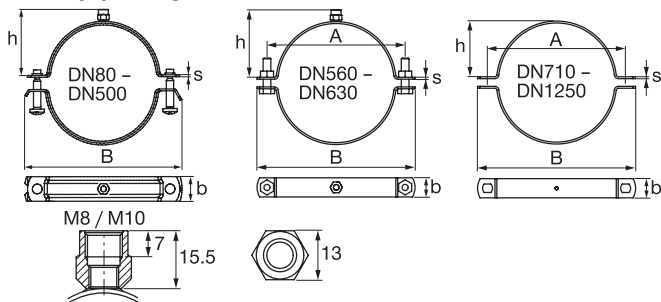

MV-P pipe rings



MEDIA INTERFACE

Ventilation air ducts (with insulation)

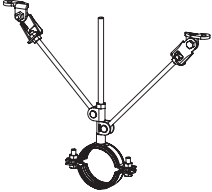
Recommendations on type of bracing for circular ventilation air ducts (with insulation)

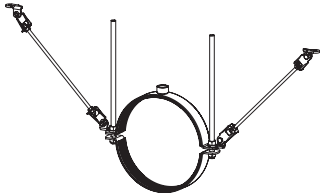
Application	Circular air duct (with sound insulation)	
	Dimension	Pipe ring
Single rod hanging – seismic bracing installed on vertical rod		$\varnothing < \text{DN } 500$ MV-PI
Single rod hanging – seismic bracing installed on pipe ring flanges		$\text{DN } 500 \leq \varnothing \leq \text{DN } 630$ MV-PI
Double rod hanging – seismic bracing installed on pipe ring flanges		$\varnothing > \text{DN } 630$ MV-PI

MV-PI pipe rings

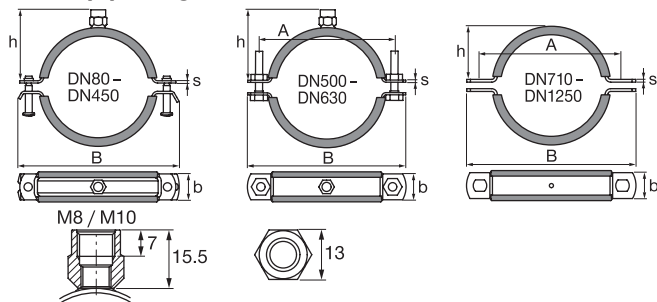

MEDIA INTERFACE

Cable trays

Recommendations on type of connections for cable trays

Application	Fastening	
	Channel accessory	Cable tray accessory
<p>Cable tray</p>	<p>Wing nut MQM – according given bolts</p>	<p>Bolt – according to specification of cable tray manufacturer</p>
<p>Cable ladder</p>	<p>Wing nut MQM – according given bolts</p>	<p>Clip – according to specification of cable ladder manufacturer</p>

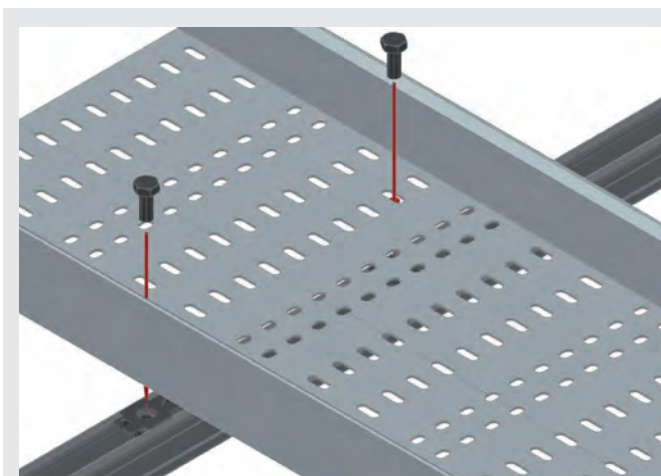

Fig. D.1 – direct fixation using cable tray holes

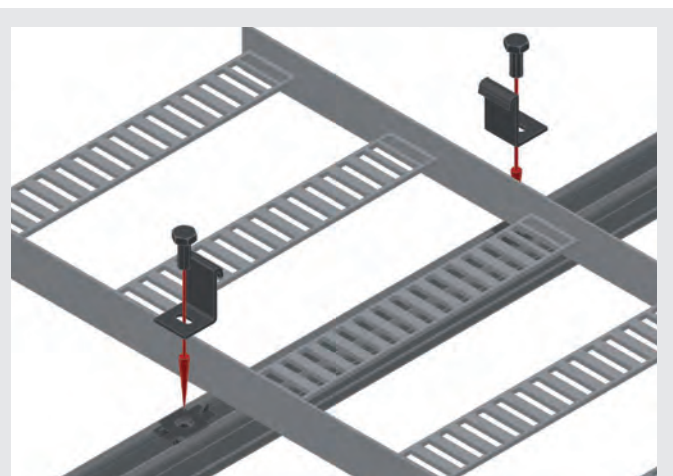
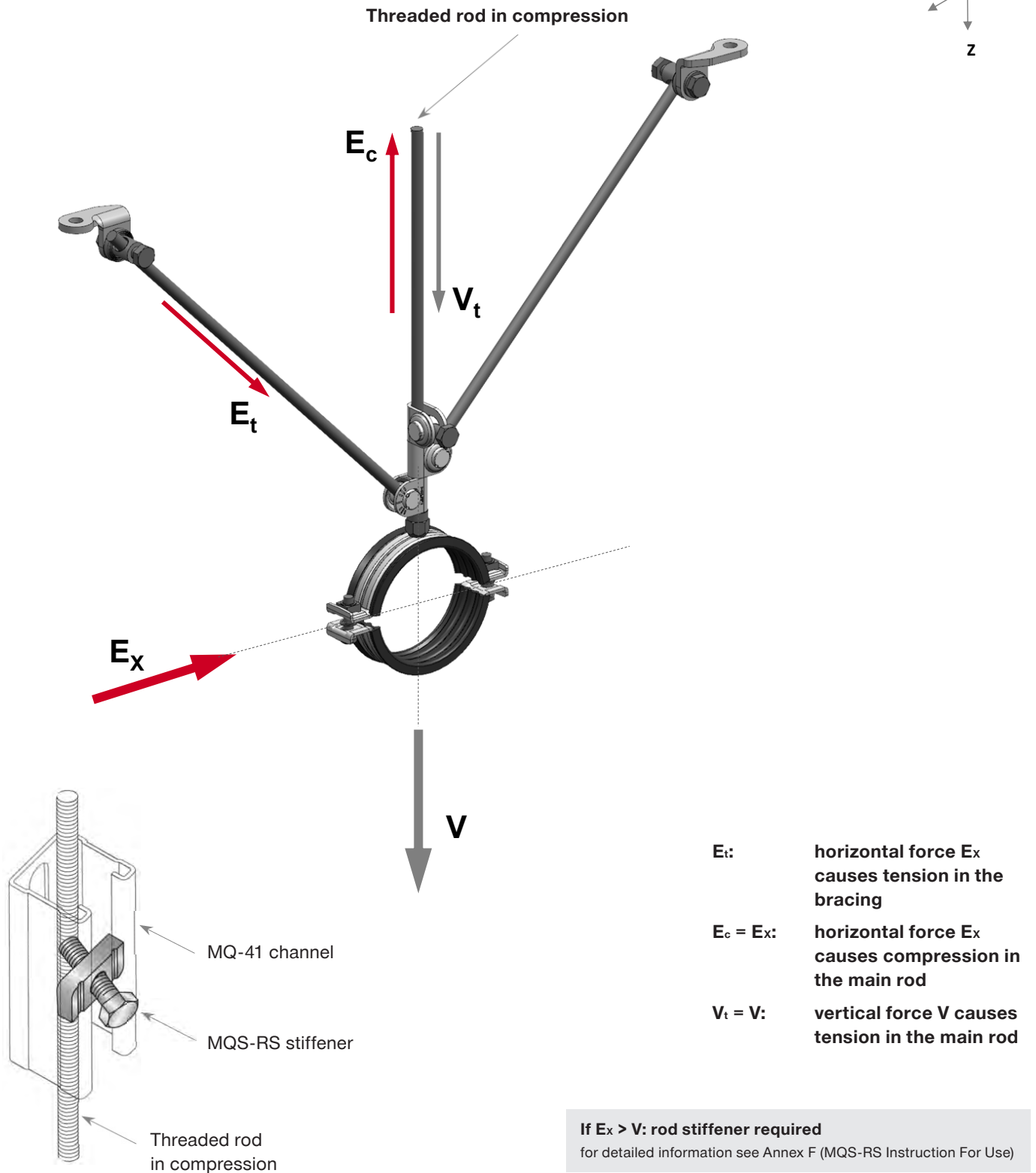
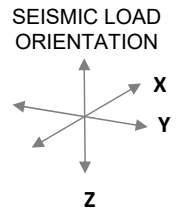
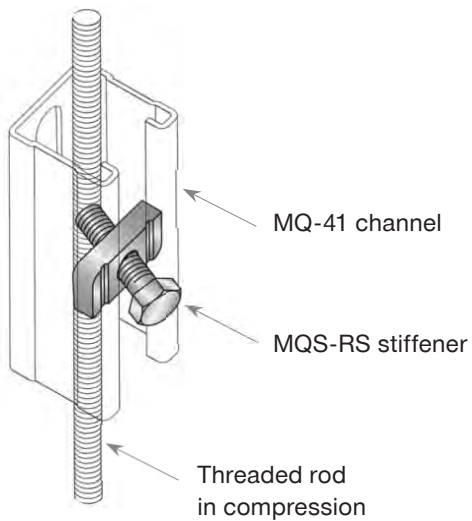
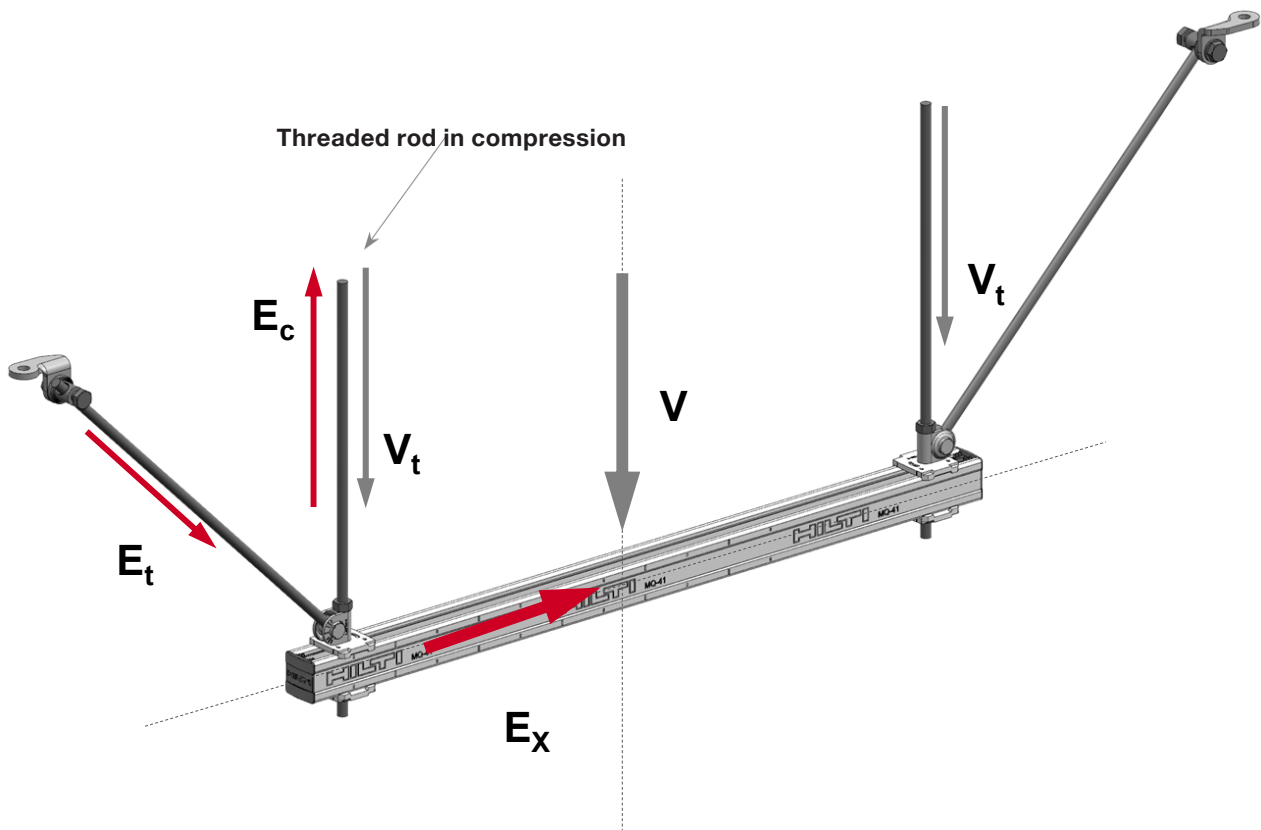
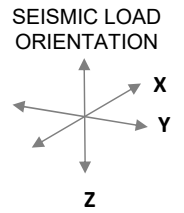

Fig. D.2 – cable ladder fixation with clips

USE OF ROD STIFFENER



USE OF ROD STIFFENER



- E_t :** horizontal force E_x causes tension in the bracing
- $E_c = E_x$:** horizontal force E_x causes compression in the main rod
- $V_t = V/2$:** vertical force V causes tension in the main rod

If $E_x > V/2$: rod stiffener required
 for detailed information see Annex F (MQS-RS Instruction For Use)

PRODUCT DATA SHEET

Seismic hinge MQS-AP with M10 rod bracing

		Design load static and seismic	
		+ F _x	- F _x
MQS-AP-8			
MQS-AP-10	30° ≤ α ≤ 60°	4.60 kN	n.a.
MQS-AP-12			

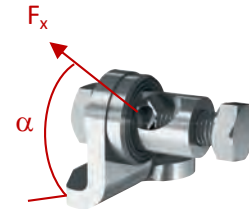

Seismic hinge MQS-CH with M10 rod bracing

		Design load static and seismic	
		+ F _x	- F _x
MQS-CH	30° ≤ α ≤ 60°	4.67 kN	n.a.

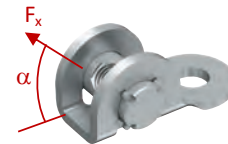

Seismic hinge MQS-HR with M10 rod bracing and M8 or M10 nut as stopper on vertical rod

		Design load static and seismic	
		+ F _x	- F _x
MQS-HR-8			
MQS-HR-10	30° ≤ α ≤ 60°	4.67 kN	n.a.

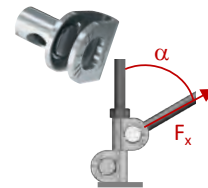

Seismic hinge MQS-HR with M10 rod bracing and third MQS-HR-10 as stopper on vertical rod (e.g. single pipe retrofit)

		Design load static and seismic	
		+ F _x	- F _x
MQS-HR-10	30° ≤ α ≤ 60°	2.85 kN	n.a.

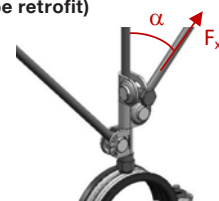

Shown load values are design values (F_{Ed}). The partial safety factor for the action is 1.0 in case of seismic loading and 1.5 in case of any other horizontal life load. Load values are valid for α = 45° ± 15°

Note: final load for a particular seismic support is depending on the set up of the used items.

PRODUCT DATA SHEET

Seismic angle MQS-W set

		Design load static		Design load seismic	
		+ F _x	- F _x	+ F _x	- F _x
MQS-AC to MQS-W set	30° ≤ α < 40°			6.10 kN	6.10 kN
	40° ≤ α ≤ 50°	3.52 kN	3.52 kN	6.10 kN	6.10 kN
	50° < α ≤ 60°			5.60 kN	5.60 kN
MW-LP-L 2.0mm to MQS-W set		0.74 kN	n.a.	1.83 kN	n.a.
MW-LP-L 3.0mm to MQS-W set	30° ≤ α ≤ 60°	1.50 kN	n.a.	2.59 kN	n.a.
MW-LP-L 5.0mm to MQS-W set		3.58 kN	n.a.	6.10 kN	n.a.
MQS-AP to MQS-W set	30° ≤ α ≤ 60°	3.52 kN	n.a.	4.60 kN	n.a.

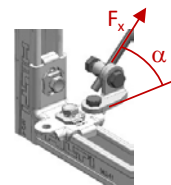
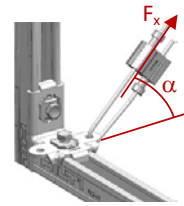
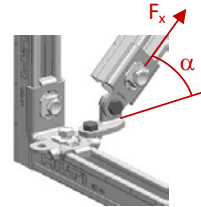

Seismic hinge MQS-AC

		Design load static and seismic	
		+ F _x	- F _x
MQS-AC-10	30° ≤ α ≤ 60°	6.24 kN	6.24 kN
MQS-AC-12			

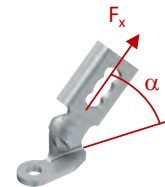

Shown load values are design values (F_{Ed}). The partial safety factor for the action is 1.0 in case of seismic loading and 1.5 in case of any other horizontal life load. Load values are valid for α = 45° ± 15°

Note: final load for a particular seismic support is depending on the set up of the used items.

PRODUCT DATA SHEET

Wire bracing base MW-C

		Design load static	Design load seismic
		+ F _x	+ F _x
MW-C with 2.0 mm wire	30° ≤ α ≤ 60°	0.74 kN	2.12 kN
MW-C with 3.0 mm wire		1.50 kN	3.84 kN
MW-C with 5.0 mm wire		3.58 kN	9.35 kN

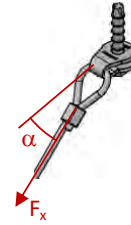

Wire bracing to MQS-HR

		Design load static	Design load seismic
		+ F _x	+ F _x
MQS-HR with 2.0 mm wire	30° ≤ α ≤ 60°	0.74 kN	2.12 kN
MQS-HR with 3.0 mm wire		1.50 kN	3.84 kN
MQS-HR with 5.0 mm wire		3.58 kN	9.35 kN*



Wire bracing to MQS-A

		Design load static	Design load seismic
		+ F _x	+ F _x
MQS-A with 2.0 mm wire	30° ≤ α ≤ 60°	0.74 kN	2.12 kN
MQS-A with 3.0 mm wire		1.50 kN	3.84 kN
MQS-A with 5.0 mm wire		3.58 kN	9.35 kN

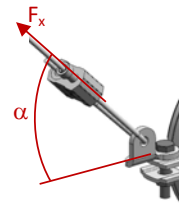

Shown load values are design values (FRd). The partial safety factor for the action is 1.0 in case of seismic loading and 1.5 in case of any other horizontal life load. Load values are valid for α = 45° ± 15°

Note: final load for a particular seismic support is depending on the set up of the used items.

* One MQS-HR only. For stapled application, calculation with PROFIS needed.

PRODUCT DATA SHEET

MQZ-P-9 Rod connection

	Design load static		Design load seismic	
	$\pm F_z$	$\pm F_x$	$\pm F_y$	$\pm F_z$
MQZ-P-9	5.00 kN	1.75 kN	5.00 kN	5.00 kN

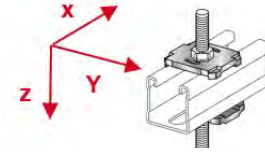

MQZ-L-11 Rod connection

	Design load static		Design load seismic	
	$\pm F_z$	$\pm F_x$	$\pm F_y$	$\pm F_z$
MQZ-L-11	10.00 kN	2.00 kN	5.00 kN	10.00 kN

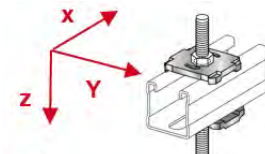

Threaded rod buckling resistance when rod stiffener is used

	Design buckling resistance	
	- F_x	
M8 4.8	3.33 kN	
M10 4.8	3.94 kN	
M12 4.8	4.64 kN	
M16 4.8	9.54 kN	



Shown load values are design values (F_{Rd}). The partial safety factor for the action is 1.0 in case of seismic loading and 1.5 in case of any other horizontal life load. Load values are valid for $\alpha = 45^\circ \pm 15^\circ$

Note: final load for a particular seismic support is depending on the set up of the used items!

INSTRUCTION FOR USE

MQS-AP

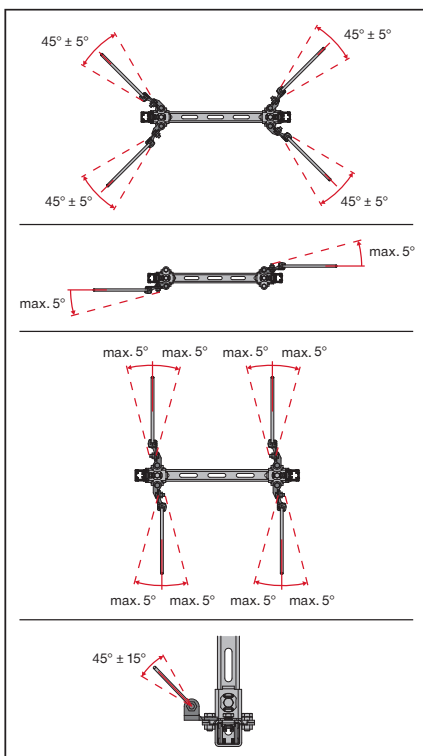
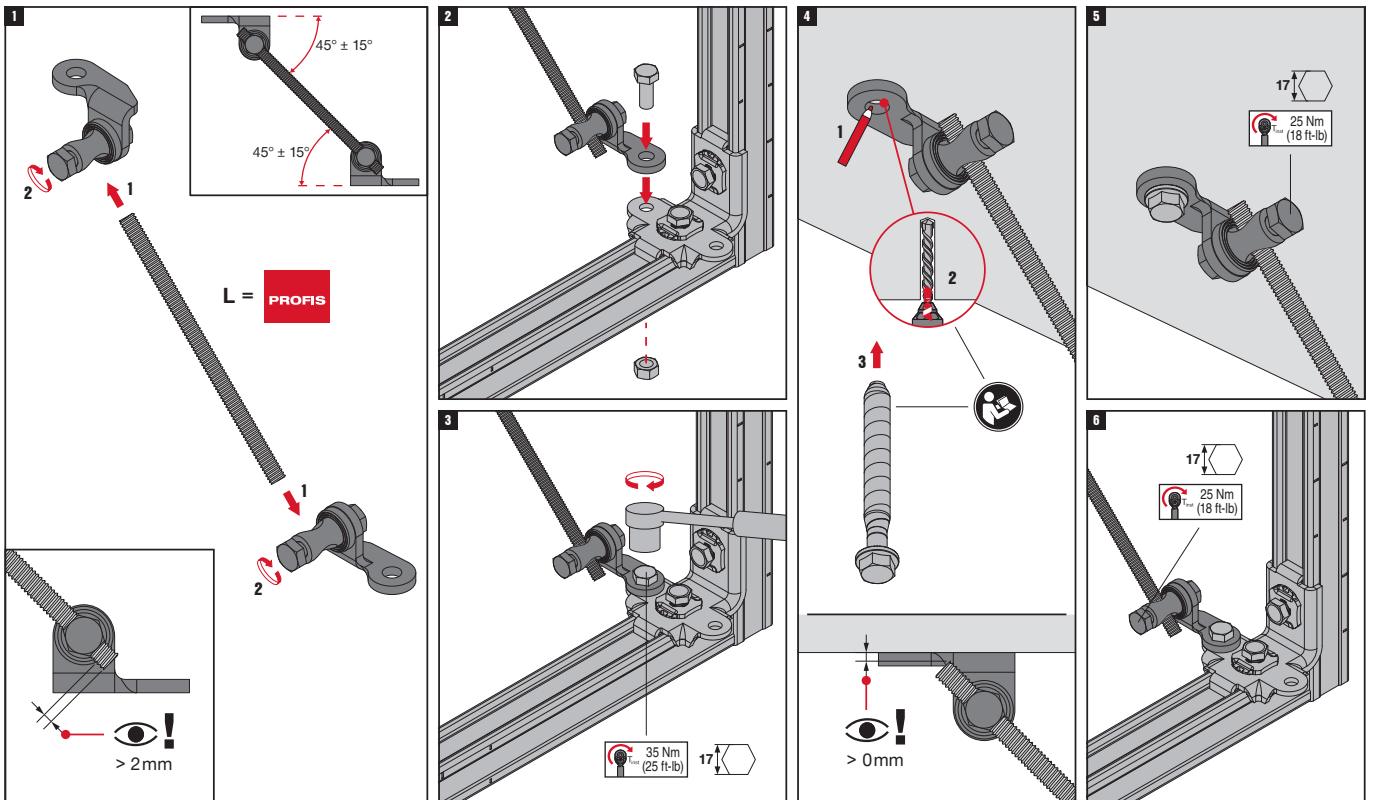

INSTRUCTION FOR USE

MQS-HR

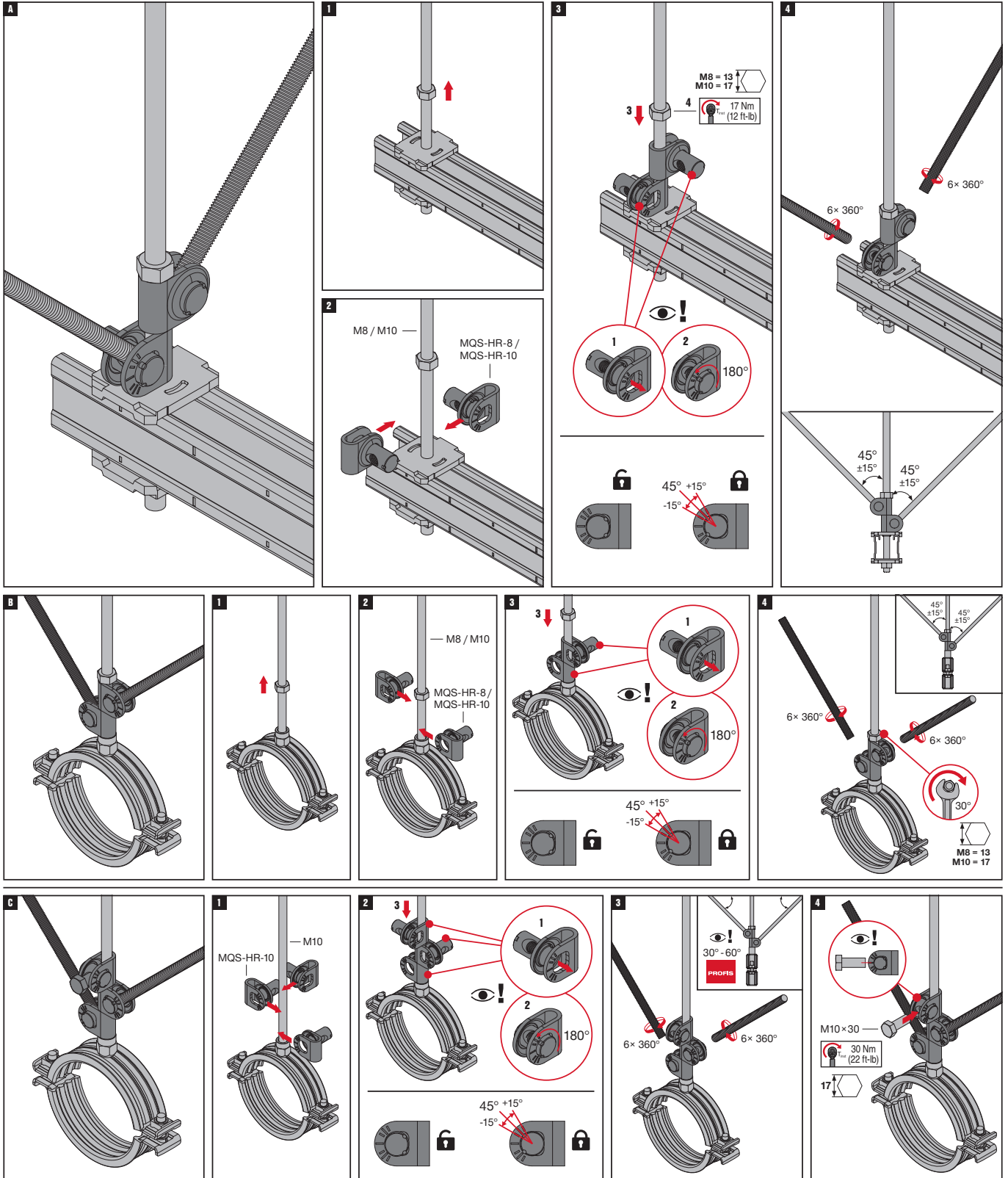

INSTRUCTION FOR USE

MQS-W set

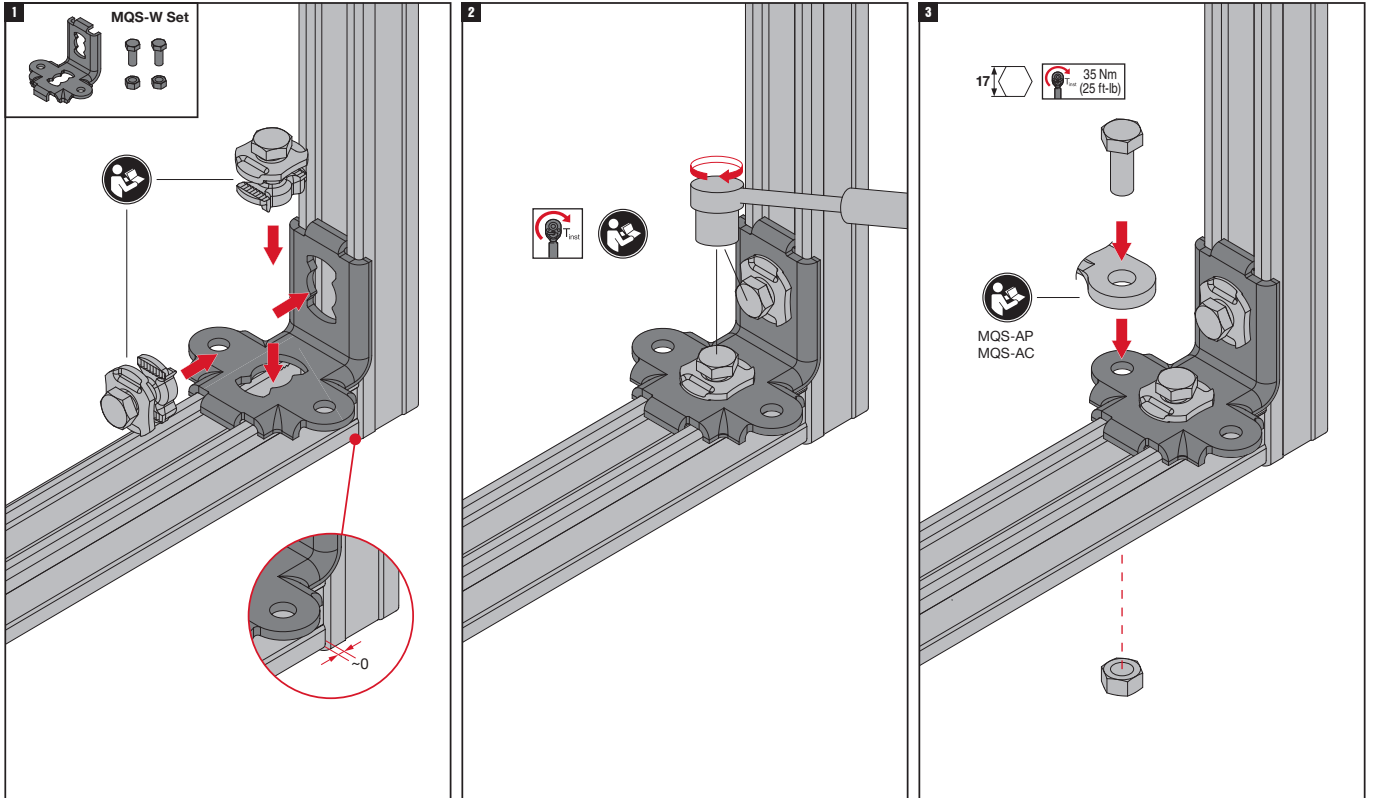

INSTRUCTION FOR USE

MQS-CH

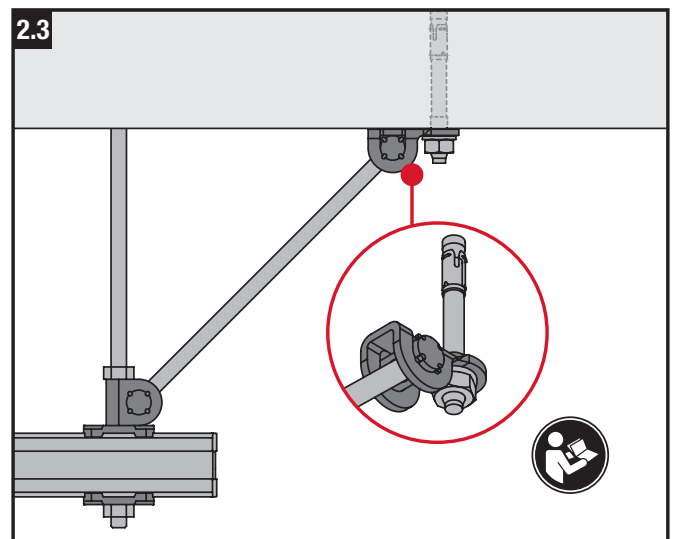
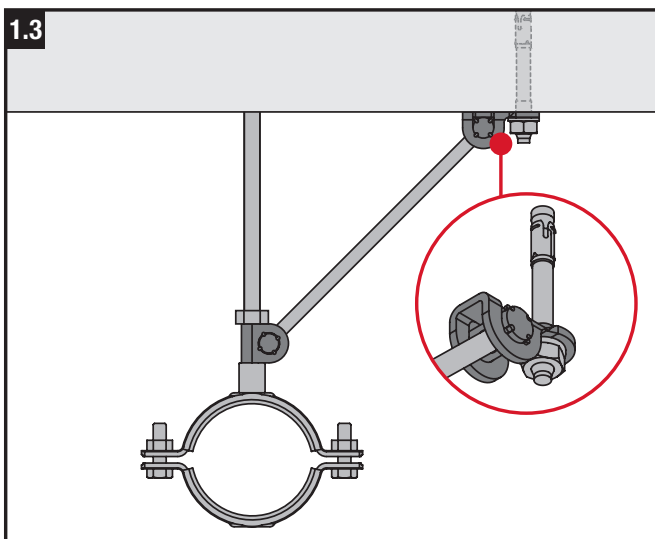
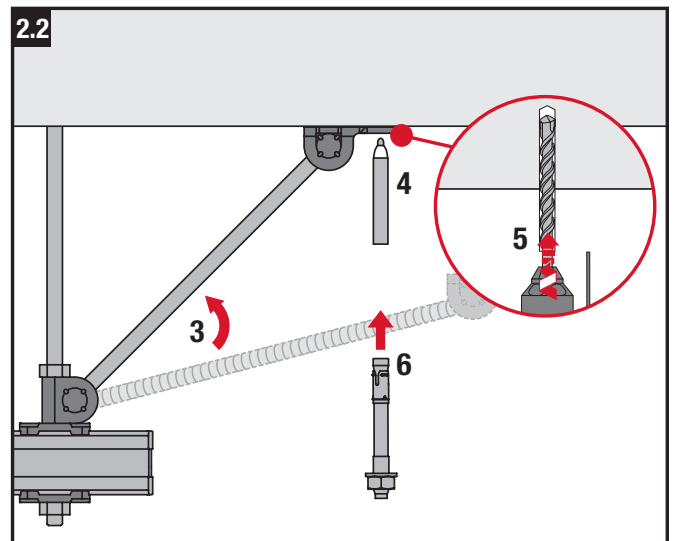
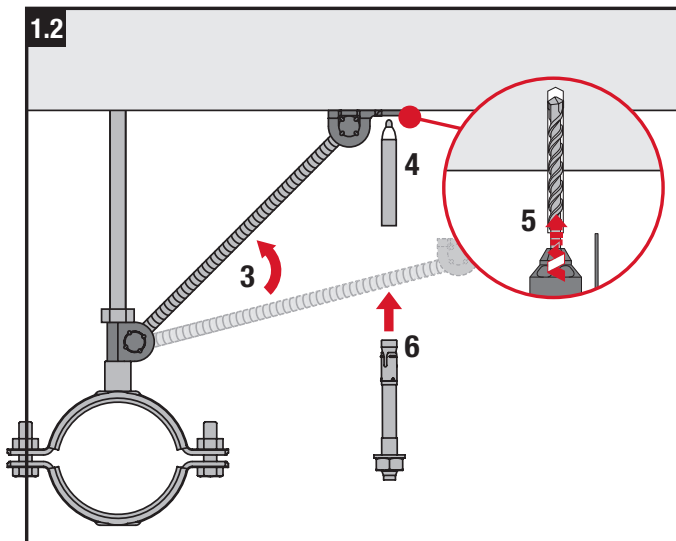
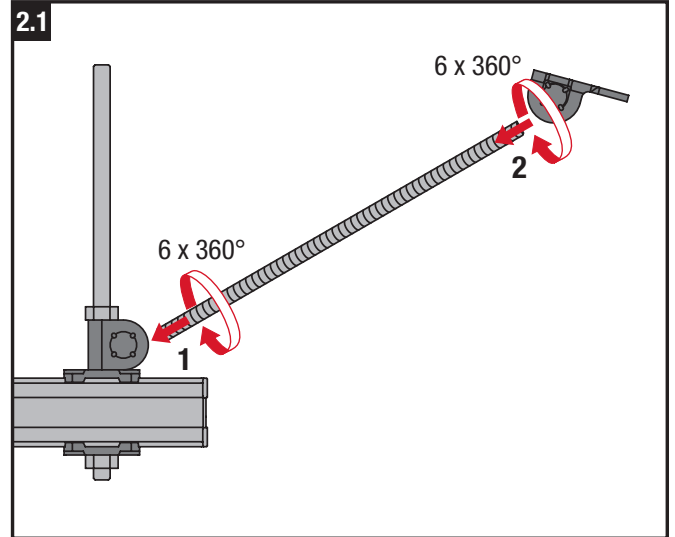
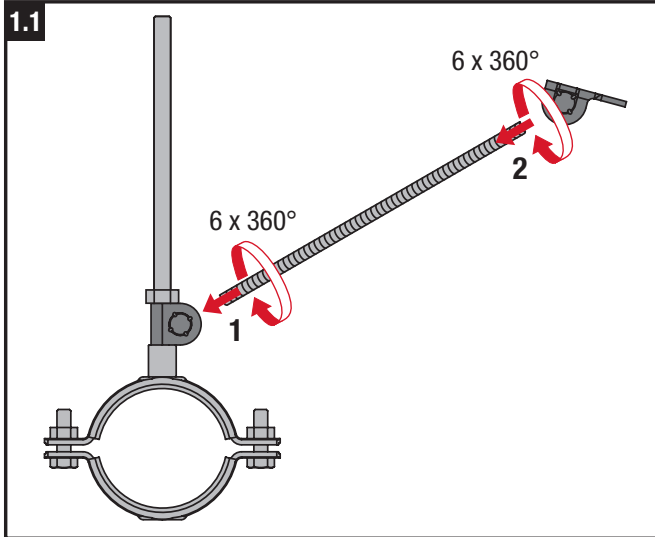

INSTRUCTION FOR USE
MQS-RS

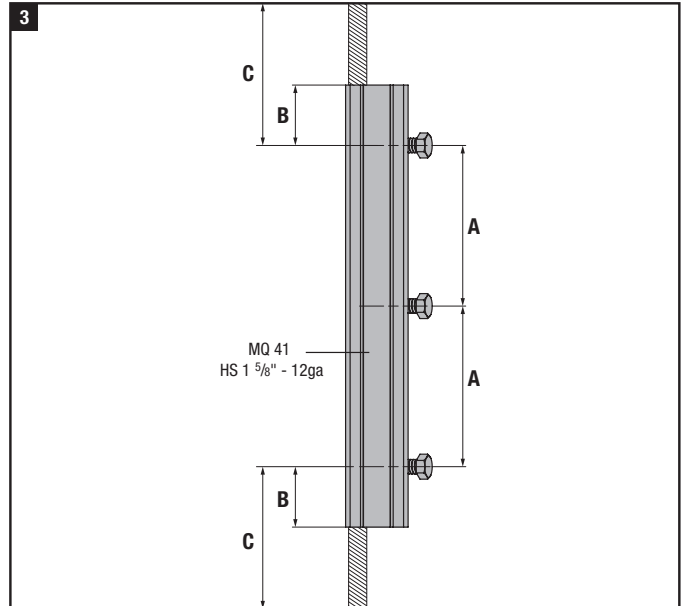
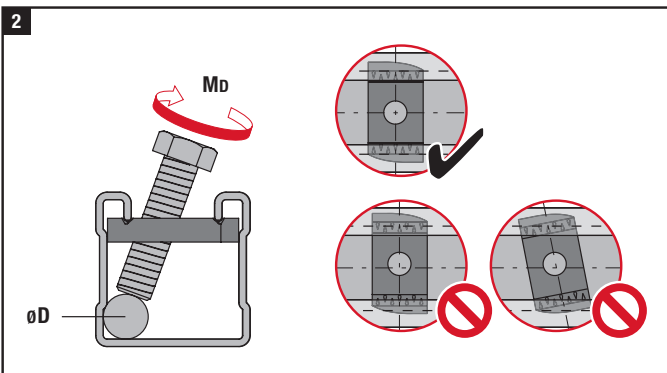
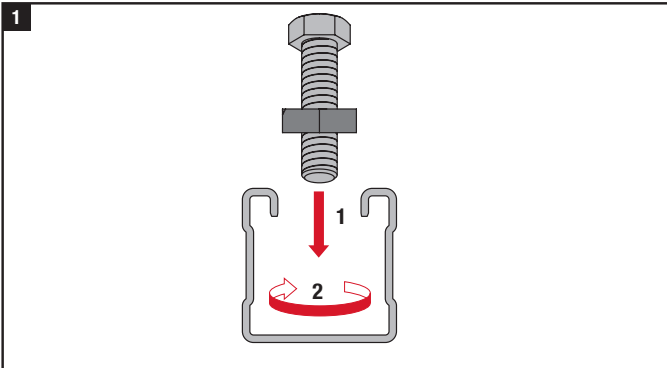

ØD	max A	max A	min B	max C
M8	11 Nm	220 mm	50 mm	120 mm
M10		330 mm		150 mm
M12		450 mm		
M16		580 mm		



Hilti Corporation
9494 Schaan, Liechtenstein
P +423-234 2965

www.facebook.com/hiltigroup
www.hilti.group