



INSTYTUT TECHNIKI BUDOWLANEJ
PL 00-611 WARSZAWA
ul. Filtrowa 1
tel.: (+48 22) 825-04-71
(+48 22) 825-76-55
www.itb.pl



Member of



www.eota.eu

European Technical Assessment

ETA-21/0414 of 27/07/2021

General Part

Technical Assessment Body issuing the European Technical Assessment

Instytut Techniki Budowlanej

Trade name of the construction product

HILTI installation channels of MT System

Product family to which the construction product belongs

Products for installation systems for supporting technical building equipment

Manufacturer

HILTI AG
Feldkircherstraße 100
9494 Schaan
FÜRSTENTUM LIECHTENSTEIN

Manufacturing plants

L 1138282, L 8321

This European Technical Assessment contains

17 pages including 3 Annexes which form an integral part of this Assessment

This European Technical Assessment is issued in accordance with regulation (EU) No 305/2011, on the basis of

European Assessment Document EAD 280016-00-0602 "Products for installation systems for supporting technical building equipment"

This European Technical Assessment is issued by the Technical Assessment Body in its official language. Translations of this European Technical Assessment in other languages shall fully correspond to the original issued document and shall be identified as such.

Communication of this European Technical Assessment, including transmission by electronic means, shall be in full. However, partial reproduction may only be made with the written consent of the issuing Technical Assessment Body. Any partial reproduction has to be identified as such.

Specific Part

1 Technical description of the product

This European Technical Assessment covers HILTI installation channels of MT System: MT-10, MT-15, MT-15 OC, MT-20, MT-20 OC, MT-30 S, MT-30, MT-30 S OC, MT-30 OC, MT-40 T, MT-40 T OC, MT-40 S, MT-40, MT-40 S OC, MT-40 OC, MT-50 S, MT-50, MT-50 S OC, MT-50 OC, MT-60 S, MT-60, MT-60 S OC, MT-60 OC, MT-70 S OC, MT-70 OC, MT-80 S OC, MT-80 OC, MT-90 S OC, MT-90 OC, MT-100 S OC, MT-100 OC, MT-40D S, MT-40D, MT-40D S OC and MT-40D OC.

The HILTI installation channels: MT-10, MT-15, MT-15 OC, MT-20 and MT-20 OC are made of thin-walled steel in L- or C shape. Recesses in the form of oblong holes and round holes allow the use of fasteners and fixtures.

The HILTI installation channels: MT-30 S, MT-30, MT-30 S OC, MT-30 OC, MT-40 T, MT-40 T OC, MT-40 S, MT-40, MT-40 S OC, MT-40 OC, MT-50 S, MT-50, MT-50 S OC, MT-50 OC, MT-60 S, MT-60, MT-60 S OC and MT-60 OC are made of thin-walled steel in C shape. The profile flanges are turned at the end which makes it possible to force-fit the channels to specific channel system fixtures. Recesses in the form of oblong holes and round holes allow the use of fasteners and fixtures.

The HILTI installation channels: MT-70 S OC, MT-70 OC, MT-80 S OC, MT-80 OC, MT-90 S OC, MT-90 OC, MT-100 S OC and MT-100 OC are made of thin-walled steel closed profiles in square or rectangular shape with recesses in the form of round holes to allow use of fasteners and fixtures.

The HILTI installation channels: MT-40D S, MT-40D, MT-40D S OC and MT-40D OC consists of two profiles of similar types as MT-40 S, MT-40, MT-40 S OC and MT-40 OC which are connected in the area of back of the channels in a shape-fitting and force-fitting way.

The channels are delivered in length of 2 m for the channels MT-10, MT-15, MT-15 OC, MT-20 and MT-20 OC and in the lengths of 3 m or 6 m for the channels MT-30 S, MT-30, MT-30 S OC, MT-30 OC, MT-40 T, MT-40 T OC, MT-40 S, MT-40, MT-40 S OC, MT-40 OC, MT-50 S, MT-50, MT-50 S OC, MT-50 OC, MT-60 S, MT-60, MT-60 S OC, MT-60 OC, MT-70 S OC, MT-70 OC, MT-80 S OC, MT-80 OC, MT-90 S OC, MT-90 OC, MT-100 S OC, MT-100 OC, MT-40D S, MT-40D, MT-40D S OC and MT-40D OC. The channels can be cut to length as required.

The drawings, dimensions and materials of the HILTI installation channels of MT System are given in Annex A.

2 Specification of the intended use in accordance with the applicable European Assessment Document (EAD)

The performances given in clause 3 are only valid if HILTI installation channels of MT System are in compliance with the specifications and conditions given in Annex B.

The provisions made in this European Technical Assessment are based on an assumed working life of the HILTI installation channels of MT System of 50 years. The indications given on the working life cannot be interpreted as a guarantee given by the producer or Technical Assessment Body, but are to be regarded only as a means for choosing the right products in relation to the expected economically reasonable working life of the works.

In accordance with the European Assessment Document EAD 280016-00-0602, the products are intended to be used under dry indoor conditions for supporting:

- pipes for the transport of water not intended for human consumption,
- pipes for the transport of gas/fuel intended for the supply of building heating/cooling systems,
- technical building equipment in general,
- components of fixed fire-fighting systems.

3 Performance of the product and references to the methods used for its assessment

3.1 Performance of the product

3.1.1 Safety in case of fire (BWR 2)

Essential characteristic	Performance
Reaction to fire	Class A1
Pull-through resistance of channel back holes under fire exposure	No performance assessed
Bending characteristics under fire exposure	No performance assessed

3.1.2 Safety and accessibility in use (BWR 4)

Essential characteristic	Performance
Shape	Annex A
Dimensions	Annex A
Materials and cross-section characteristics	Annexes A and B
Characteristic pull-through resistance of channel back holes	No performance assessed

3.2 Methods used for the assessment

The assessment of the products has been made in accordance with the European Assessment Document EAD 280016-00-0602 "Products for installation systems for supporting technical building equipment".

4 Assessment and verification of constancy of performance (AVCP) system applied, with reference to its legal base

For products for installation systems to be used for supporting pipes for the transport of water not intended for human consumption, according to the Decision 1999/427/EC of the European Commission, amended by the Decision 2001/596/EC, the system 4 of assessment and verification of constancy of performance (see Annex V to the regulation (EU) No 305/2011) applies.

For products for installation systems intended to be used for supporting pipes for the transport of gas/fuel intended for the supply of building heating/cooling systems, according to the Decision 1999/427/EC of the European Commission, amended by the Decision 2001/596/EC, the system 3 of assessment and verification of constancy of performance (see Annex V to the regulation (EU) No 305/2011) applies.

For products for installation systems intended to be used for supporting technical building equipment in general according to the Decision 97/161/EC of the European Commission, the system 2+ of assessment and verification of constancy of performance (see Annex V to the regulation (EU) No 305/2011) applies.

For products for installation systems intended to be used for supporting components of fixed fire-fighting systems according to Decision 96/577/EC of the European Commission, as amended by the Decision 2002/592/EC, the system 1 of assessment and verification of constancy of performance (see Annex V to the regulation (EU) No 305/2011) applies.

5 Technical details necessary for the implementation of the AVCP system, as provided in the applicable European Assessment Document (EAD)

Technical details necessary for the implementation of the AVCP system are laid down in the control plan deposited in Instytut Techniki Budowlanej.

For the type testing the results of the tests performed as part of the assessment for the European Technical Assessment shall be used unless there are changes in the production line or plant. In such cases the necessary type testing has to be agreed between Instytut Techniki Budowlanej and the notified body.

Issued in Warsaw on 27/07/2021 by Instytut Techniki Budowlanej

A handwritten signature in blue ink, appearing to read 'R. Geryło'.

Robert Geryło, Ph.D
Director of ITB

Table A1: Shape, dimensions and materials of channels MT-10, MT-15, MT-15 OC, MT-20 and MT-20 OC

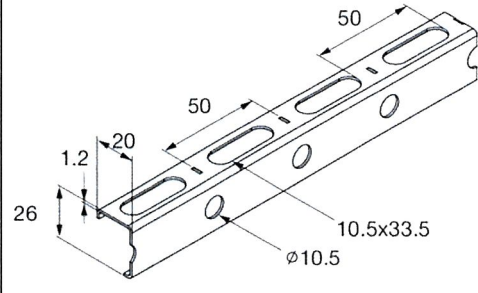
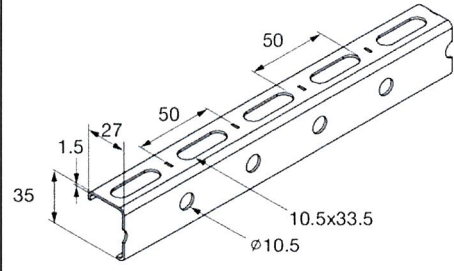
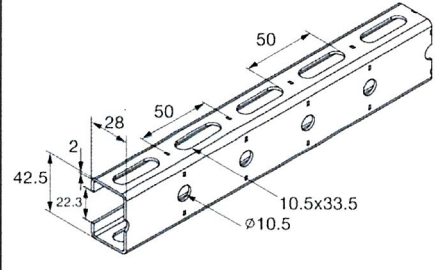
Shape	Item number	Designation	Length [m]	Material
	2268492	MT-10	2	S280GD+ Z275-M-A-C acc. to EN 10346
	2268493	MT-15	2	S280GD+ Z275-M-A-C acc. to EN 10346
	2268494	MT-15 OC	2	S280GD+ ZM310-A-C acc. to EN 10346
	2268495	MT-20	2	S280GD+ Z275-M-A-C acc. to EN 10346
	2268496	MT-20 OC	2	S280GD+ ZM310-A-C acc. to EN 10346

HILTI installation channels of MT System

Product description
Shape, dimensions and materials of channels MT-10, MT-15, MT-15 OC, MT-20 and MT-20 OC

Annex A1
of European
Technical Assessment
ETA-21/0414

Table A2: Shape, dimensions and materials of channels MT-30 S, MT-30, MT-30 S OC, MT-30 OC, MT-40 T and MT-40 T OC

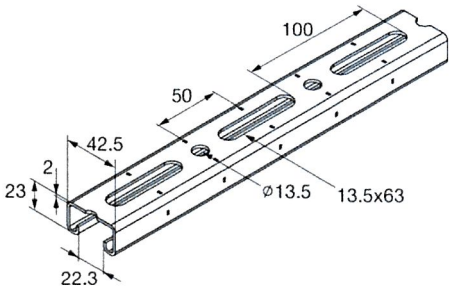
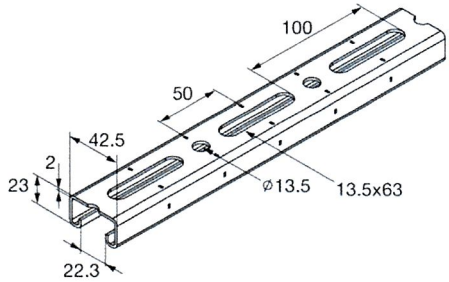
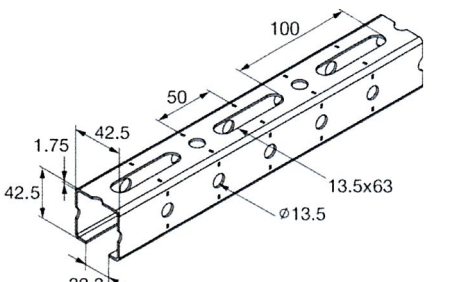
Shape	Item number	Designation	Length [m]	Material
	2268497	MT-30 S	3	S250GD+ Z275-M-A-C acc. to EN 10346
	2268498	MT-30	6	
	2268499	MT-30 S OC	3	S250GD+ ZM310-A-C acc. to EN 10346
	2268500	MT-30 OC	6	
	2268502	MT-40 T	3 6	S280GD+ Z275-M-A-C acc. to EN 10346
	2268504	MT-40 T OC	3 6	

HILTI installation channels of MT System

Product description
Shape, dimensions and materials of channels MT-30 S, MT-30, MT-30 S OC, MT-30 OC, MT-40T and MT-40 T OC

Annex A2
of European
Technical Assessment
ETA-21/0414

Table A3: Shape, dimensions and materials of channels MT-40 S, MT-40, MT-40 S OC, MT-40 OC, MT-50 S and MT-50

Shape	Item number	Designation	Length [m]	Material
	2268505	MT-40 S	3	S280GD+ Z275-M-A-C acc. to EN 10346
	2268506	MT-40	6	
	2268507	MT-40 S OC	3	S280GD+ ZM310-A-C acc. to EN 10346
	2268508	MT-40 OC	6	
	2268509	MT-50 S	3	S280GD+ Z275-M-A-C acc. to EN 10346
	2268510	MT-50	6	

HILTI installation channels of MT System

Product description

Shape, dimensions and materials of channels MT-40 S, MT-40, MT-40 S OC, MT-40 OC, MT-50 S and MT-50

Annex A3
of European
Technical Assessment
ETA-21/0414

Table A4: Shape, dimensions and materials of channels MT-50 S OC, MT-50 OC, MT-60 S, MT-60, MT-60 S OC and MT-60 OC

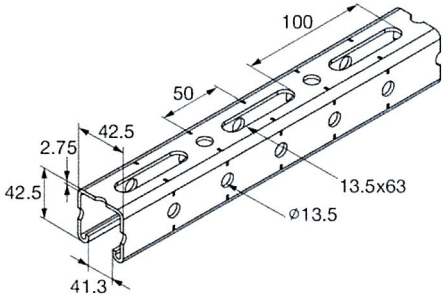
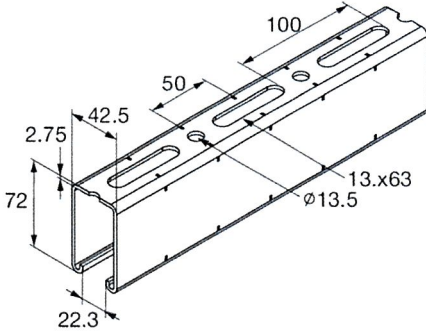
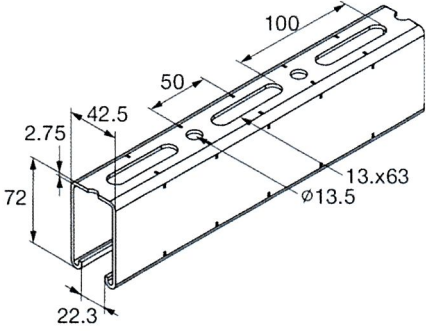
Shape	Item number	Designation	Length [m]	Material
	2268511	MT-50 S OC	3	S280GD+ ZM310-A-C acc. to EN 10346
	2268512	MT-50 OC	6	
	2268513	MT-60 S	3	S280GD+ Z275-M-A-C acc. to EN 10346
	2268514	MT-60	6	
	2268515	MT-60 S OC	3	S280GD+ ZM310-A-C acc. to EN 10346
	2268516	MT-60 OC	6	

HILTI installation channels of MT System

Product description

Shape, dimensions and materials of channels MT-50 S OC, MT-50 OC, MT-60 S, MT-60, MT-60 S OC and MT-60 OC

Annex A4

of European
Technical Assessment
ETA-21/0414

Table A5: Shape, dimensions and materials of channels MT-70 S OC, MT-70 OC, MT-80 S OC, MT-80 OC, MT-90 S OC and MT-90 OC

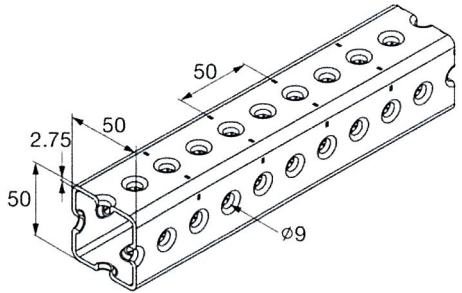
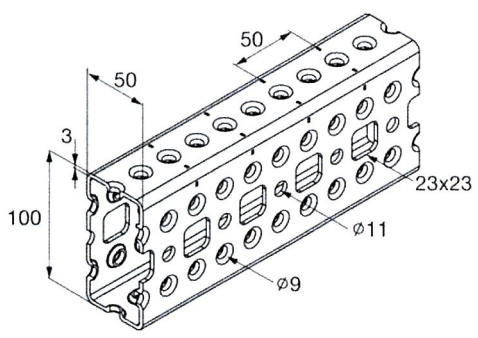
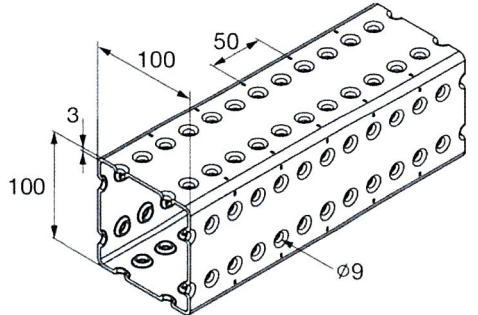
Shape	Item number	Designation	Length [m]	Material
	2268364	MT-70 S OC	3	S350GD+ ZM310-A-C acc. to EN 10346
	2268365	MT-70 OC	6	
	2268366	MT-80 S OC	3	S350GD+ ZM310-A-C acc. to EN 10346
	2268367	MT-80 OC	6	
	2268368	MT-90 S OC	3	S350GD+ ZM310-A-C acc. to EN 10346
	2268369	MT-90 OC	6	

HILTI installation channels of MT System

Product description

Shape, dimensions and materials of channels MT-70 S OC, MT-70 OC, MT-80 S OC, MT-80 OC, MT-90 S OC and MT-90 OC

Annex A5

of European
Technical Assessment
ETA-21/0414

Table A6: Shape, dimensions and materials of channels MT-100 S OC, MT-100 OC, MT-40D S, MT-40D, MT-40D S OC and MT-40D OC

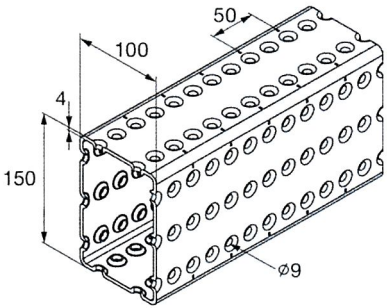
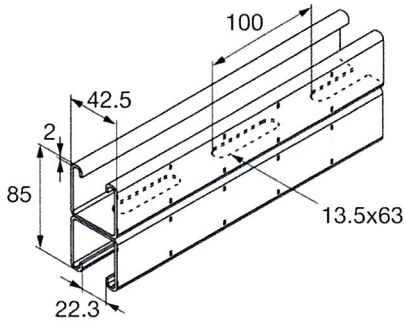
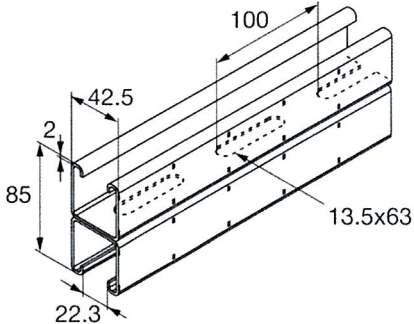
Shape	Item number	Designation	Length [m]	Material
	2268490	MT-100 S OC	3	S350GD+ ZM310-A-C acc. to EN 10346
	2268491	MT-100 OC	6	
	2268517	MT-40D S	3	S280GD+ Z275-M-A-C acc. to EN 10346
	2268518	MT-40D	6	
	2268519	MT-40D S OC	3	S280GD+ ZM310-A-C acc. to EN 10346
	2268520	MT-40D OC	6	

HILTI installation channels of MT System

Product description

Shape, dimensions and materials of channels MT-100 S OC, MT-100 OC, MT-40D S, MT-40 D, MT-40D S OC and MT-40D OC

Annex A6

of European
Technical Assessment
ETA-21/0414

Specification of intended use

- HILTI installation channels of MT System are used only for applications at ambient temperature.
- The resistance and deformation apply for static and centric loads.
- In the case of open profile channels, the open side of the channel profile can be orientated in all directions.
- The installation open profile channels and closed profile can be cut anywhere along the whole length.
- For closed profiles the distance between the end of the profile and start of the round hole has to be minimum 10 mm.

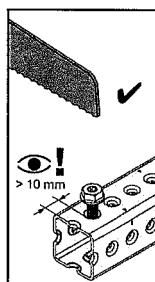

- For open profiles the distance between the end of the profile and center of the first round hole has to be minimum 25 mm.

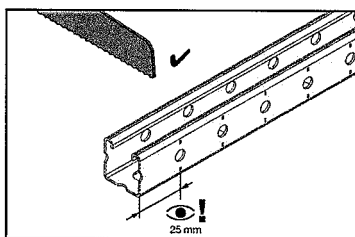

- Threaded rods and other fixtures are only to be guided through the roundholes or longholes of the channel.
- Prior to installation, it must be ensured that the components to be supported by the installation channels, the connection components, the anchoring of the channels to the base material and the base material itself are suitable to withstand the resistance values of the channels as well as installation systems.
- The installation channels must be installed by appropriately qualified personnel and under the supervision of the site manager, according to the instruction of the manufacturer.

HILTI installation channels of MT System	Annex B1 of European Technical Assessment ETA-21/0414
Intended use Specifications	

Table C1. Properties of the cross section of channels MT-10, MT-15, MT-15 OC, MT-20 and MT-20 OC

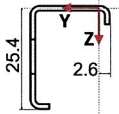
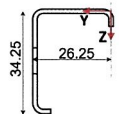
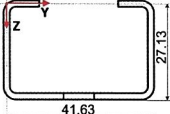
Description	Symbol	Unit	MT-10	MT-15 / MT-15 OC	MT-20 / MT-20 OC
Cross section (dimensions in mm)	-	-			
Classification cross section in accordance with EN 1993-1-1	-	-	3	3	3
Cross section areas	A	cm ²	0.49	0.85	1.49
	A _{tot}	cm ²	0.49	0.85	1.49
Shear areas	A _y	cm ²	0.08	0.15	0.36
	A _z	cm ²	0.17	0.30	0.35
Centroid position	y _{C,0}	cm	1.22	1.93	2.02
	z _{C,0}	cm	0.92	1.19	1.64
Moments of inertia	I _y	cm ⁴	0.41	1.27	1.86
	I _z	cm ⁴	0.23	0.72	3.66
Polar moments of inertia	I _p	cm ⁴	0.64	1.98	5.52
	I _{p,M}	cm ⁴	1.26	3.80	14.71
Radii of gyration	i _y	cm	0.91	1.22	1.12
	i _z	cm	0.69	0.92	1.57
Polar radii of gyration	i _p	cm	1.14	1.53	1.92
	i _{p,M}	cm	1.61	2.11	3.14
Warping radius of gyration	i _{ω,M}	cm	0.12	0.15	0.78
Torsional constant	J	cm ⁴	0.0015	0.0045	0.01
Secondary torsional constant	J _s	cm ⁴	0.18	0.47	2.21
Location of the shear center	y _{M,0}	cm	1.78	2.67	2.02
	z _{M,0}	cm	-0.06	-0.07	4.12
	y _M	cm	0.56	0.74	0.00
	z _M	cm	-0.99	-1.26	2.48
Warping constants	I _{ω,C}	cm ⁶	0.54	2.86	31.61
	I _{ω,M}	cm ⁶	0.02	0.09	9.04
Section moduli	S _{y,max}	cm ³	0.25	0.57	1.78
	S _{y,min}	cm ³	-0.41	-1.00	-1.08
	S _{z,max}	cm ³	0.45	1.03	1.73
	S _{z,min}	cm ³	-0.16	-0.36	-1.73
Torsional section modulus	S _t	cm ³	0.01	0.03	0.06
Max. plastic bending moment	M _{pl,y,k}	kNm	NPA	NPA	NPA
	M _{pl,z,k}	kNm	NPA	NPA	NPA
Max. plastic section moduli	Z _y	cm ³	NPA	NPA	NPA
	Z _z	cm ³	NPA	NPA	NPA
Plastic shear areas	A _{pl,y}	cm ²	NPA	NPA	NPA
	A _{pl,z}	cm ²	NPA	NPA	NPA
Area bisecting axis position	f _{y,0}	cm	NPA	NPA	NPA
	f _{z,0}	cm	NPA	NPA	NPA
Plastic shear forces	V _{pl,y,k}	kN	NPA	NPA	NPA
	V _{pl,z,k}	kN	NPA	NPA	NPA
Plastic axial forces	N _{pl,k}	kN	NPA	NPA	NPA
Buckling curves	BC _y	-	c	c	c
	BC _z	-	c	c	c

HILTI installation channels of MT System

Performances
Cross section characteristic of channels MT-10, MT-15,
MT-15 OC, MT-20 and MT-20 OC

Annex C1
of European
Technical Assessment
ETA-21/0414

Table C2. Properties of the cross section of channels MT-30 S, MT-30, MT-30 S OC, MT-30 OC, MT-40 T, MT-40 T OC, MT-40 S, MT-40, MT-40 S OC and MT-40 OC

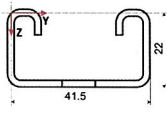
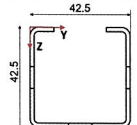
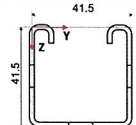
Description	Symbol	Unit	MT-30 S / MT-30 / MT-30 S OC / MT-30 OC	MT-40 T / MT-40 T OC	MT-40 S / MT-40 / MT-40 S OC / MT-40 OC
Cross section (dimensions in mm)	-	-			
Classification cross section in accordance with EN 1993-1-1	-	-	3	3	3
Cross section areas	A	cm ²	1.81	1.76	2.15
	A _{tot}	cm ²	1.81	1.76	2.15
Shear areas	A _y	cm ²	0.25	0.43	0.24
	A _z	cm ²	0.62	1.30	1.39
Centroid position	y _{C,0}	cm	2.02	2.13	2.02
	z _{C,0}	cm	1.10	2.30	2.07
Moments of inertia	I _y	cm ⁴	1.22	4.85	5.80
	I _z	cm ⁴	5.22	5.73	6.61
Polar moments of inertia	I _p	cm ⁴	6.43	10.58	12.41
	I _{p,M}	cm ⁴	16.42	40.93	55.83
Radii of gyration	i _y	cm	0.82	1.66	1.64
	i _z	cm	1.70	1.80	1.75
Polar radii of gyration	i _p	cm	1.89	2.45	2.40
	i _{p,M}	cm	3.01	4.82	5.10
Warping radius of gyration	i _{ω,M}	cm	0.72	0.80	0.83
Torsional constant	J	cm ⁴	0.02	0.02	0.03
Secondary torsional constant	J _s	cm ⁴	3.83	7.78	8.74
Location of the shear center	y _{M,0}	cm	2.02	2.13	2.02
	z _{M,0}	cm	3.45	6.45	6.57
	y _M	cm	0.00	0.00	0.00
	z _M	cm	2.35	4.15	4.49
Warping constants	I _{ω,C}	cm ⁶	37.34	125.13	172.04
	I _{ω,M}	cm ⁶	8.52	26.38	38.40
Section moduli	S _{y,max}	cm ³	1.11	2.49	2.79
	S _{y,min}	cm ³	-1.01	-2.11	-2.67
	S _{z,max}	cm ³	2.45	2.69	3.11
	S _{z,min}	cm ³	-2.45	-2.69	-3.11
Torsional section modulus	S _t	cm ³	0.08	0.12	0.13
Max. plastic bending moment	M _{pl,y,k}	kNm	NPA	NPA	NPA
	M _{pl,z,k}	kNm	NPA	NPA	NPA
Max. plastic section moduli	Z _y	cm ³	NPA	NPA	NPA
	Z _z	cm ³	NPA	NPA	NPA
Plastic shear areas	A _{pl,y}	cm ²	NPA	NPA	NPA
	A _{pl,z}	cm ²	NPA	NPA	NPA
Area bisecting axis position	f _{y,0}	cm	NPA	NPA	NPA
	f _{z,0}	cm	NPA	NPA	NPA
Plastic shear forces	V _{pl,y,k}	kN	NPA	NPA	NPA
	V _{pl,z,k}	kN	NPA	NPA	NPA
Plastic axial forces	N _{pl,k}	kN	NPA	NPA	NPA
Buckling curves	BC _y	-	c	c	c
	BC _z	-	c	c	c

HILTI installation channels of MT System

Performances

Cross section characteristic of channels MT-30 S, MT-30, MT-30 S OC, MT-30 OC, MT-40 T, MT-40 T OC, MT-40 S, MT-40, MT-40 S OC and MT-40 OC

Annex C2

of European
Technical Assessment
ETA-21/0414

Table C3. Properties of the cross section of channels MT-50 S, MT-50, MT-50 S OC, MT-50 OC, MT-60 S, MT-60, MT-60 S OC, MT-60 OC, MT-70 S OC and MT-70 OC

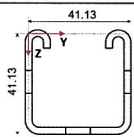
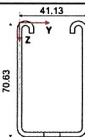
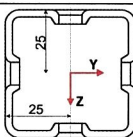
Description	Symbol	Unit	MT-50 S / MT-50 / MT-50 S OC / MT-50 OC	MT-60 S / MT-60 / MT-60 S OC / MT-60 OC	MT-70 S OC / MT-70 OC
Cross section (dimensions in mm)	-	-			
Classification cross section in accordance with EN 1993-1-1	-	-	3	4	3
Cross section areas	A	cm ²	2.77	4.70	4.32
	A _{tot}	cm ²	2.77	4.70	4.32
Shear areas	A _y	cm ²	0.32	0.30	1.78
	A _z	cm ²	1.67	3.22	1.78
Centroid position	y _{C,0}	cm	1.99	1.99	0.00
	z _{C,0}	cm	2.07	3.66	0.00
Moments of inertia	I _y	cm ⁴	7.07	26.81	15.96
	I _z	cm ⁴	8.30	16.04	15.96
Polar moments of inertia	I _p	cm ⁴	15.36	42.85	31.93
	I _{p,M}	cm ⁴	66.91	267.95	31.93
Radii of gyration	i _y	cm	1.60	2.39	1.92
	i _z	cm	1.73	1.85	1.92
Polar radii of gyration	i _p	cm	2.35	3.02	2.72
	i _{p,M}	cm	4.91	7.55	2.72
Warping radius of gyration	i _{ω,M}	mm	0.78	0.74	0.25
Torsional constant	J	cm ⁴	0.05	0.09	19.95
Secondary torsional constant	J _s	cm ⁴	9.76	17.64	3.12
Location of the shear center	y _{M,0}	cm	1.99	1.99	0.00
	z _{M,0}	cm	6.38	10.59	0.00
	y _M	cm	0.00	0.00	0.00
	z _M	cm	4.31	6.92	0.00
Warping constants	I _{ω,C}	cm ⁶	195.50	914.85	2.04
	I _{ω,M}	cm ⁶	41.10	144.98	2.04
Section moduli	S _{y,max}	cm ³	3.46	7.89	6.39
	S _{y,min}	cm ³	-3.21	-7.09	-6.39
	S _{z,max}	cm ³	3.90	7.55	6.39
	S _{z,min}	cm ³	-3.90	-7.55	-6.39
Torsional section modulus	S _t	cm ³	0.17	0.31	7.62
Max. plastic bending moment	M _{pl,y,k}	kNm	NPA	NPA	NPA
	M _{pl,z,k}	kNm	NPA	NPA	NPA
Max. plastic section moduli	Z _y	cm ³	NPA	NPA	NPA
	Z _z	cm ³	NPA	NPA	NPA
Plastic shear areas	A _{pl,y}	cm ²	NPA	NPA	NPA
	A _{pl,z}	cm ²	NPA	NPA	NPA
Area bisecting axis position	f _{y,0}	cm	NPA	NPA	NPA
	f _{z,0}	cm	NPA	NPA	NPA
Plastic shear forces	V _{pl,y,k}	kN	NPA	NPA	NPA
	V _{pl,z,k}	kN	NPA	NPA	NPA
Plastic axial forces	N _{pl,k}	kN	NPA	NPA	NPA
Buckling curves	BC _y	-	c	c	c
	BC _z	-	c	c	c

HILTI installation channels of MT System

Performances

Cross section characteristic of channels MT-50 S, MT-50, MT-50 S OC, MT-50 OC, MT-60 S, MT-60, MT-60 S OC, MT-60 OC, MT-70 S OC and MT-70 OC

Annex C3

of European
Technical Assessment
ETA-21/0414

Table C4. Properties of the cross section of channels MT-80 S OC, MT-80 OC, MT-90 S OC, MT-90 OC, MT-100 S OC and MT-100 OC

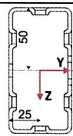
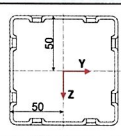
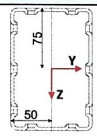
Description	Symbol	Unit	MT-80 S OC / MT-80 OC	MT-90 S OC / MT-90 OC	MT-100 S OC / MT-100 OC
Cross section (dimensions in mm)	-	-			
Classification cross section in accordance with EN 1993-1-1	-	-	3	3	3
Cross section areas	A	cm ²	5.96	9.80	15.63
	A _{tot}	cm ²	5.96	9.80	15.63
Shear areas	A _y	cm ²	1.78	3.94	4.49
	A _z	cm ²	4.62	3.94	8.27
Centroid position	y _{C,0}	cm	0.00	0.00	0.00
	z _{C,0}	cm	0.00	0.00	0.00
Moments of inertia	I _y	cm ⁴	88.39	151.49	490.02
	I _z	cm ⁴	24.61	151.49	262.25
Polar moments of inertia	I _p	cm ⁴	113.00	302.97	752.27
	I _{p,M}	cm ⁴	113.00	302.97	752.27
Radii of gyration	i _y	cm	3.85	3.93	5.60
	i _z	cm	2.03	3.93	4.10
Polar radii of gyration	i _p	cm	4.36	5.56	6.94
	i _{p,M}	cm	4.36	5.56	6.94
Warping radius of gyration	i _{ω,M}	cm	0.60	0.23	0.63
Torsional constant	J	cm ⁴	67.13	204.70	475.42
Secondary torsional constant	J _s	cm ⁴	9.24	22.23	23.94
Location of the shear center	y _{M,0}	cm	0.00	0.00	0.00
	z _{M,0}	cm	0.00	0.00	0.00
	y _M	cm	0.00	0.00	0.00
	z _M	cm	0.00	0.00	0.00
Warping constants	I _{ω,C}	cm ⁶	40.95	15.47	303.04
	I _{ω,M}	cm ⁶	40.95	15.47	303.04
Section moduli	S _{y,max}	cm ³	17.68	30.30	65.34
	S _{y,min}	cm ³	-17.68	-30.30	-65.34
	S _{z,max}	cm ³	9.84	30.30	52.45
	S _{z,min}	cm ³	-9.84	-30.30	-52.45
Torsional section modulus	S _t	cm ³	16.26	33.99	50.87
Max. plastic bending moment	M _{pl,y,k}	kNm	NPA	NPA	NPA
	M _{pl,z,k}	kNm	NPA	NPA	NPA
Max. plastic section moduli	Z _y	cm ³	NPA	NPA	NPA
	Z _z	cm ³	NPA	NPA	NPA
Plastic shear areas	A _{pl,y}	cm ²	NPA	NPA	NPA
	A _{pl,z}	cm ²	NPA	NPA	NPA
Area bisecting axis position	f _{y,0}	cm	NPA	NPA	NPA
	f _{z,0}	cm	NPA	NPA	NPA
Plastic shear forces	V _{pl,y,k}	kN	NPA	NPA	NPA
	V _{pl,z,k}	kN	NPA	NPA	NPA
Plastic axial forces	N _{pl,k}	kN	NPA	NPA	NPA
Buckling curves	BC _y	-	c	c	c
	BC _z	-	c	c	c

HILTI installation channels of MT System**Performances**

Cross section characteristic of channels MT-80 S OC, MT-80 OC, MT-90 S OC, MT-90 OC, MT-100 S OC and MT-100 OC

Annex C4

of European
Technical Assessment
ETA-21/0414

Table C5. Properties of the cross section of channels MT-40D S, MT-40D, MT-40D S OC and MT-40D OC

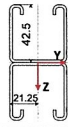
Description	Symbol	Unit	MT-40D S / MT-40D / MT-40D S OC / MT-40D OC
Cross section (dimensions in mm)	-	-	
Classification cross section in accordance with EN 1993-1-1	-	-	3
Cross section areas	A	cm ²	4.31
	A _{tot}	cm ²	4.31
Shear areas	A _y	cm ²	0.47
	A _z	cm ²	1.16
Centroid position	y _{C,0}	cm	0.00
	z _{C,0}	cm	0.00
Moments of inertia	I _y	cm ⁴	30.13
	I _z	cm ⁴	13.22
Polar moments of inertia	I _p	cm ⁴	43.35
	I _{p,M}	cm ⁴	43.35
Radii of gyration	i _y	cm	2.64
	i _z	cm	1.75
Polar radii of gyration	i _p	cm	3.17
	i _{p,M}	cm	3.17
Warping radius of gyration	i _{w,M}	cm	1.89
Torsional constant	J	cm ⁴	0.05
Secondary torsional constant	J _s	cm ⁴	6.79
Location of the shear center	y _{M,0}	cm	0.00
	z _{M,0}	cm	0.00
	y _M	cm	0.00
	z _M	cm	0.00
Warping constants	I _{w,C}	cm ⁶	154.25
	I _{w,M}	cm ⁶	154.25
Section moduli	S _{y,max}	cm ³	7.09
	S _{y,min}	cm ³	-7.09
	S _{z,max}	cm ³	6.22
	S _{z,min}	cm ³	-6.22
Torsional section modulus	S _t	cm ³	0.26
Max. plastic bending moment	M _{pl,y,k}	kNm	NPA
	M _{pl,z,k}	kNm	NPA
Max. plastic section moduli	Z _y	cm ³	NPA
	Z _z	cm ³	NPA
Plastic shear areas	A _{pl,y}	cm ²	NPA
	A _{pl,z}	cm ²	NPA
Area bisecting axis position	f _{y,0}	cm	NPA
	f _{z,0}	cm	NPA
Plastic shear forces	V _{pl,y,k}	kN	NPA
	V _{pl,z,k}	kN	NPA
Plastic axial forces	N _{pl,k}	kN	NPA
Buckling curves	BC _y	-	c
	BC _z	-	c

HILTI installation channels of MT System

Performances
Cross section characteristic of channels MT-40D S, MT-40D,
MT-40D S OC and MT-40D OC

Annex C5
of European
Technical Assessment
ETA-21/0414