

# HILTI

## Hilti X-BT Threaded Fastener Specification

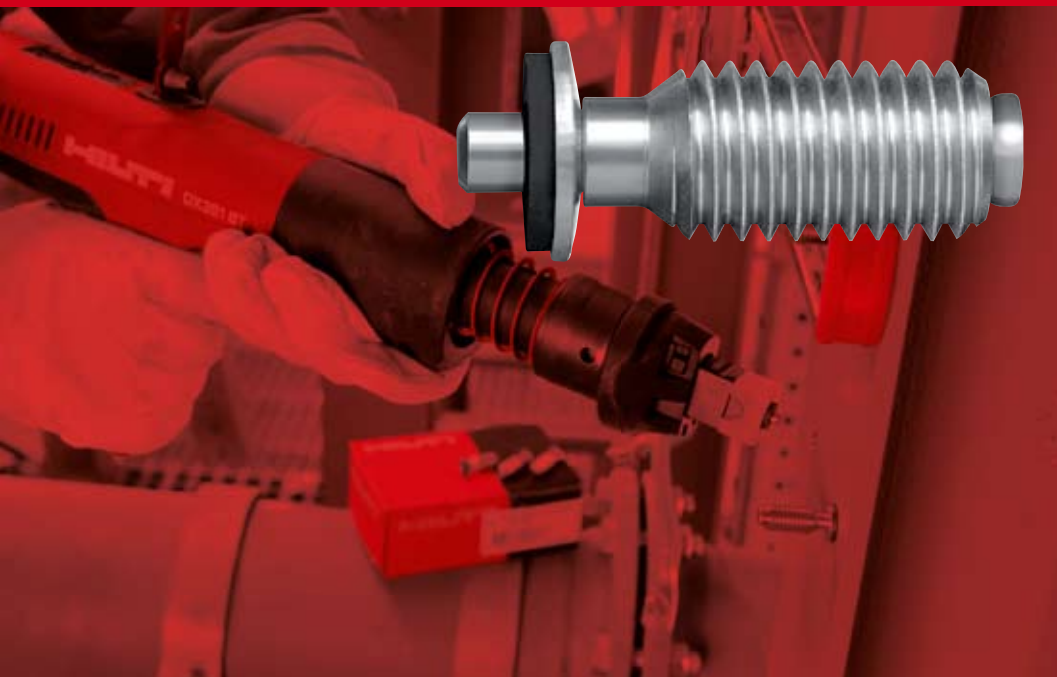

December 2010

<b>1. The X-BT system</b>	<b>page 4</b>
<b>2. Applications</b>	<b>page 5</b>
2.1 Grating fastening system	5
2.2 X-BT and MQ installation channel system	7
2.3 Fastening instrumentation, junction boxes and lighting	8
2.4 Fastening cable/conduit connectors	9
2.5 Fastening cable tray supports	9
2.6 X-BT for fastening and connecting earthing devices	10
<b>3. Technical data</b>	<b>page 11</b>
3.1 Product data	11
3.1.1 Material specifications	11
3.1.2 Fastening tool	11
3.1.3 Approvals	11
3.2 Load data	12
3.3 Application requirements and limits	13
3.3.1 Thickness of fastened material	
3.3.2 Spacing and edge distance	
3.3.3 Application limit/thickness of base material	
3.3.4 Fastener selection	
3.3.5 Cartridge selection and tool energy setting	
3.3.6 Installation details	14
3.3.7 Fastening quality assurance	
<b>4. Method statement</b>	<b>page 15</b>
4.1 Instructions for use	
4.1 DX 351 BT/G tool maintenance	16

<b>5. Performance</b> (technical reports)	<b>page 17</b>
5.1 Nomenclature and symbols / design concepts	17-18
5.2 Static capacity of the X-BT threaded stud	19
5.2.1 Tensile load deformation behavior of the X-BT threaded stud fastenings	19
5.2.2 Pullout strength of X-BT threaded stud fastenings	20
5.2.3 Shear strength of X-BT threaded stud fastenings	21
5.2.4 Effect of edge distance/spacing on pull-out strength of X-BT fastenings	22-23
5.2.5 Holding mechanisms X-BT threaded stud fastenings	24
5.3 Corrosion resistance	25
5.3.1 X-BT threaded stud fastening corrosion data	25-26
5.3.2 Contact corrosion – X-BT stainless steel stud in carbon steel	27
5.3.3 Corrosion data from field tests at Helgoland island (North Sea)	28
5.4 Effect of X-BT threaded stud fastenings on steel base material	29-30
5.5 Vibration effects on X-BT threaded stud fastenings	31
5.6 Temperature resistance of X-BT threaded stud fastenings	32-33
5.7 Threaded stud for fastening earthing/grounding, bonding and lightning protection systems	34
6.7.1 Protective earthing/grounding and bonding	34
6.7.2 External lightning protection	35
5.8 X-BT in stainless steel base material	36
5.9 X-BT under shock loading	37
5.10 X-BT stud in steel with a thickness of less than 8 mm	38
6.10.1 Pull-out capacity in thin steel	38
6.10.2 Shear load capacity in thin steel	38-39
6.10.3 X-BT electrical conductivity in thin steel	39
5.11 Chemical resistance of SN 12 sealing washer	40
5.12 Material safety data sheet of SN 12 sealing washer	41-47
<b>6. Approvals</b>	<b>page 48</b>
5.1 American Bureau of Shipping (ABS) (2)	48
5.2 Lloyd's Register	52
5.3 Germanischer Lloyd (GL)	54
5.4 Det Norske Veritas (DNV)	56
5.5 ICC-ES	60
<b>7. Customer testimonials</b>	<b>page 65</b>

## 1. The X-BT system

### Simplified fastening to steel - system features and benefits

#### No rework.

Stud welding or through-bolting, for example, may require reworking of the protective surface coating. With X-BT, the stud is set into a small pre-drilled hole and the drill entry point is then completely sealed by the stud washer during setting.



Rework

#### Simple and fast.

A minimal amount of training is all that's required for a user to be able to drive more than 100 studs per hour.



Corrosion

#### High corrosion resistance.

X-BT studs are made of high grade A4 (316 SS) stainless steel, making them the right choice for corrosive environments.

#### High loading and pull-out values.

X-BT delivers performance comparable to methods such as stud welding.

#### Fasten to all steel shapes.

Unlike clamps, which are limited by the configuration of the base steel, the X-BT is ideal for use on tubulars, channel sections, wide flanges and angles.



Loosening

#### Fasten to all steel grades.

In addition to fastening to standard construction steel, the X-BT can also be used to fasten to high strength and thick steel.

#### Portable and safe.

The fastening tool's self-contained energy source eliminates the need for electrical cords and heavy welding equipment.

#### No through-penetration.

The special process of drilling and driving results in secure fastening of the stud without through-penetrating of the base material.



Through-penetration

## 2. Applications

### 2.1 Grating fastening system

(X-BT M8-15-6 SN12-R and X-FCM-R)

An all stainless steel fastening system designed for attaching metal and fiber-glass grating to coated steel and/or high-strength steel

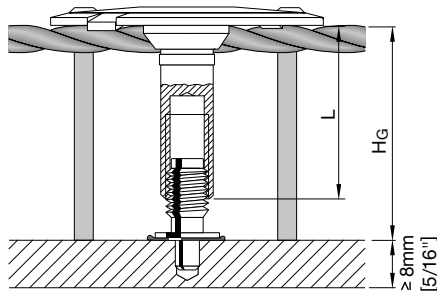
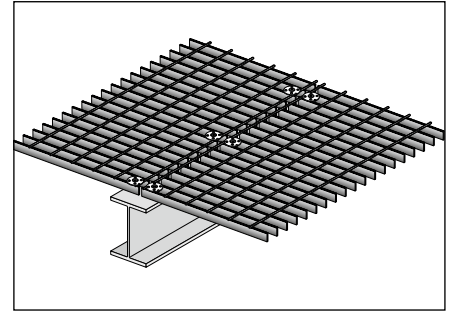

X-FCM-R grating disc

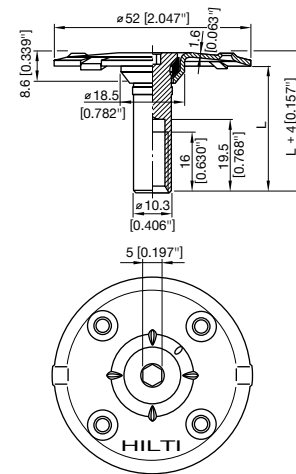

**Important:** For safety reasons (shear load), the X-FCM-R system must not be used for fastening of grating used for vehicle traffic.

#### X-SEA-R 30 M8 extension adaptor

For use with X-FCM-R grating fasteners for fastening of grating with a height in excess of 50 mm/1.97 in.

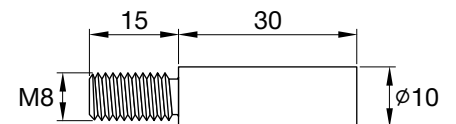
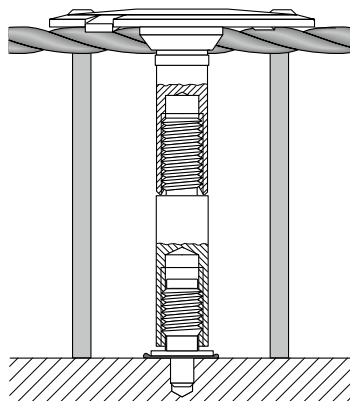

Fastener selection

Designation	L (mm/in.)	Grating height, HG, range (mm/in.)	Grating height with X-SEA-R 30 M8
X-FCM-R 25/30	23/0.91	25-30/0.98-1.18	55-60/2.16-2.36
X-FCM-R 1"-1¼"	27/1.06	29-34/1.14-1.34	59-64/2.32-2.52
X-FCM-R 35/40	33/1.30	35-40/1.38-1.57	65-70/2.56-2.75
X-FCM-R 45/50	43/1.69	45-50/1.77-1.97	75-80/2.91-3.15

## Installation instructions

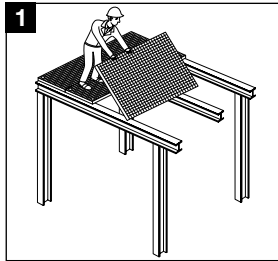

1 Lay grating section in final position.

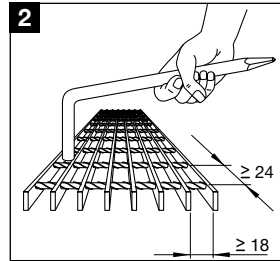

2 Expand grating openings if necessary.

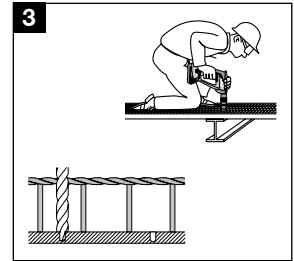

3 Pre-drill with **TX-BT 4/7** step shank drill bit.

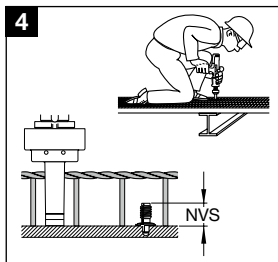

4 Drive fastener only with **DX 351 BT G** tool and 6.8/11M brown cartridge.

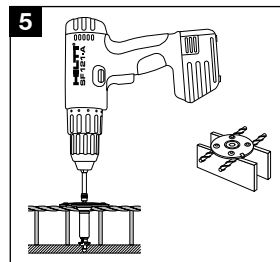

5 Tighten **X-FCM-R** with 5 mm Allen-type bit.

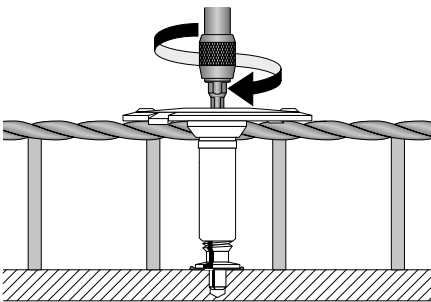

## Installation details

Hand start, then tighten using screwdriver with torque clutch.

Tightening torque: 5–8 Nm [3.7–5.9 ft-lb]

Hilti screwdriver	Torque setting
<b>SF 121-A</b>	11
<b>SF 150-A</b>	9
<b>SF 180-A</b>	8
<b>SF 144-A</b>	9
<b>SF 22-A</b>	9

## 2.2 X-BT and MQ installation channel system

### MQ installation channel on coated steel (electrical installation and small-bore piping)

Note: In case of applied shear load, the X-BT must be placed according to illustration (end of slotted hole)

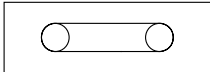
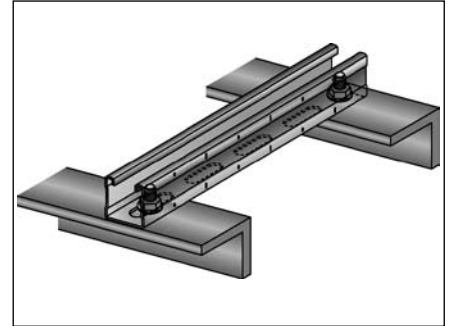

Two **X-BT** studs in one slotted hole

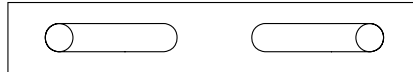

One **X-BT** stud in each slotted hole

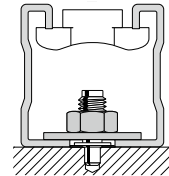

### Fastening MQ brackets and bases for raised floor

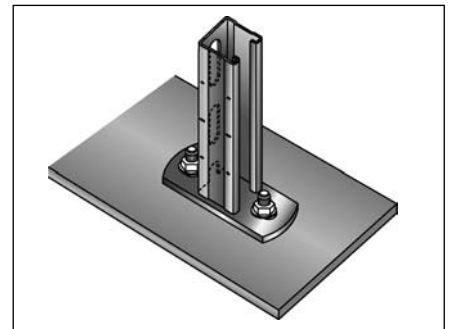

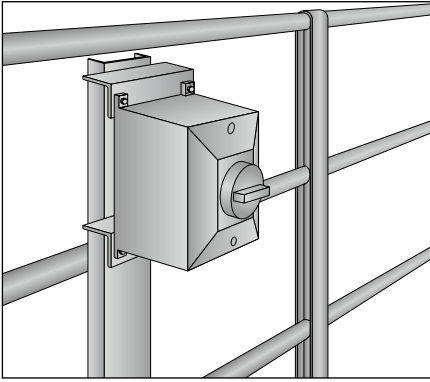

## 2.3 Fastening instrumentation, junction boxes and lighting

X-BT stainless steel threaded stud for attaching instrumentation, junction boxes and lighting to coated steel and high-strength steel

### Installation instructions

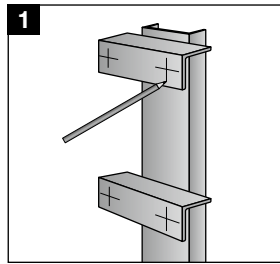

**1**  
Mark location of each fastening.

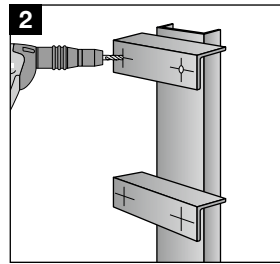

**2**  
Pre-drill with **TX-BT 4/7** step shank drill bit.

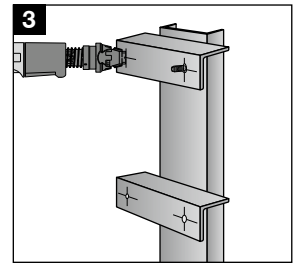

**3**  
Drive **X-BT-R** studs with **DX 351 BT** tool and **X-BT** cartridge.

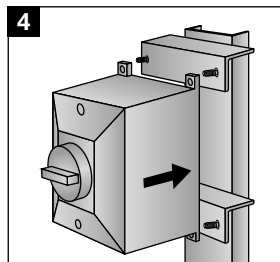

**4**  
Position unit on studs and hold in place.  
Fit washers and hand-tighten nuts.

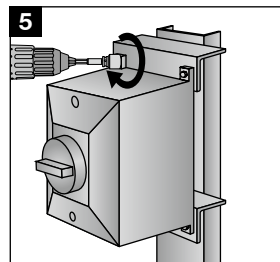

**5**  
Tighten using a screwdriver with torque clutch.



## 2.4 Fastening cable/conduit connectors

X-BT threaded stud for cable/conduit connectors.

Stainless steel threaded stud for fastening cable and conduit connectors (T-bars) to coated steel and/or high-strength steel

### Installation instructions

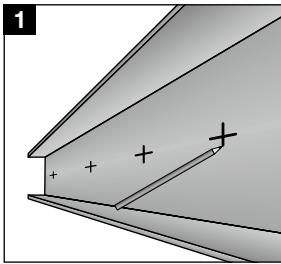

1 Mark location of each fastening.

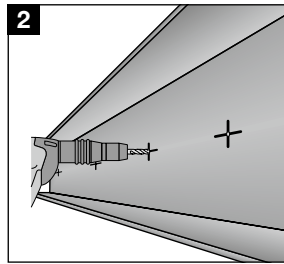

2 Pre-drill with **TX-BT 4/7** step shank drill bit.

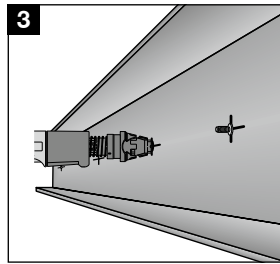

3 Drive fastener only with **DX 351 BT** tool and 6.8/M brown cartridge.

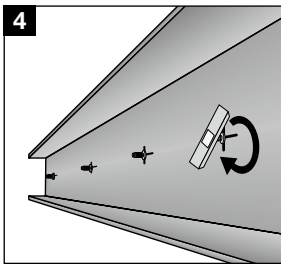

4 Screw on the connector and hand tighten.

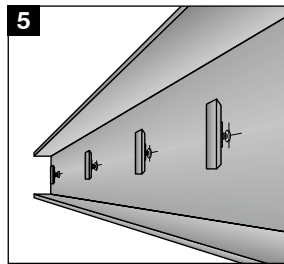

5 Align connectors.

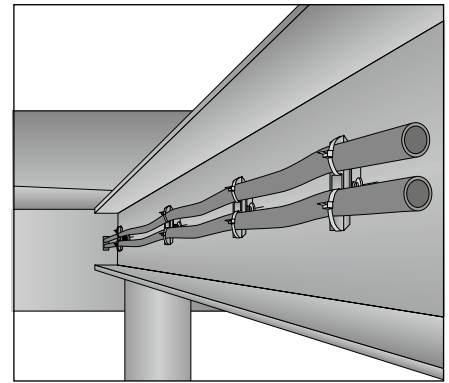

## 2.5 Fastening cable tray supports

X-BT stainless steel stud for fastening cable trays to coated and / or high-strength steel

### Installation instructions

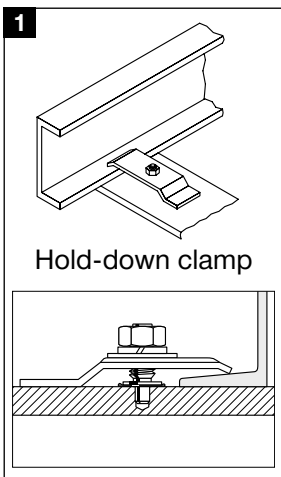

1 Hold-down clamp

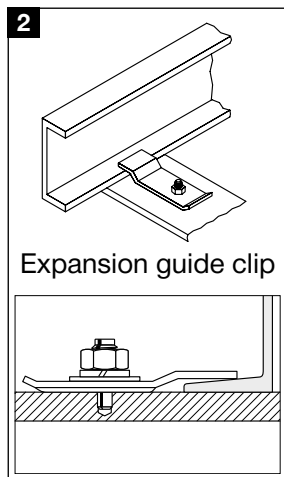

2 Expansion guide clip

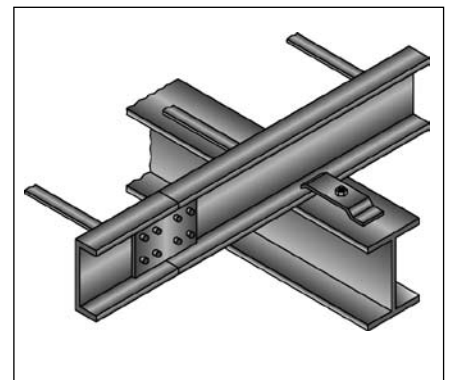

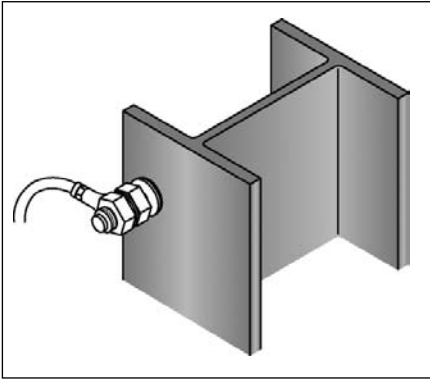

## 2.6 X-BT for grounding and bonding equipment

### Installation instructions

Fasteners

**X-BT M10-24-6 SN12-R**

**X-BT W10-24-6 SN12-R**

**X-BT M6-24-6 SN12-R**

**X-BT W6-24-6 SN12-R**

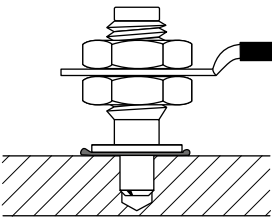

Single-point connection

### Protective earthing/grounding circuits

(According to EN 60439-1, EN 60204-1, IEC 60947-7-2)

Maximum connected cable size  $\leq 10 \text{ mm}^2$  copper AWG 8

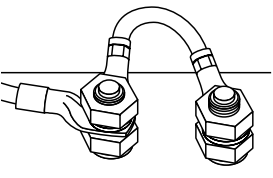

Double-point connection

Maximum connected cable size  $\leq 16 \text{ mm}^2$  copper AWG 6

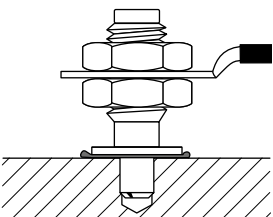

### External lightning protection systems

(According to EN 50164-1)

Test class = N,  $I_{\text{max}} = 50 \text{ kA}$ , Time =  $t_d \leq 2 \text{ ms}$

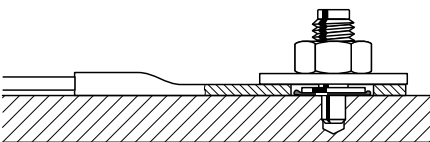

Test class = H,  $I_{\text{max}} = 100 \text{ kA}$ , Time =  $t_d \leq 2 \text{ ms}$

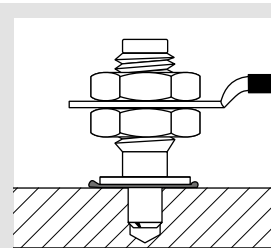

Hold the lower nut with a spanner whilst tightening the second nut to a torque of about 20 Nm.

### 3. Technical data

#### 3.1 Product data

##### 3.1.1 Material specifications

① Shank:	CR500 (CrNiMo alloy) S31803 (1.4462) N 08926 (HCR, 1.4529) <sup>1)</sup>	equivalent to A4 / AISI grade 316 material available on request
② Threaded sleeve:	S 31600 (X2CrNiMo 17132)	
③ SN12-R washers:	S 31635 (X5CrNiMo 17 - 12 - 2 + 2H)	
④ Sealing washers:	Elastomer, black, resistant to UV, salt water, water, ozone, oils, etc.	
⑤ Guide washer:	plastic	

Designation according to Unified Numbering System (UNS)

<sup>1)</sup> For high corrosion resistance HCR material inquire at Hilti.

##### 3.1.2 Fastening tool

DX 351-BT / BTG, see fastener selection in section 3.3.5.

##### 3.1.3 Approvals

ABS, DNV, GL, LR, ICC ESR-2347, UL



The X-BT fastening systems holds several Type Approvals internationally valid for the ship-building and off-shore industry. These approvals are issued by international classification bodies relevant for these industries.

These bodies are:

- ABS – American Bureau of Shipping
- DNV – Det Norske Veritas
- GL – Germanischer Lloyd
- LR – Lloyds Register

The ICC-ES approval ESR-2347 covers application of the X-BT in building construction. ESR-2347 is valid in the U.S. and allows the use of the X-BT in compliance with the 2009 International Building Code (2009 IBC).

The UL-listing (File E257069) addresses the use of X-BT as grounding and bonding equipment.

Chapter 6 summarizes print-outs of the Type Approvals as well as the ESR-2347. These printouts allow for a general survey of the scope of the approvals, being valid end of December 2010.

As approvals are subject to continuous changes, which take code developments (like ESR-2347), update of the product portfolio as well as the implementation of new research results into account (see chapter 5.4). Current approvals can be downloaded from Hilti website or from the websites of most Certification Bodies.

X-BT W10-24-6 SN12-R  
X-BT M10-24-6 SN12-R

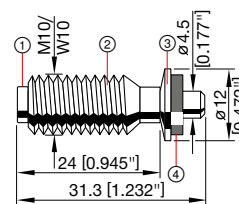

X-BT M8-15-6 SN12-R

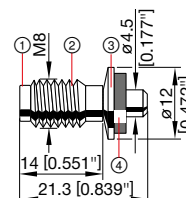

X-BT W10-24-6-R  
X-BT M10-24-6-R

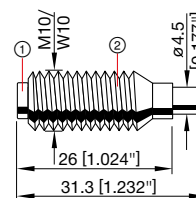

X-BT M8-15-6-R

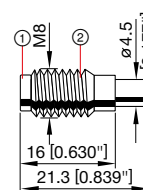

X-BT W6-24-6 SN12-R  
X-BT M6-24-6 SN12-R

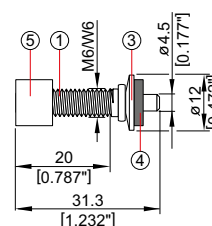

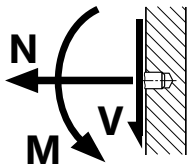

### 3.2 Load data

#### Recommended loads

Steel grade: Europe, USA	S235, A36	S355, grade 50 and stronger steel
Tension, <b>N<sub>rec</sub></b> [kN/lb]	1.8 / 405	2.3 / 517
Shear, <b>V<sub>rec</sub></b> [kN/lb]	2.6 / 584	3.4 / 764
Moment, <b>M<sub>rec</sub></b> [Nm/lb]	8.2 / 6	8.2 / 6
Torque, <b>T<sub>rec</sub></b> [Nm/lb]	8 / 5.9	8 / 5.9

Example:

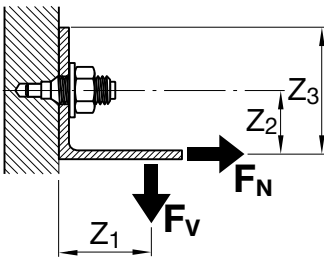

#### Conditions for recommended loads

- Global factor of safety for static pull-out > 3 (based on 5% fractile value)
- Minimum edge distance = 6 mm [1/4"].
- Effect of base metal vibration and stress considered.
- Redundancy (multiple fastening) must be provided.
- The recommended loads in the table refer to the resistance of the individual fastening and may not be the same as the loads  $F_N$  and  $F_V$  acting on the fastened part.

**Note:** If relevant, prying forces need to be considered in design, see example. Moment acting on fastener shank only in case of a gap between base and fastened material.

#### Cyclic loading

- Anchorage of X-BT threaded stud in steel base material is not affected by cyclic loading.
- Fatigue strength is governed by fracture of the shank. The characteristic number of loads cycles  $N_K$  at 1.8 kN amounts to approximately 0.5 million. Ask Hilti for more detailed test data if high cyclic loading has to be considered in the design.

### 3.3 Application requirements and limits

#### 3.3.1 Thickness of fastened material

- X-BT M8:  $2.0 \leq t_f \leq 7 \text{ mm}$
- X-BT M10 / X-BT W10:  $2.0 \leq t_f \leq 15 \text{ mm}$
- X-BT M6 / X-BT W6:  $1.0 \leq t_f \leq 14 \text{ mm}$

**Note**

For X-BT with SN 12R sealing washer  $t_f \geq 2.0 \text{ mm}$   
 For X-BT M6 / W6 with SN 12R sealing washer  $t_f \geq 1.0 \text{ mm}$

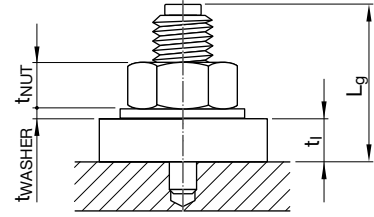

#### 3.3.2 Spacing and edge distances

Spacing:  $\geq 15 \text{ mm}$

Edge distance:  $\geq 6 \text{ mm}$

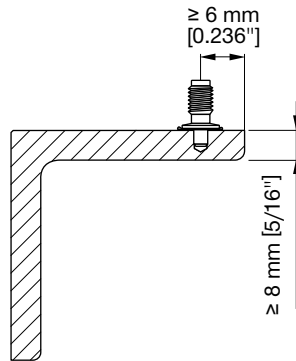
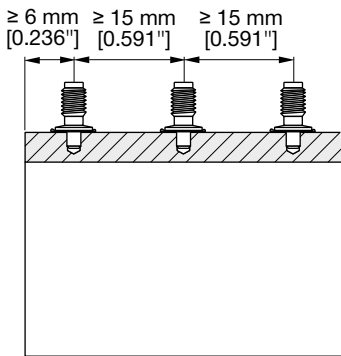

#### 3.3.3 Application limit/thickness of base material

$t_{fl} \geq 8 \text{ mm [5/16"]}$  → No through-penetration. No limits with regard to steel strength.

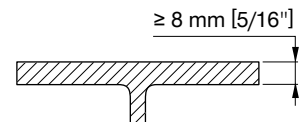

#### 3.3.4 Fastener selection

Designation	Item no.	Tool
		Designation
X-BT M8-15-6 SN12-R	377074	DX 351-BTG
X-BT M10-24-6 SN12-R	377078	DX 351-BT
X-BT W10-24-6 SN12-R	377076	DX 351-BT
X-BT M8 without washer	377073	DX 351-BTG
X-BT M10 without washer	377077	DX 351-BT
X-BT W10 without washer	377075	DX 351-BT
X-BT M6-24-6 SN12-R	432266	DX 351-BT
X-BT W6-24-6 SN12-R	432267	DX 351-BT

For high corrosion resistance HCR material inquire at Hilti.

#### 3.3.5 Cartridge selection and tool power setting

##### 6.8/11 M high-precision brown cartridge

Fine adjustment by installation tests on site

### 3.3.6 Installation details

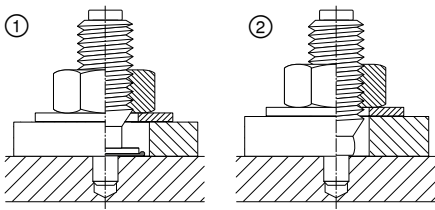

① X-BT with washer  
 Fastened material hole diameter  $\geq 13$  mm

② X-BT without washer  
 Fastened material hole diameter  $\geq 11$  mm for X-BT M/W10  
 $\geq 9$  mm for X-BT M8

#### X-BT M6 / X-BT W6

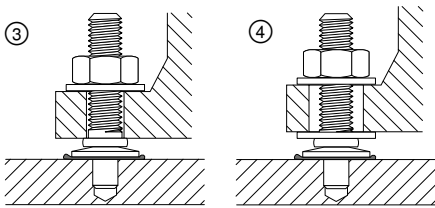

③ Fastened material with pre-drilled hole diameter  $< 7$  mm

④ Fastened material with pre-drilled hole diameter  $\geq 7$  mm + washer



Pre-drill until the bit shoulder grinds a shiny ring (to ensure proper drilling depth).

#### Before fastener installation

The drilled hole must be clear of liquids and debris. The area around the drilled hole must be free from liquids and debris.

Tightening torque, **Trec**  $\leq 8$ Nm [5.9 ft-lb]!

Hilti screwdriver	Torque setting
SF 121-A	11
SF 150-A	9
SF 180-A	8
SF 144-A	9
SF 22-A	9

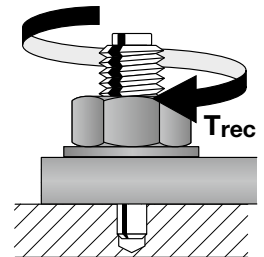

### 3.3.7 Fastening quality assurance

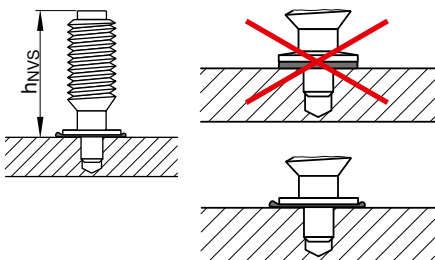

#### Fastening inspection

X-BT M8  
 h<sub>NVS</sub> = 15.7–16.8 mm

X-BT M10 / X-BT W10 and X-BT M6 / X-BT W6  
 h<sub>NVS</sub> = 25.7–26.8 mm

## 4. Method statement

### 4.1 Instructions for use

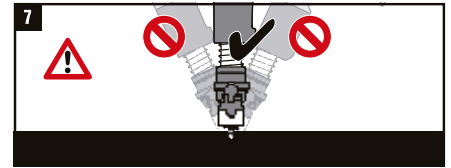
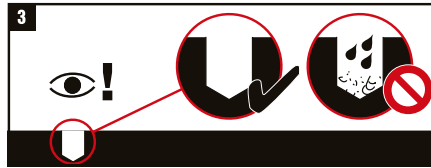
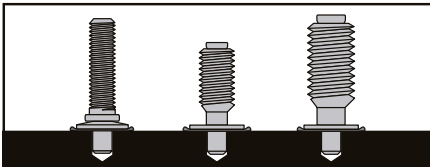

X-BT M6-24-6 SN12-R	DX 351 BT (M)	TX-BT 4/7-80
X-BT M10-24-6 SN12-R	DX 351 BT (W)	
X-BT W6-24-6 SN12-R	DX 351 BT (W)	TX-BT 4/7-110
X-BT W10-24-6 SN12-R	DX 351 BT (W)	
X-BT M8-15-6 SN12-R	DX 351 BTG	

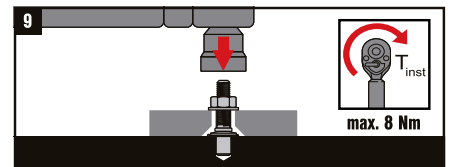
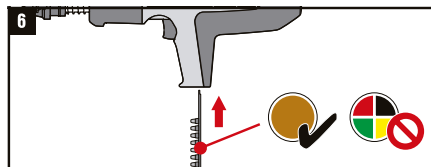
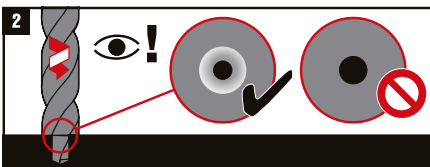
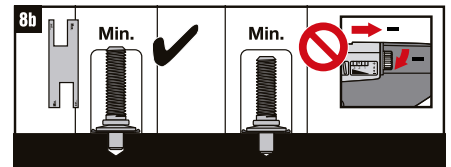
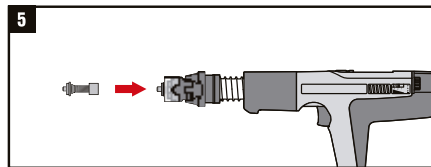
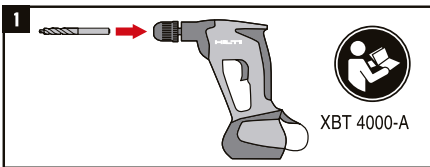
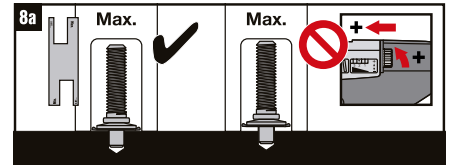
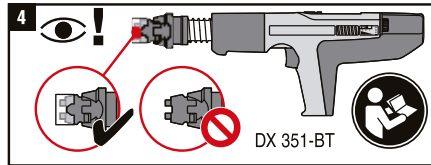

## 4.2 DX 351 BT/G tool maintenance

Service the tool whenever:

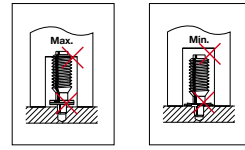
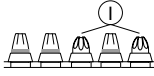

I. a cartridge misfires or

II. driving depth is inconsistent

### Disassembly

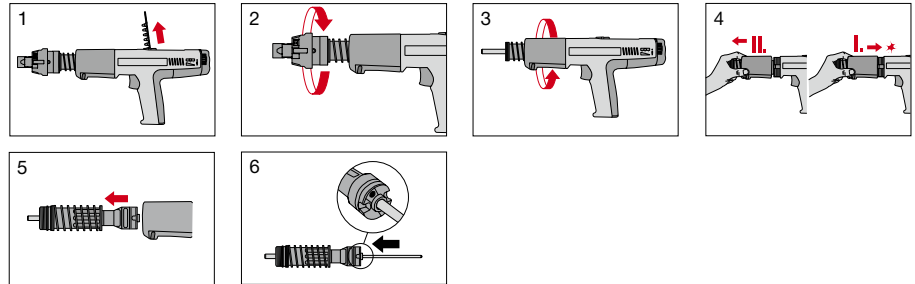

### Check

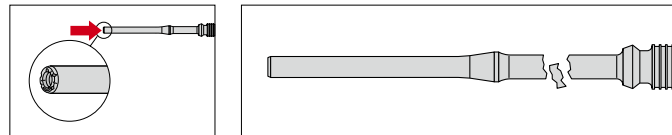

### Cleaning

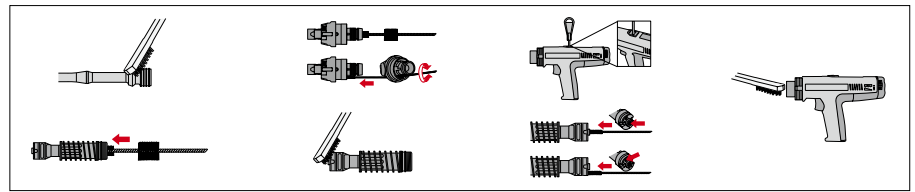

### Assembly

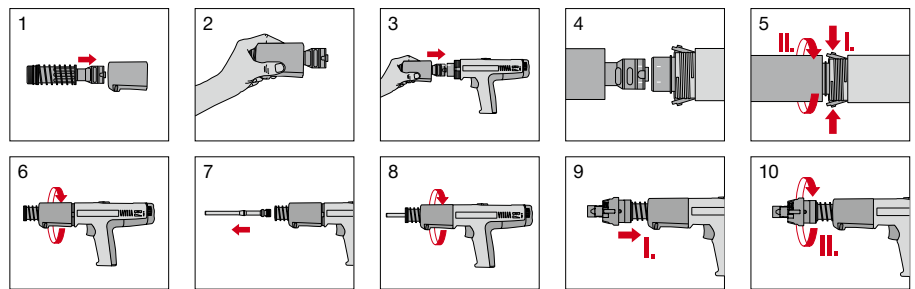

Lubricate your tools regularly with Hilti spray!



## 5. Performance (technical reports)

### 5.1 Nomenclature and symbols, design concepts

The symbols and nomenclature used in the technical data are listed below.

#### Fastener test data and performance

<b>N</b> and <b>V</b>	Tensile and shear forces in a general sense
<b>F</b>	Combined force (resulting from <b>N</b> and <b>V</b> ) in a general sense
<b>N<sub>S</sub></b> and <b>V<sub>S</sub></b>	Tensile and shear forces acting on a fastening in a design calculation
<b>F<sub>S</sub></b>	Combined force (resulting from <b>N<sub>S</sub></b> and <b>V<sub>S</sub></b> ) in a design calculation
<b>N<sub>U</sub></b> and <b>V<sub>U</sub></b>	Ultimate tensile and shear forces that cause failure of the fastening, statistically, the reading for one specimen
<b>N<sub>U,m</sub></b> and <b>V<sub>U,m</sub></b>	Average ultimate tensile and shear forces that cause failure of the fastening, statistically, the average for a sample of several specimens
<b>S</b>	The standard deviation of the sample
<b>N<sub>RK</sub></b> and <b>V<sub>RK</sub></b>	Characteristic tensile and shear resistance of the fastening, statistically, the 5 % fractile. For example, the characteristic strength of a fastening whose ultimate strength can be described by a standard Gauss type distribution is calculated by: <b>N<sub>RK</sub> = N<sub>U,m</sub> - k x S</b> where <b>k</b> is a function of the sample size, <b>n</b> and the desired confidence interval.
<b>N<sub>rec</sub></b> and <b>V<sub>rec</sub></b>	Recommended maximum tensile and shear loads for the fastener shank: <b>N<sub>rec</sub> = <math>\frac{N_{RK}}{\nu}</math></b> and <b>V<sub>rec</sub> = <math>\frac{V_{RK}}{\nu}</math></b> where $\nu$ is the overall factor of safety
<b>M<sub>rec</sub></b>	Recommended working moment for the fastener shank <b>M<sub>rec</sub> = <math>\frac{M_{RK}}{\nu}</math></b> where <b>M<sub>RK</sub></b> is the characteristic moment resistance of the fastener shank and $\nu$ is an overall factory of safety. Unless otherwise stated on the product data sheets, the <b>M<sub>rec</sub></b> values in this manual include a safety factor of "2" for static loading.

#### Fastening details

<b>h<sub>ET</sub></b>	Penetration of the fastener point below the surface of the base material
<b>h<sub>NVS</sub></b>	Nail head standoff above the surface fastened into (with nails, this is the surface of the fastened material, with threaded studs, the surface of the base material).
<b>t<sub>ii</sub></b>	Thickness of the base material
<b>t<sub>i</sub></b>	Thickness of the fastened material
<b>Σ t<sub>i</sub></b>	Total thickness of the fastened material (where more than one layer is fastened)

#### Characteristics of steel and other metals

<b>f<sub>y</sub></b> and <b>f<sub>u</sub></b>	Yield strength and ultimate strength of metals (in N/mm <sup>2</sup> or MPa)
---	--

## Design concepts

The recommended working loads ( $N_{\text{rec}}$  and  $V_{\text{rec}}$ ) are suitable for use in typical working load designs.

If the X-BT has to be designed in accordance with a partial safety concept, the recommended loads have to be multiplied by the global safety factor, applicable to the respective design concept, to calculate the characteristic loads  $N_{\text{RK}}$  and  $V_{\text{RK}}$ . E.g. in case of a design in compliance with the Eurocodes, the global safety factor would be 2.

### Working load concept

$$N_{\text{S}} \leq N_{\text{rec}} = \frac{N_{\text{RK}}}{\nu}$$

where  $\nu$  is an overall factor of safety including allowance for:

- errors in estimation of load
- deviations in material and workmanship

and  $N_{\text{S}}$  is, in general, a characteristic acting load.

$$N_{\text{S}} \cong N_{\text{Sk}}$$

### Partial safety concept

$$N_{\text{Sd}} \leq N_{\text{Rd}}$$

$$N_{\text{Sd}} = N_{\text{Sk}} \times \gamma_{\text{F}}$$

$$N_{\text{Rd}} = N_{\text{RK}} / \gamma_{\text{m}}$$

where  $\gamma_{\text{F}}$  is a partial factor of safety to allow for errors in estimation on the acting load.

$\gamma_{\text{m}}$  is a partial factor of safety to allow for deviations in material and workmanship.

## 5.2 Static capacity of the X-BT threaded stud

### 5.2.1 Tensile load deformation behavior of X-BT threaded stud fastenings

#### Load-displacement behavior of blunt-tip stainless steel threaded studs,

Report No. XE\_02\_03; Reinhard Buhri; January 2002

#### Evaluation report on 5S (X-BT)-fastenings,

Report No. XE\_02\_36; Hermann Beck, July 2002

Base material	Steel, 20mm thick, $f_u = 385 \text{ MPa}$ (S235) and $f_u = 630 \text{ MPa}$ (S355)
Number of fastenings in test	11 (6 in S235, 5 in S355)

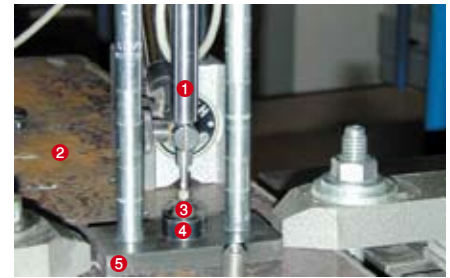
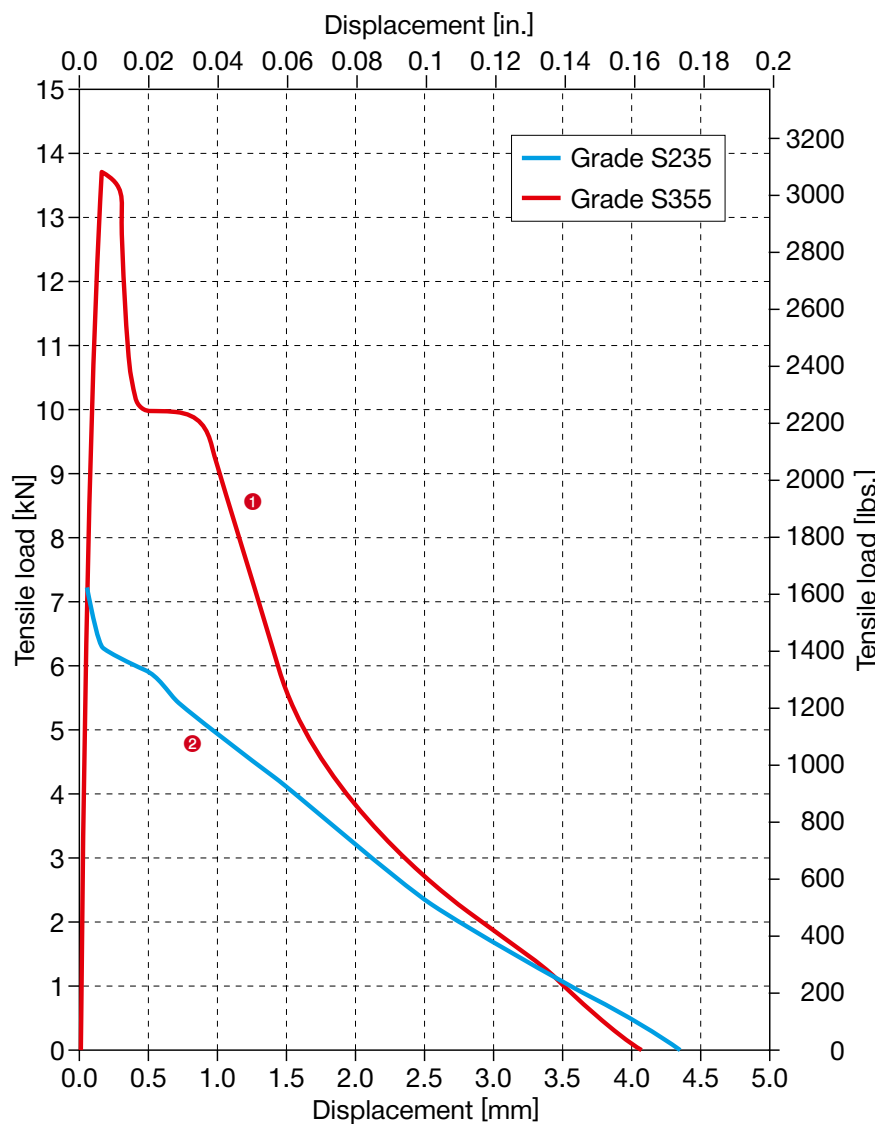

- 1 Displacement sensor
- 2 Base steel
- 3 X-BT-M10-24-6
- 4 Special nut, M10
- 5 Loading plate

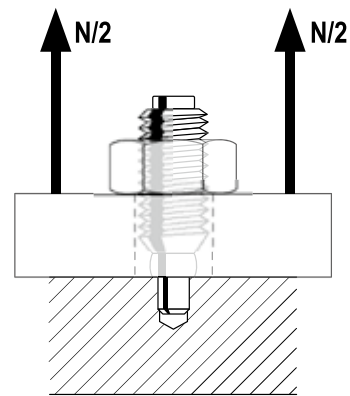

- 1 Load-displacement curve of one specimen selected as being representative for the five specimens tested.
- 2 Load-displacement curve of one specimen selected as being representative for the six specimens tested.

#### Conclusions

- Very stiff up to maximum load
- Significant resistance to pull-out even after relatively large displacement
- Ultimate pull-out loads increase with increasing base steel strength
- The continued resistance during pull-out and the dependency of ultimate pull-out load on base steel strength indicates that the fastener fuses with the base steel

This summary is intended to be representative of the test(s) carried out. It is not intended to be a full and complete test report. For complete test details, please contact Hilti.

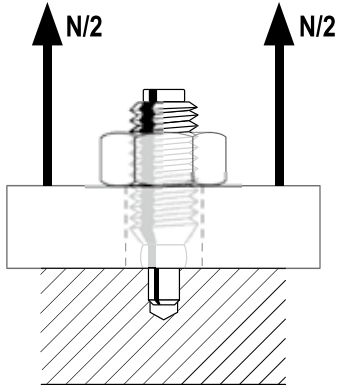

## 5.2.2 Pull-out strength of X-BT threaded stud fastenings

### Load behavior on special steel constructions,

Report No. XE\_01\_57; Reinhard Buhri; 30 November 2001

### Pull-out strength of blunt tip stainless steel threaded studs,

Report No. XE\_02\_23; Reinhard Buhri; 9 April 2002

Base material	Steel, 6, 8, 10, 12 and 15 mm thick, S235 and S355
Number of fastenings in test	200 total, (20 per situation of thickness and steel grade)

### Ultimate pull-out load as a function of base steel ultimate tensile strength

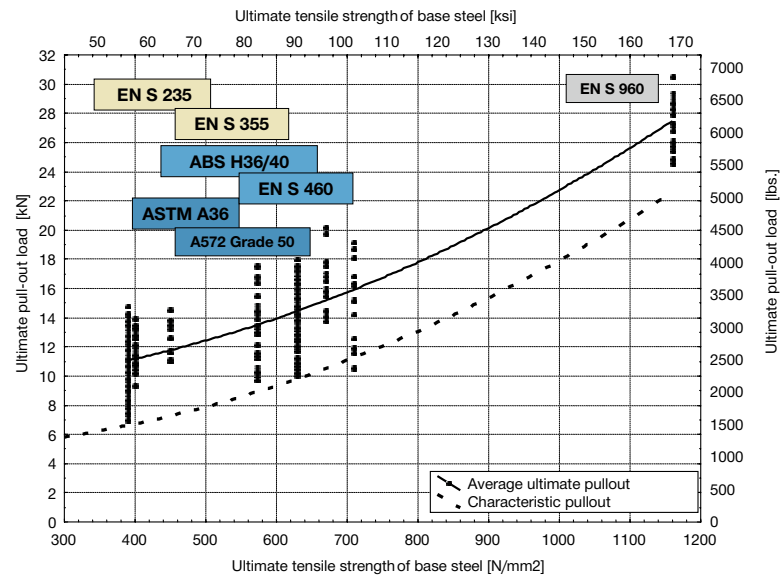

### Ultimate pull-out load as a function of base steel thickness X-BT threaded studs in S235 [A36] steel

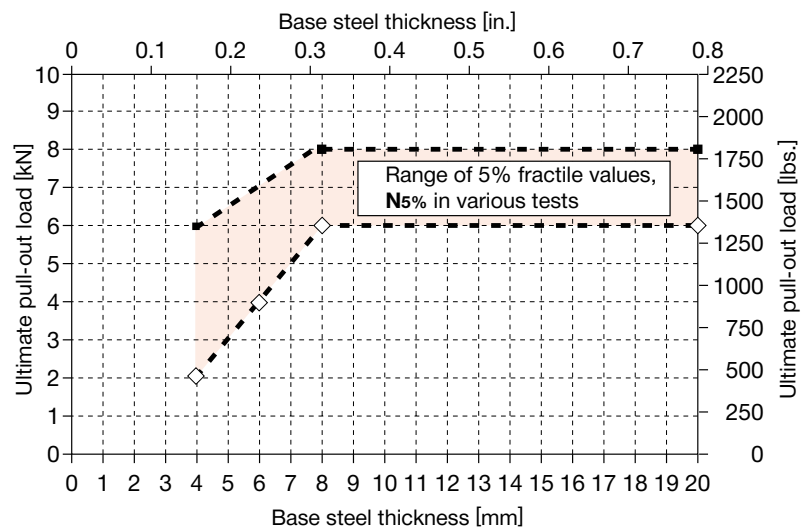

### Conclusions

- For steel thickness  $\geq 8$  mm, 5% fractile pull-out  $\geq 6$  kN without regard to steel grade
- Lower pull-out values with S235/A36
- Higher pull-out values with thermomechanical hot-rolled fine-grain steel according to ABS and EN 10025-4 and quenched and tempered high-grade steel according to EN 10025-6

This summary is intended to be representative of the test(s) carried out. It is not intended to be a full and complete test report. For complete test details, please contact Hilti.

### 5.2.3 Shear strength of X-BT threaded stud fastenings

**Evaluation report on 5S fastenings,**

Report No. XE\_02\_36; Hermann Beck; 4 July 2002

**Load behavior on static shear loading,**

Report No. XE\_01\_45; Reinhard Buhri; 10 October 2001

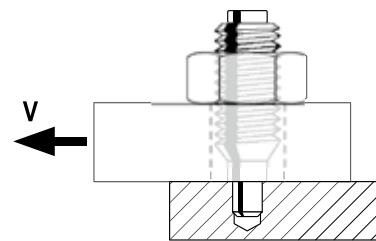

Base material	Steel, 8 to 10 mm thick, S235 and S355
Fastened material	Steel, 15 mm thick
Number of fastenings in test	12 (S235) and 8 (S355)

**Load-displacement behavior**

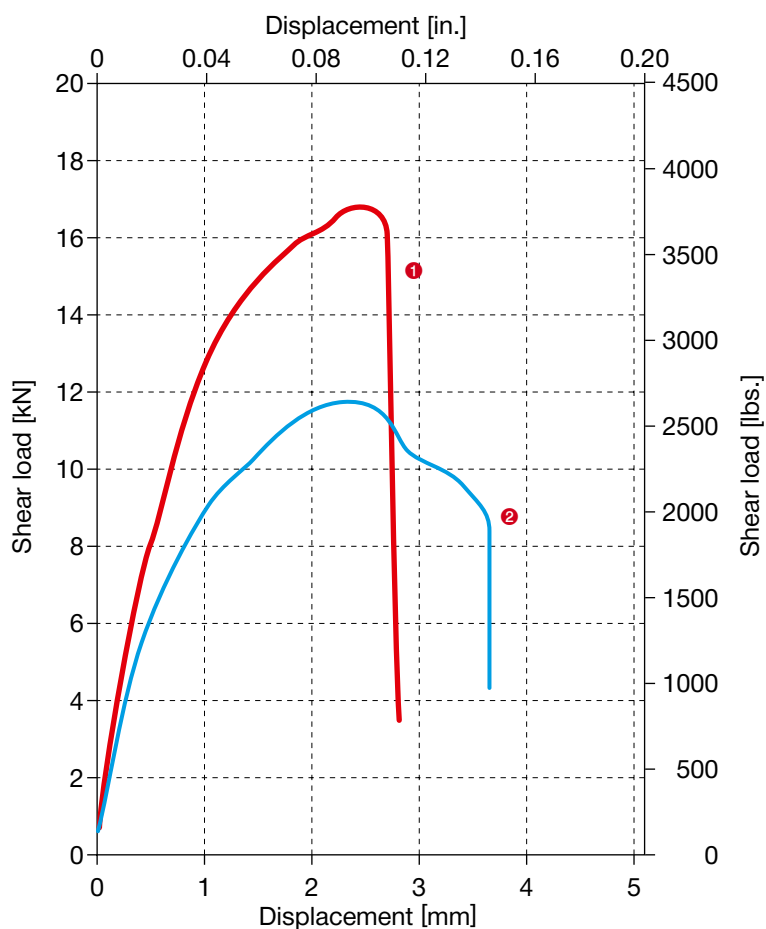

**1 S355 steel**  
Load-displacement curve of one specimen selected as being representative for the eight specimens tested.

**2 S235 steel**  
Load-displacement curve of one specimen selected as being representative for the twelve specimens tested.

	Average ultimate shear $V_{u,m}$ [kN (lbs)]	Deformation at $V_{u,m}$ [mm (in)]	Mode of failure
<b>1</b> S355 ( $f_u = 630\text{MPa}$ )	16.77 (3770.0)	2.45 (0.096)	12% base steel failure + pull-out 88% fastener fracture
<b>2</b> S235 ( $f_u = 390\text{MPa}$ )	12.02 (2702.2)	2.42 (0.095)	67% base steel failure + pull-out 33% fastener fracture

**Conclusions**

- Shear strength of the fastening increases with base material strength
- Failure mode with high-strength steel (S355, Grade 50) predominately fastener fracture
- Failure mode with lower-strength steel (S235, A36) predominately base metal failure and pull-out

This summary is intended to be representative of the test(s) carried out. It is not intended to be a full and complete test report. For complete test details, please contact Hilti.

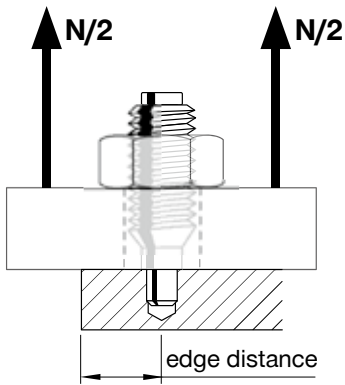

### 5.2.4 Effect of edge distance/spacing on pull-out strength of X-BT fastenings

**Tensile and shear loading in small steel beams,**

Report No. XE\_02\_39; Reinhard Buhri; 16 July 2002

**Effect of edge distance and fastener spacing on ultimate pull-out,**

Report No. XE\_02\_28; Reinhard Buhri; 23 April 2002

**Stainless steel studs without point,**

Report No. XE\_02\_23; Reinhard Buhri; 9 April 2002

#### Edge distance

Base material	Steel, 8 mm thick, S235 (fu = 390MPa)
Number of fastenings in test	120 total, (20 per edge distance)
Edge distances tested	3, 4, 5, 6, 7, 8 and 25 mm

#### Test concept

- 1) Place groups of fastenings at various edge distances
- 2) Pull out all fastenings
- 3) Compare ultimate pull-out loads for the various groups to existing ultimate pull-out data

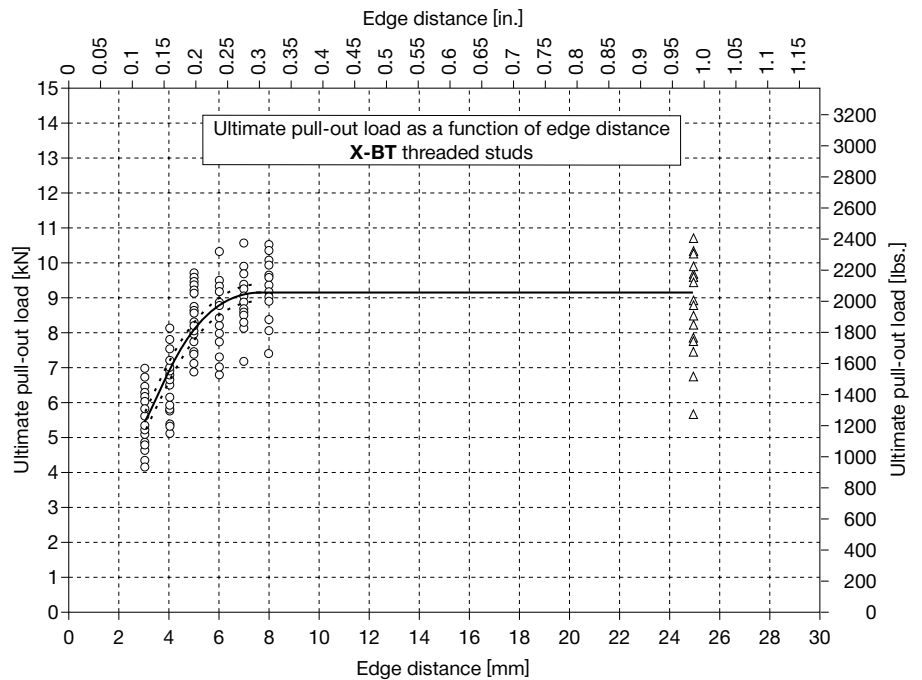
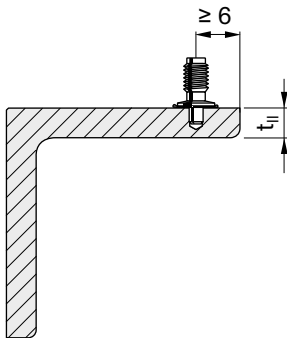

#### Conclusions

- Increasing the edge distance to more than 6 mm does not result in increased ultimate pull-out.
- An edge distance of 6mm is adequate to avoid reduction in recommended load.

This summary is intended to be representative of the test(s) carried out. It is not intended to be a full and complete test report. For complete test details, please contact Hilti.

**Tensile and shear loading in small steel beams,**

Report No. XE\_02\_39; Reinhard Buhri; 16 July 2002

**Effect of edge distance and fastener spacing on ultimate pull-out,**

Report No. XE\_02\_28; Reinhard Buhri; 23 April 2002

**Stainless steel studs without point,**

Report No. XE\_02\_23; Reinhard Buhri; 9 April 2002

**Fastening spacing**

Base material	Steel, 8 mm thick, S235 ( $f_u = 390$ MPa)
Number of fastenings in test	60 total, (20 per spacing)
Spacings tested	15, 20 and 25 mm

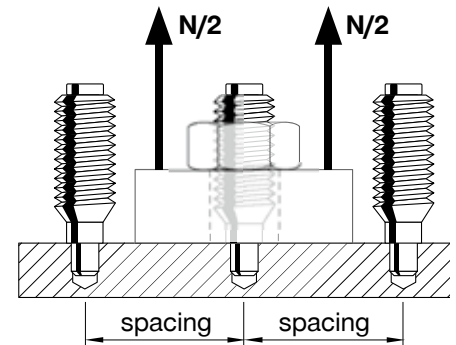

**Test concept**

- 1) Place groups of fastenings at various spacings
- 2) Pull out all fastenings
- 3) Compare pull-out loads of the various groups and to existing pull-out data

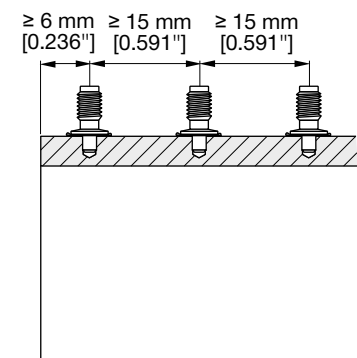
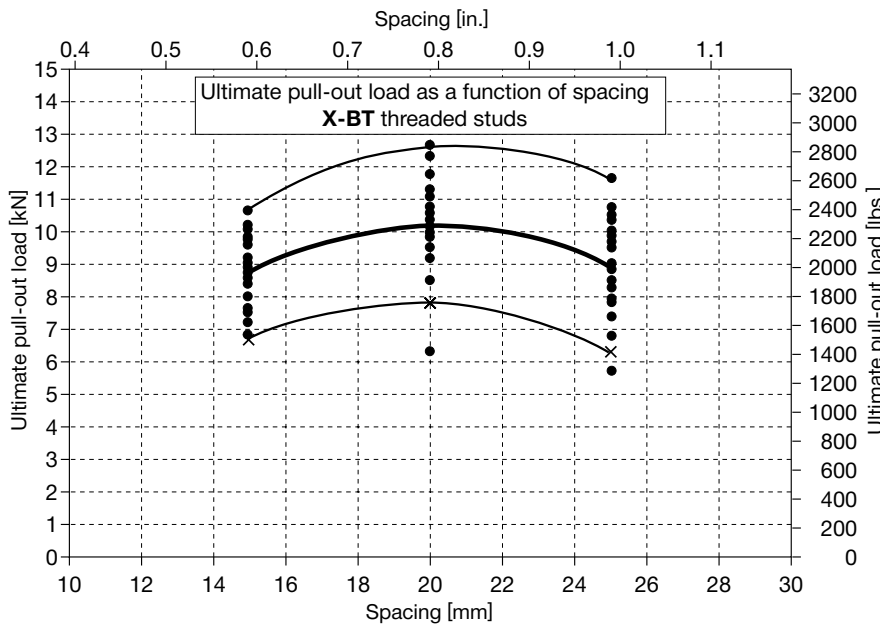

**Conclusions**

- Increasing the fastener spacing to more than the 15 mm as dictated by the base-plate on the DX 351 tool does not significantly increase ultimate pull-out.
- A fastener spacing of 15 mm is adequate to avoid reduction in recommended load.

This summary is intended to be representative of the test(s) carried out. It is not intended to be a full and complete test report. For complete test details, please contact Hilti.

## 5.2.5 Holding mechanisms of X-BT threaded studs

### Anchoring mechanisms of the Hilti X-BT fastening system,

Rheinisch-Westfälische Technische Hochschule, Aachen,

Prof.-Ing. Wolfgang Bleck, 7 November 2002

**Investigation of welding between stainless steel X-BT fastener and S235 / S355 steel base material**, Report TWU-IFM 213/01, Birgit Borufka, 2001

**Load behavior of stainless steel studs without tip**,

Report XE-01-05, Reinhard Buhri, March 2001

### Investigation concept

- 1) Consider difference between X-CR austenitic stainless steel (corresponds to X2CrNiMoNbN25-18-5-4) and construction grade ferritic steels S235/S355 per DIN EN 10025 (similar to ASTM A36/A572 Grade 50).
- 2) Examination of metallographic cross-sections at various distances from the surface of the base steel.
- 3) Examination of pulled out X-BT fasteners.

### Differences between fastener material and base steel material

- **CR500** steel is 3 times harder than ferritic construction steel.

<b>CR500</b> austenitic stainless steel:	$f_u \geq 1850\text{MPa}$
Construction grade steels	
S235 (per DIN EN 10025):	$f_y \geq 235\text{MPa}$ , $f_u = 340 - 510\text{MPa}$
S355 (per DIN EN 10025):	$f_y \geq 355\text{MPa}$ , $f_u = 470 - 630\text{MPa}$

- The hardness of **X-CR** steel is less affected by increasing temperature than ferritic construction steel. Thus it can be concluded that the hardness difference is maintained during driving as well and a new surface is formed at the interface of base steel and fastener.

### Examination of cross-section

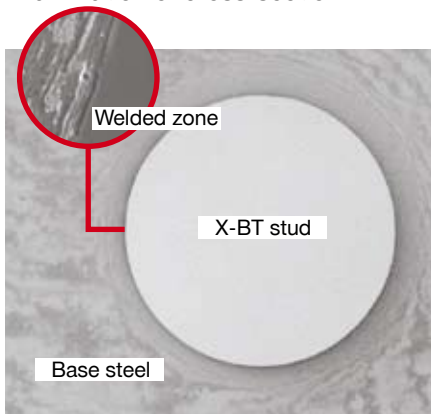

### Examination of pulled-out X-BT threaded stud

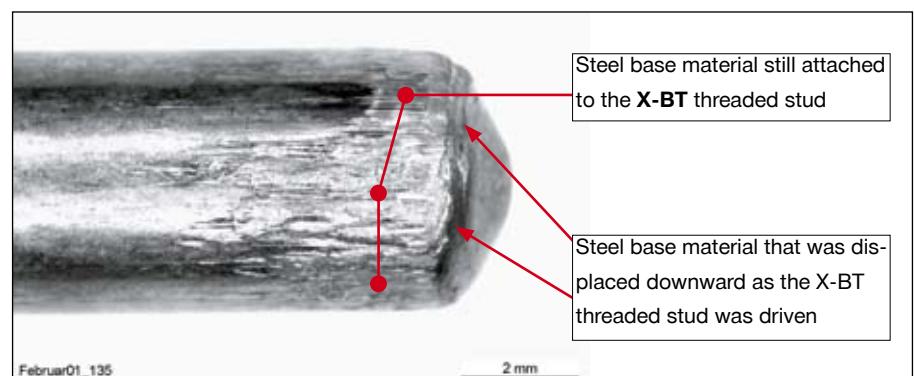

### Description of the holding mechanism

- Anchorage of the X-BT fastener in steel develops due to friction and fusion (friction welding). The characteristics of friction welding are: concentrated heat development, grain refinement due to hot and cold working, and little diffusion across the interface of the welded components.
- A definite interface exists along the entire perimeter of the fastener shank
- The drilled hole below the tip of the X-BT threaded stud is sealed
- The interface of the fastener shank in each cross-section is between 55% and 100% welded to S235/A36 steel base material.
- The interface of the fastener shank in each cross-section is between 75% and 100% welded to S355/Grade 50 steel base material.

This summary is intended to be representative of the test(s) carried out. It is not intended to be a full and complete test report. For complete test details, please contact Hilti.



### 5.3 Corrosion resistance

#### 5.3.1 X-BT threaded stud fastening corrosion data

Blunt-tip stainless steel stud with sealing washer,

Report No. XE\_02\_13; Reinhard Buhri; June 2002

#### Corrosion data

Base material	Steel, 8 mm thick, S235 ( $f_u = 385$ MPa) and S355 ( $f_u = 630$ MPa)
Number of fastenings in test	120 total, (60 per steel grade)
Salt spray test	90 days, performed according to DIN 50 021SS / ASTM G 8585)

#### Test concept

- 1) Make 60 fastenings in steel of each grade (S235 and S355 steel).
- 2) Pull out 30 fastenings from each steel grade before performing the salt spray test.
- 3) Pull out 30 fastenings from each steel grade after the salt spray test.
- 4) Compare the ultimate pull-out loads before and after the 90 day salt spray test for each steel grade.
- 5) Examine the area around the fastening points after pulling out the fasteners

#### Pull-out test results for S355 steel

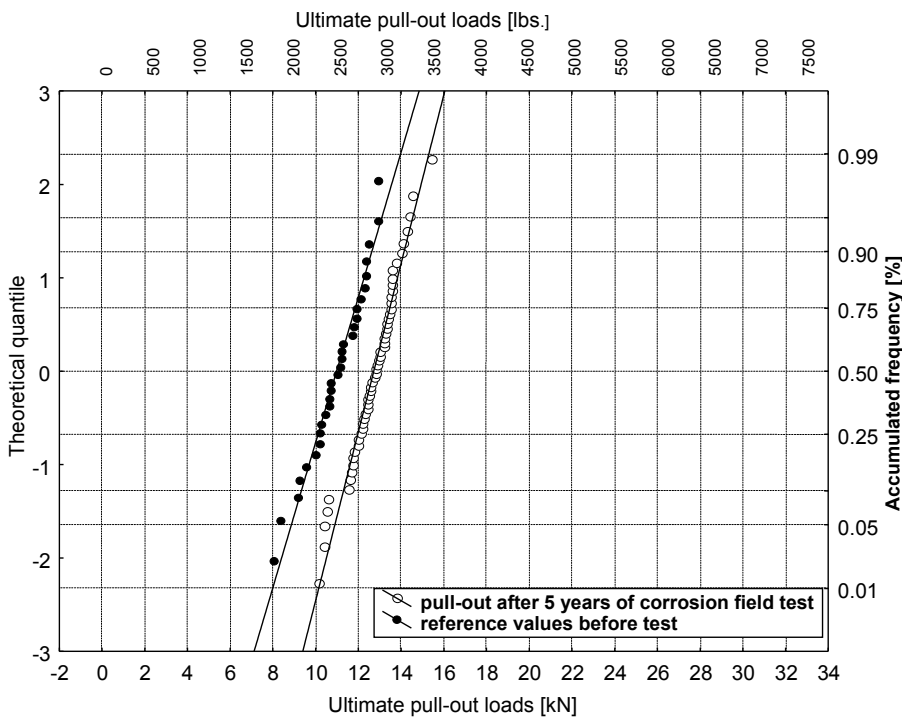

#### Summary of results from the pull-out tests

- For the S355 steel, the ultimate pull-out after the salt spray test were slightly lower than those for before the salt spray test. This is attributed to data scatter and not to any physical phenomena.
- Similar results for S235 steel grade.

This summary is intended to be representative of the test(s) carried out. It is not intended to be a full and complete test report. For complete test details, please contact Hilti.

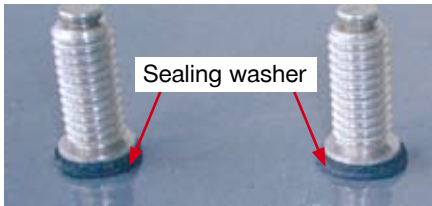

Prepared X-BT fastenings after driving



Drilled holes after 90 days salt spray test and after pull-out of the X-BT fasteners. These holes appear clean and no evidence of corrosion is visible.

## Observations and examination

After 90 days of salt spray, the bottom side of the 8 mm [0.315"] steel plate was examined. No evidence of damage or corrosion could be found.

### Corrosion resistance of Hilti CR500 stainless steel in comparison with AISI 304 and AISI 316;

FMPA Baden-Württemberg; Report No. VI.10.1.7c; July 2000

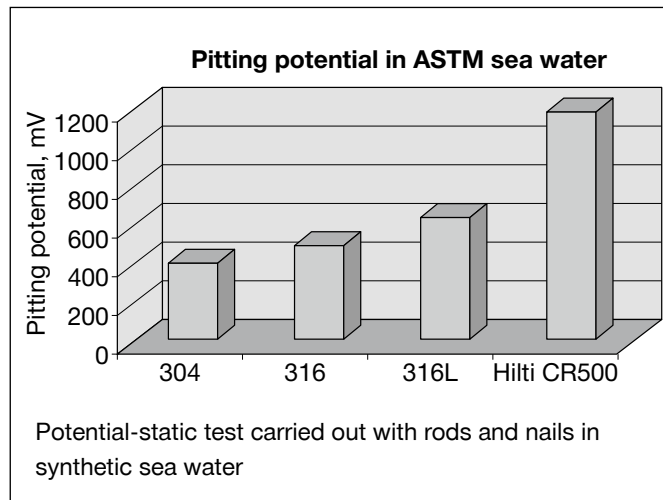
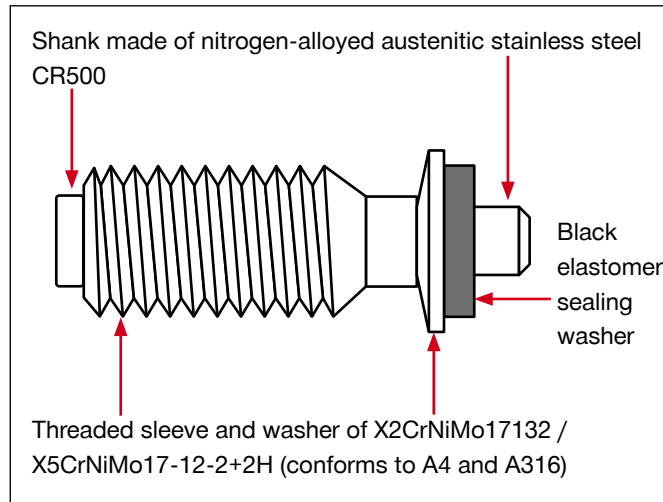

### Conclusions from the tests

- Ultimate pull-out of the fastenings was not affected by 90 days of salt spray test.
- After 90 days salt spray test no corrosion was found in the drilled holes. This is strong evidence that the sealing washer provides an effective seal.
- After 90 days salt spray test, there was no evidence of corrosion on the bottom side of the steel plate. This shows that drilling the hole and driving the fastener does not cause damage on the bottom side.
- CR 500 is at least as resistant as AISI grade 316.

### 5.3.2 Contact corrosion – X-BT stainless steel stud in carbon steel

**Corrosion behavior of X-CR fasteners,**

Report No. VI.10.1.7; FMPA Stuttgart; May 1994.

**Corrosion behavior of stainless steel DX fasteners in carbon steel;**

G. Felder and M. Siemers, Schaan, September 2005

**General comments**

Two materials of different resistance/polarity exposed to the same media, in direct electrical contact, lead to accelerated corrosion of an electrochemically “less noble” material in contact with a “noble” material. The material loss of the noble partner is reduced, the loss of surface area of the less noble partner is increased. Prerequisite for this form of corrosion is an electrically conductive connection between these two materials.

Whether contact corrosion occurs depends also on the **surface area ratio**.

If the surface of the less “noble” material (1) is greater than that of the more “noble” material (2), it will act as a very small cathode and the current density on the “large anodic” less noble material will be very small. Further, this also implies a very low rate of corrosion of the “less noble” material due to electrochemical effects.

However, if the surface of the less “noble” material (1) is smaller than that of the more “noble” material (2), the rate of corrosion of the “less noble” material will be very high.

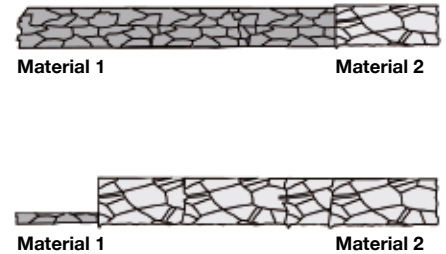

**Hilti X-BT in carbon steel**

Where stainless steels are concerned, contact corrosion is not a matter of concern. Stainless steels are higher in the galvanic series, i.e. more noble than most generally used materials such as aluminium, zinc and steel. Stainless steel in contact with these materials thus gains cathodic protection. Contact therefore generally has a favorable effect on the corrosion properties of stainless steels.

Due to the electrochemical effects as described above, the “noble” stainless steel fastener induces a very low rate of corrosion of the “less noble” base material and fastened material, or possibly no corrosion at all. This behavior has also been confirmed in a number of salt spray tests and in long-term tests with exposure to sea water in the tidal zone on an island in the North Sea.

In all of these tests, no corrosion occurred. The condition of a specimen after seven years of sea water tests is shown in the photo on the left. No evidence of corrosion can be found at the anchoring zone of the X-BT fastener. The seal achieved has remained fully functional, no electrolyte is present and contact corrosion is not an issue.



Steel base material after 7 years of exposure to sea water and pull-out of the X-BT fastener. The hole appears clean and no evidence of corrosion is visible.

This summary is intended to be representative of the test(s) carried out. It is not intended to be a full and complete test report. For complete test details, please contact Hilti.



- 8 specimens in an atmospheric testing rig in accordance with ISO 8565
- 16 specimens in a sea water testing rig, wave zone and tide zone, in accordance with ISO 11306



Marine atmosphere test rig with X-BT test specimens installed.



See water test rig with test specimens installed (X-BT with and without X-FCM grating discs).



### 5.3.3 Corrosion data from field tests at Helgoland Island (North Sea)

**Expert assessment of the corrosion resistance of Hilti X-BT fasteners in marine atmospheres and in sea water,**

9004742000 ZG/Bf; MPA, University of Stuttgart; July 2009

#### Test material

Base material	S235 steel ( $f_u = 439$ MPa), 8 mm thick
Number of specimens	24 steel plates, each with 18 X-BT studs

#### Test procedure

The test specimens were installed in May 2003 and samples taken periodically from each zone for assessment in June 2004, June 2005, May 2008 and June 2010.

Microscopic and metallurgical investigations to assess corrosion were carried out by MPA, University of Stuttgart. The tensile resistance tests were carried out by Hilti under supervision of the MPA.

#### Test results

Test specimens after 7 years of exposure to sea water in the tidal zone of the North Sea. No evidence of corrosion is visible on the X-BT studs and X-FCM discs. Only slight discoloration due to deposits can be observed on the X-FCM discs.

#### Conclusions

- After 7 years of exposure to sea water, no corrosion was found on the X-BT fasteners.
- After 7 years of exposure to sea water, no corrosion was found on the X-FCM fasteners.
- After 7 years of exposure to sea water, no corrosion was found in the drilled holes. This is strong evidence that the sealing washer provides an effective seal.
- Ultimate pull-out strength of the fasteners was not affected by the field tests. The pull-out load achieved in monitoring tests carried out in June 2003 was 8.6 kN, and in 2008 it was 10.5 kN.

Based on the long-term tests carried out by the MPA as described above, the University of Stuttgart [Expert Assessment, 9004742000 ZG/Bf] came to the following conclusion:

**From a corrosion point of view it can be assumed that the Hilti X-BT system will have a lifetime of over 20 years, even under conditions of use where chlorides are present.**

Steel base material after 7 years of exposure to sea water and pull-out of the X-BT fastener. The hole appears clean and no evidence of corrosion is visible.

## 5.4 Effect of X-BT threaded stud fastenings on steel base material

### Experimental investigations on the effect of X-BT fasteners on the static strength of the base material structural steel

Report No. XE\_02\_07; Hermann Beck; 17 June 2002

### Experimental investigations on the effect of X-BT fasteners on the fatigue strength of the base material structural steel

Report No. 2010-57X by Prof. U. Kuhlmann and H.P. Günther from the University of Stuttgart: Fatigue classification of the constructional detail "Structural steel base material with the Hilti powder-actuated fastener X-BT" in compliance with Eurocode 3 Part 1-9 (EN 1993-1-9), (2010)

Reports No. 453'150/1e, 453'150/2e, 453'150/3e, 455'377/e by EMPA, Swiss Federal Laboratories for Materials Testing and Research (2010)

Report No. TWU-FSRL-13/09 by Hilti FSRL, Fastening System Research Laboratories (2010).



Base material (static tests):	Steel, 8 and 10 mm, S235 and S355
Base material (fatigue tests):	Steel, 8, 20 and 40 mm, S235, S355, S460M, S460G4+M
Number of fastenings in test:	48 static tensile and 191 fatigue tests

### Load-deformation behavior of steel with X-BT fasteners

Evaluated in tensile tests performed with coupons with X-BT fasteners (XE\_02\_07)

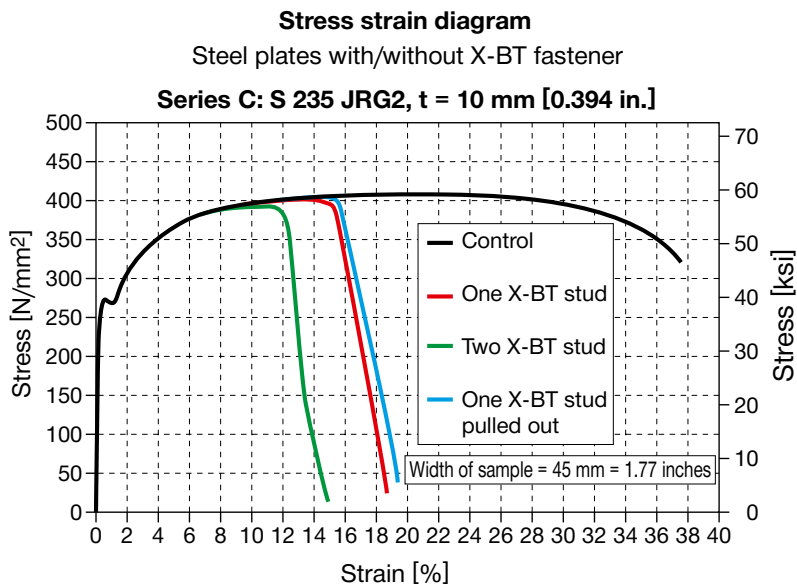

### Conclusions

- The very high net section efficiencies observed with Hilti DX powder-actuated fasteners also develop for plates with X-BT fasteners.
- Generally, the presence of an X-BT fastener need not be taken into account in the design of tensile members made of structural steel.
- In case of exceptionally high fastener concentrations (net area < 92 % of gross area), application of the design provisions of AISC-LRFD or Eurocode 3 for drilled holes leads to conservative results.

This summary is intended to be representative of the test(s) carried out. It is not intended to be a full and complete test report. For complete test details, please contact Hilti.

## Fatigue classification of the constructional detail “Structural steel base material with the Hilti powder-actuated fastener X-BT” in compliance with Eurocode 3 Part 1-9 (EN 1993-1-9)

A comprehensive test program of constant amplitude fatigue tests of plates with X-BT fasteners was performed from 2009 to 2010 at EMPA (Swiss Federal Laboratories for Materials Testing and Research) and at Hilti FSRL (Fastening System Research Laboratories).

The graph shows an example of test results with the following parameters:  
Steel:  
Off-shore grade S460G4+M according to EN 10225 with a thickness of 40 mm  
Stress ratio  $R = 0.5$

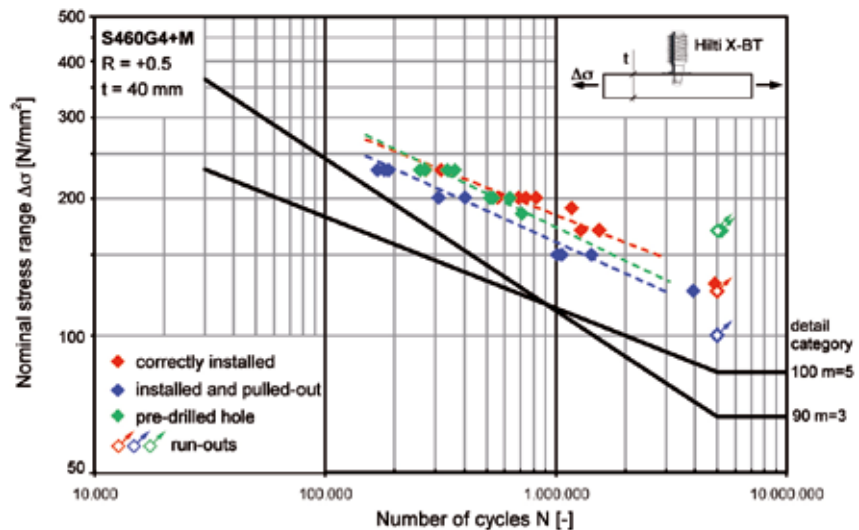

The result of the fatigue classification is summarized in the following table, taken from the expert statement by Prof. U. Kuhlmann and H.P. Günther from the University of Stuttgart (Report No. 2010-57X).

Detail category	Construction detail	Description	Requirements
<p>90 <math>m = 3</math></p> <p>100* <math>m = 5</math></p>		<p>Hilti X-BT powder-actuated fastener with pre-drilled hole in structural steel base material.</p> <p>Imperfect fastener installations as e.g. pulled-out fasteners or pre-drilled holes without fasteners are covered.</p>	<p><math>\Delta\sigma</math> to be calculated by the gross cross-section.</p> <p>Installation, static loading and spacing of fasteners only in accordance with the requirements given in [1] or [2].</p> <p>Plate thickness <math>t \geq 8</math> mm.</p> <p>When using a fatigue assessment procedure based on a linear damage calculation a mixture of both detail categories given is not allowed.</p>
<p>* Detail category 100 with a slope of <math>m = 5</math> is recommended for very high number of load cycles, as this detail category better fits to the constant amplitude fatigue limit a 5 million cycles.</p> <p>[1] Hilti X-BT threaded fastener. Specification Binder, Edition 07/2003 and Edition 12/2010</p> <p>[2] Hilti Direct Fastening Technology Manual. Edition 11/2009. pp. 2.119-2.124</p>			

### Conclusion

- The classification covers structural steel grades S235 up to S460 according to EN 10025-2, EN 10025-3, EN 10025-4 and EN 10225 including normalized and thermomechanical rolled fine grain steels.
- The detail category for the X-BT exceeds the detail category for welded studs (80,  $m=3$ ).
- In comparison with constructional details usually occur in welded structures, the effect of X-BT is normally less detrimental compared with the welded details.
- The tests results are in well agreement with the effect of Hilti DX powder-actuated fasteners driven into steel without pre-drilling.

The implementation of the fatigue classification into the approvals (see 3.1.3) of the X-BT is currently ongoing.

This summary is intended to be representative of the test(s) carried out. It is not intended to be a full and complete test report. For complete test details, please contact Hilti.

## 5.5 Vibration effects on X-BT threaded stud fastenings

### Experimental investigations on the effect of base metal vibrations on the ultimate pull-out

Report No. XE\_02\_09; Hermann Beck; 19 June 2002

Base material	Steel, S235
Beam section	HE-A section, 9 mm flange, 6 mm web
Test procedure:	Beam loaded in the center $F_{max} = 155 \text{ kN}$ , $F_{min} = 33 \text{ kN}$ Frequency = 6 Hz Number of cycles = 2 Million
Number of fastenings:	210 X-BT fasteners, some with X-FCM-R grating disks



1 Compression flange  
 2 Tension flange



3 Markings to measure disc rotation

### Ultimate pull-out of X-BT fasteners before and after cyclic loading of the steel beam

#### X-BT fasteners in area without grating

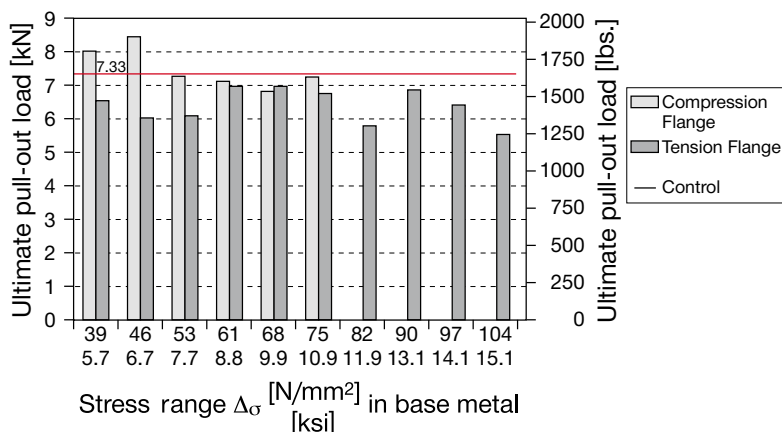

7.33 = Ultimate pull-out on the sample before stress was applied (control). No measurements taken on the compression flange in the high stress area due to position of the press.

#### X-BT fasteners in area with grating

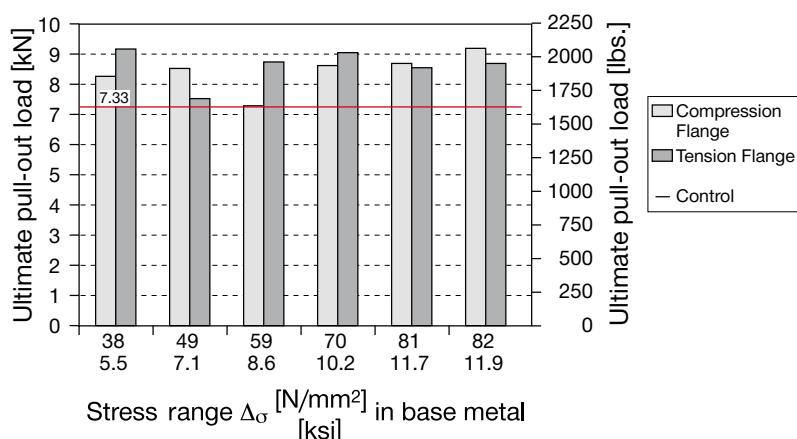

7.33 = Ultimate pull-out on the sample before stress was applied (control).

### Conclusions

- Cyclic loading applied to steel beams, which causes vibration on the fastener, has only a negligible effect on the ultimate pull-out of X-BT threaded studs
- Cyclic loading applied to steel beams, which causes vibration on the fastener, does not result in loosening of grating X-FCM-R grating disks

This summary is intended to be representative of the test(s) carried out. It is not intended to be a full and complete test report. For complete test details, please contact Hilti.

## 5.6 Temperature resistance of X-BT threaded stud fastenings

Direct Fastening Technology Manual, Edition 11/2009

Report No. XE\_07\_78; R. Buhri, December 2007

The temperature resistance of the Hilti X-BT fastening system is controlled by

- the temperature resistance of the stud
- the resistance of the X-BT stud anchorage in steel base material
- the effect of temperature on the corrosion resistance of the stud
- the temperature resistance of the SN12-R sealing washer

### Temperature resistance of the X-BT stud material

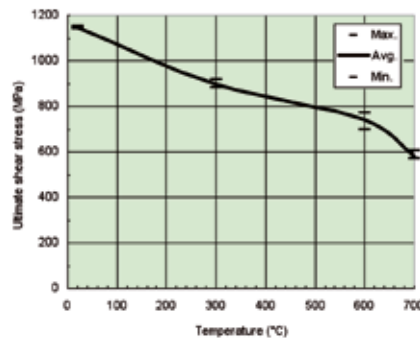

Tests at Swiss Federal Laboratory for Material Testing (EMPA)

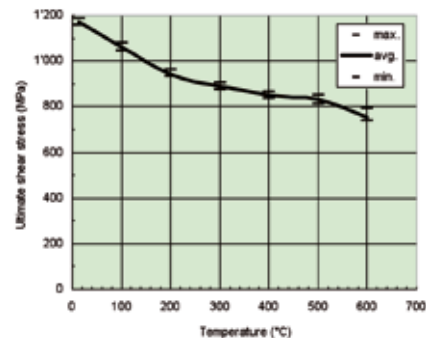

Tests at JTICM Laboratory Japan

At 600°C, the X-BT material has about 64% of its 20°C strength left. By comparison, structural steel has only about 26%.

With a minimum tensile strength of  $f_u = 1850 \text{ N/mm}^2$  the ultimate tensile resistance of the X-BT stud at 600°C is about 18.8 kN.

### Temperature resistance of the X-BT stud anchorage in steel

Steel base material:	Grade	Thickness [mm]	Strength Rm [MPa]
	S 235	8	455
	EH 36	8	536

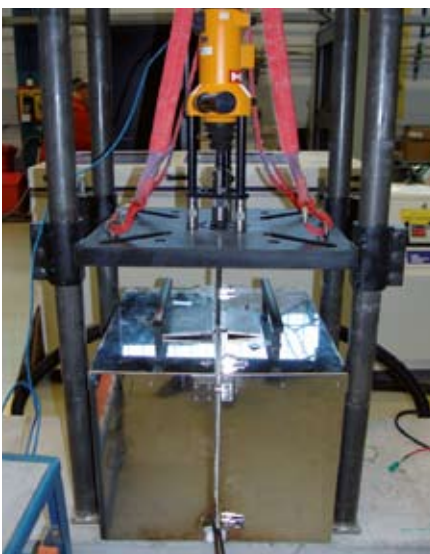

Tension cylinder on the furnace

### Pull-out test configuration



X-BT on 8.0 mm base plate



Open furnace chamber

This summary is intended to be representative of the test(s) carried out. It is not intended to be a full and complete test report. For complete test details, please contact Hilti.



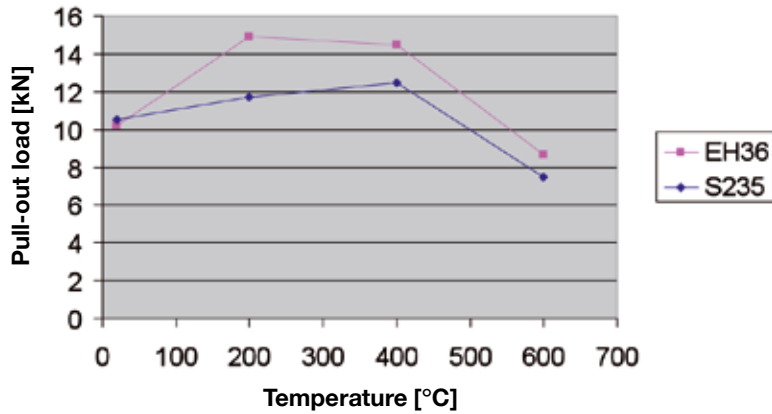

At 600°C, the pull-out resistance of the X-BT has about 71 % of its 20°C strength left in steel S235 and about 85% in steel EH36.

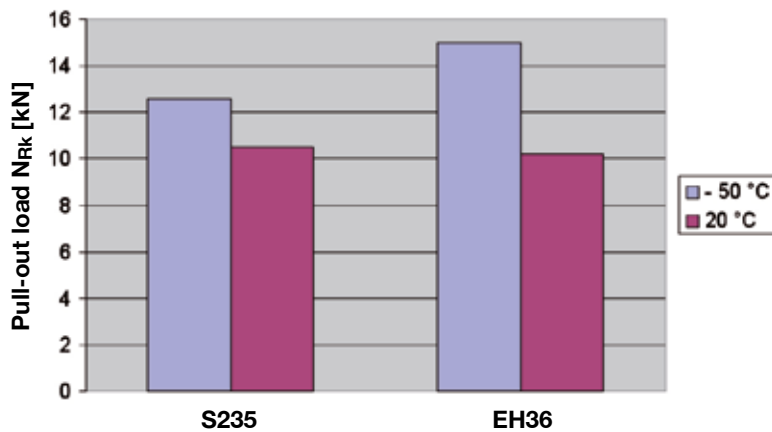

At low temperature the pull-out resistance is increasing compared to that at room temperature.

**Conclusions**

- The strength of the X-BT stud and its anchorage in steel base material does not control the limits of the system under extreme ambient temperatures.
- The corrosion resistance of the **X-BT** stud is verified up to **+300°C**
- The sealing function of the **SN12-R** sealing washer is verified up to **+100°C**

This summary is intended to be representative of the test(s) carried out. It is not intended to be a full and complete test report. For complete test details, please contact Hilti.



Single-point test assembly

## 5.7 X-BT threaded stud for grounding and bonding equipment and lightning protection systems

Test Report No. 09-IK-0208.32V2\_e; Electrosuisse, Fehraltorf, Switzerland;  
May 2010

Test Report No. CF-791; Dehn und Söhne GmbH, Neumarkt, Germany;  
March 2006

Test Report No. 70064671; TÜV Test Centre, Frankfurt, Germany;  
March 2004

### 5.7.1 Protective grounding and bonding

According to IEC 60947-7-2, a terminal shall be capable of withstanding a current for a short time (exposure time of 1 second).

$$I_{\text{test}} = A_{\text{cable}} [\text{mm}^2] \times 120 [\text{A}/\text{mm}^2]$$

$A_{\text{cable}}$  – cross sectional area of the attached cable, exposure time 1 second

Studs	X-BT M10-24-6 SN12-R X-BT M6-24-6 SN12-R
Stud material	Hilti CR500, EN 10088-3 (1.4462) and Hilti HCR (1.4529)
Base material	Painted steel plates, 8 mm thick

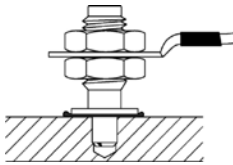
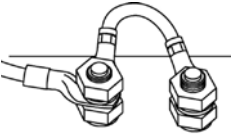
Connection point configuration	Current	Time	Result	Corresponding cable (according to EN 60439-1 and EN 60204-1)
 Single point	1215 A	1 sec.	passed	10 mm <sup>2</sup> copper
	1400 A	1 sec.	passed	10 mm <sup>2</sup> copper
 Double point	1920 A	1 sec.	passed	16 mm <sup>2</sup> copper
	2240 A	1 sec.	passed	16 mm <sup>2</sup> copper

This summary is intended to be representative of the test(s) carried out. It is not intended to be a full and complete test report. For complete test details, please contact Hilti.

## 5.7.2 External lightning protection

Lightning tests have been carried out in accordance with European Standard EN 50164-1, Lightning Protection Components (LPC), Part 1: Requirements for connection components.



Test assembly X-BT with double nut

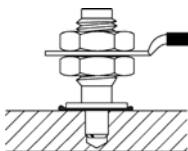
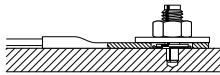

Test assembly X-BT with cable lug

Connection point configuration		Test class	$I_{max}$	Time
	<b>X-BT M10-24-6 SN12-R</b> cable clamped between 2 nuts	N	50 kA	$t_d \leq 2$ ms
	<b>X-BT M10-24-6 SN12-R</b> <b>X-BT W10-24-6 SN12-R</b> with cable directly on base material	H	100 kA	$t_d \leq 2$ ms

### Conclusions

- Maximum cable size connected with X-BT and double nuts used as a connection point for an earthing and bonding device is:
  - Single point: 10 mm<sup>2</sup> copper
  - Double point: 16 mm<sup>2</sup> copper
- X-BT and double nut used as a connection point for external lightning protection systems is classified as:
  - Test class N
  - Maximum current of 50 kA
- X-BT used as a fastener for cable lugs as a connection point for external lightning protection systems is classified as:
  - Test class H
  - Maximum current of 100 kA
- All tests have shown that the electrical current capacity of the X-BT stud is controlled by the shank of the stud and is independent of the thread diameter. Accordingly, the electrical capacities of X-BT M6, X-BT W6, X-BT M8, X-BT M10 and X-BT W10 are the same.

This summary is intended to be representative of the test(s) carried out. It is not intended to be a full and complete test report. For complete test details, please contact Hilti.

## 5.8 X-BT in stainless steel base material

Hilti internal report XE\_07\_26; Reinhard Buhri, 21.05.2007

Stainless steel is very hard, so the drilling technique differs from that used for structural steel, the material for which the X-BT system has been optimized. Driving the X-BT stud in stainless steel presents no problem, but drilling is decisive.

### Test material and conditions

Type of drill bit:	Standard TX-BT 4/7 step shank drill bit Two special shank drill bits for stainless steel
Type of stainless steel material:	Material number: 1.4401, 1.4462, 1.4529, 1.4539
Drilling procedure:	Wet or dry
Number of tests:	495 drilling operations with 28 drill bits
Condition:	Hand held operation, same as the standard operation

### Results

- With all of the stainless steel materials tested, the standard TX-BT 4/7 drill bit was found to perform better than special drill bits.
- Cooling the drill bit does not lead to better results.
- Use of a mains-powered electric drill is recommended due to the longer drilling time.
- Best results are achieved with a mains-powered drill set to a speed of 1,000 r.p.m.
- To achieve satisfactory drilling performance, much higher pressure must be applied to the drill bit.
- About 25 to 35 holes can be drilled with a TX-BT 4/7 drill bit.
- Characteristic pull-out loads are in the 8 to 16 kN range, which provides an adequate safety factor the recommended loads.

### Recommendation

For making fastenings in stainless steel with Hilti X-BT studs we recommend use of the standard TX-BT 4/7 drill bit with a mains-powered electric drill (not a cordless tool) set to a speed of 1,000 r.p.m. The following models are suitable:

- Hilti SR 16
- Hilti UH 650

## 5.9 X-BT under shock loading

Shock tests with X-BT studs and MQ channel systems for fastening electrical cable and pipe runs are described in these documents:

Test certificate number QUINETIQ/CMS/TC040089;

QinetiQ Shock Test Laboratory, 15.01.2004

Report 2004-CMC-R017, TNO Delft, Netherlands, 29.05.2005

Mechanical and electrical equipment fastened with MQ channels and X-BT studs tested under shock load.

- Small-bore pipe runs
- High-voltage cable runs
- T-bars for fastening high-voltage cables
- Cable basket electrical runs
- Cable tray electrical runs

All applications were tested with an effective acceleration of  $1844 \text{ m/s}^2$  in the three orthogonal axes, in horizontal (longitudinal and side to side) and vertical direction. In another test, X-BT studs with a mass of 3 kg each were installed on a shock test rig and tested with a maximum effective acceleration of  $4905 \text{ m/s}^2$ .

### Test results

- The channel system, the X-BT studs and the attached equipment remained captive at all times.
- The tested effective acceleration of  $1844 \text{ m/s}^2$  corresponds to a shock load of 188 g.
- The X-BT with a fastened mass of 3 kg withstood a shock load of 200 G in horizontal (shear) and 500 G in longitudinal (tension) direction.

**Note:** For more detailed information please contact Hilti.



Test configuration: Two base plates were populated with MQ channel fastened with X-BT studs. The base plates were rigidly attached to the 2-tonne shock loading machine.

## 5.10 X-BT stud in steel with a thickness of less than 8 mm

### 5.10.1 Pull-out capacity in thin steel

#### Load behavior on special steel structures,

Report XE\_01\_57; R. Buhri; 30. 11. 2001

#### Pull-out strength of blunt-tip stainless steel threaded studs,

Report XE\_02\_23; R. Buhri; 9.4.2002

The characteristic pull-out resistance of X-BT threaded studs is a bi-linear function of base steel thickness as shown in section 6.2.2. A linear function can be derived from this graph for calculation of the reduction factor for the resistance of X-BT fastenings on steel with a thickness of less than 8 mm.

Reduction factor:  $\alpha = \frac{t_{II} - 2}{6}$  ; with  $t_{II}$  : = thickness of base steel  
 $4 \text{ mm} \leq t_{II} \leq 8 \text{ mm}$

Section 6.2.2 also shows a graph for the pull-out load as a function of base steel ultimate tensile strength. The reduced loads for different steel grades can be calculated on this basis:

---

<b>A) reduced characteristic load:</b>	$N_{Rk,red} = 6.0 \text{ kN} \cdot \alpha$	for steel S235 (A36)
	$N_{Rk,red} = 7.6 \text{ kN} \cdot \alpha$	for steel S355 (A572 grade 50)

---

<b>B) reduced recommended load:</b>	$N_{rec,red} = N_{rec} \cdot \alpha$	for steel S235 (A36)
-------------------------------------	--------------------------------------	----------------------

---

#### Example

For a base steel thickness of 6 mm, the recommended loads using Hilti global safety factors are:

Steel S235 / ASTM A36:	$N_{rec,6} = 1.8 \cdot (6-2)/6 = 1.2 \text{ kN}$
Steel S355 / grade 50:	$N_{rec,6} = 2.3 \cdot (6-2)/6 = 1.5 \text{ kN}$

### 5.10.2 Shear load capacity in thin steel

- Tensile and shear strength in thin steel,  
Report XE-02-39, R. Buhri; 16.7.2002
- Bearing capacity in steel with a thickness of 4 to 6 mm,  
Report XE-02-68; R. Buhri; 31.10.2002
- Shear strength of blunt-tip stainless steel threaded studs,  
Report XE-01-45; R. Buhri; 10.10.2001
- ABS witnessed tests # MF 349780

A comparison of shear test data for 6 mm, 8 mm, 10 mm and 20 mm steel thicknesses has shown that base material thickness has no influence on the bearing capacity of the X-BT stud. The failure mode and test results shown below lead to the conclusion that this also applies to thin steel material with  $t_{II} = 4.5 \text{ mm}$ , which is the mean embedment depth of the X-BT.

X-BT shear loads on steel S235

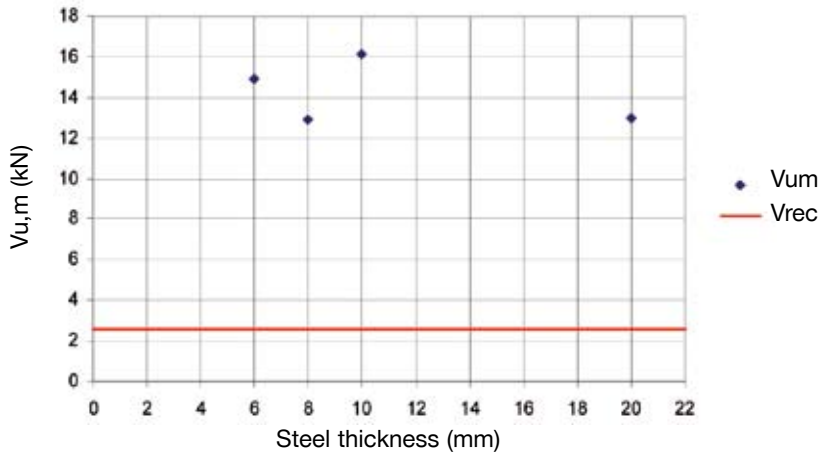

Under pure shear loads, the failure mode of X-BT studs is yielding of the steel base material as well as yielding of the stud itself, as shown in the following illustrations:



Plastic deformation of base steel



Plastic deformation of X-BT

### 5.10.3 X-BT electrical conductivity in thin steel

Reduction of the base material thickness to 6 mm will result in the same contact area between the shank of the stud and the base material as with 8 mm material (see drawing). The embedment depth of the stud is within the 4.5 to 5.6 mm range.

Due to this, a reduction in electrical conductivity in 6 mm base steel is not expected because the main parameter for electrical conductivity is the contact area between base steel and the X-BT stud.

It must be noted that no electrical conductivity tests have been carried out for base steel with a thickness of less than 8 mm. The above statement is based on an engineering judgment only.

#### General note

With a base steel thickness of less than 8 mm, it can no longer be ensured that corrosion protection on the reverse side of the steel plate remains intact.

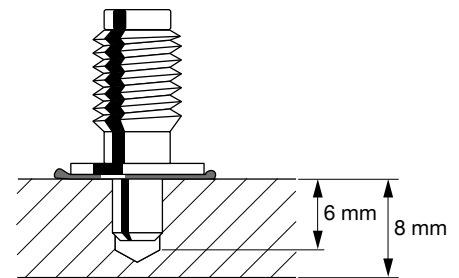

## 5.11 Chemical resistance of SN 12 sealing washer (X-BT sealing washer)

Chemicals	Volum swell					
	<20%	20-40%	>40-60%	60-80%	>80-100%	>100%
1. Water at 80°C	■					
2. Sea water	■					
3. Zinc chloride 10%	■					
4. Sodium chloride 15%	■					
5. Hydrochloric acid 10%	■					
6. Acetic acid	■					
7. Acrylonitrile				■		
8. Aniline				■		
9. n-Butyl acetate					■	
10. Diethylether		■				
11. Ethanol	■					
12. Glycerol	■					
13. n-Hexane	■					
14. Methanol	■					
15. Methylethylketone				■		
16. Nitrobenzene				■		
17. 1-Propanol	■					
18. Oil (ASTM-1) at 80°C	■					
19. Oil (ASTM-2) at 80°C		■				
20. Oil (ASTM-3) at 80°C		■				
21. Reference fuel B (isooctane/toluene, 70/30)				■		
22. Reference fuel C (isooctane/toluene, 50/50)					■	
23. Hydraulic brake fluid	■					
24. Hydraulic brake fluid at 100°C		■				
25. Antifreeze (ethylene glycol/water 50/50) at 125°C		■				

Volume swelling is a reaction of the material of the washer when it's in contact with the different substances. It's used as a parameter to describe the chemical reaction.

The swelling factor gives an indication of the behavior of the material, but swelling does not lead directly to loss of the sealing property. With an installed stud, the washer is compressed against the base steel.

Without any specific requirement it can be stated that the washer is resistant to all substances where the volume swelling value is not above 20 to 40%.



## 5.12 Material safety data sheet for SN12 sealing washer acc. to ISO/DIS 11014

### 5.12.1 Identification of substance

#### Product details

**Trade name:** Plate 2.0x650x50.000 mm OE 3.1107

**Application of the substance / the preparation:** Rubber compound

**Manufacturer/supplier:**

PHOENIX CBS GmbH, Hannoversche Straße 88, D-21079 Hamburg

**Information department:**

Conseo GmbH Abteilung Umweltschutz, Hannoversche Straße 88

D-21079 Hamburg, 040 32809 2794

**Emergency information:**





0049(0)40 7667 2233

### 5.12.2 Composition/data on components

#### Chemical characterization

**Description:** Mixture of the substances listed below with non-hazardous additions

#### Dangerous components

117-81-7	bis(2-ethylhexyl) phthalate	 T; R 60-61	2.5-10%
1309-48-4	magnesium oxide		2.5-10%
1314-13-2	zinc oxide		2.5-10%
68953-84-4	N,N'-Diaryl-p-phenyldiamine	 Xi,  N; R 43-50/53	≤ 1.0%
97-39-2	1,3-di-o-tolylguanidine	 T; R 25	≤ 1.0%

**Additional information:** For the wording of the listed risk phrases refer to section 16.

### 5.12.3 Hazards identification

#### Hazard description U

**Information pertaining to particular dangers for man and environment:**

The product has been classified in accordance with EU directives / national laws respectively. In the version marketed, it presents no risk to the environment or to health. Following directive 67 / 54 8 EC, annex VI, point 9.3 it is not necessary to be labelled.

#### Classification system

The classification was made according to the latest editions of international substances lists and expanded upon from company and literature data.

#### NFPA ratings (scale 0 - 4)

Health = 0, Fire = 0, Reactivity = 0

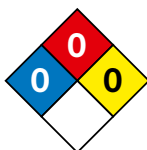

#### HMIS-ratings (scale 0-4)

Health = \*0, Fire = 0, Reactivity = 0

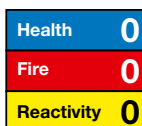

### 5.12.4 First aid measures

**General information:** No special measures required.

**After inhalation:** Supply fresh air; consult doctor in case of complaints.

**After skin contact:** Generally the product does not irritate the skin.

**After eye contact:** Rinse opened eye for several minutes under running water.

**After swallowing:** If symptoms persist consult doctor.

### 5.12.5 Fire fighting measures

**Suitable extinguishing agents:**

CO<sub>2</sub>, extinguishing powder or water spray. Fight larger fires with water spray or alcohol resistant foam.

**Special hazards caused by the material, its products of combustion or resulting gases:**

Formation of toxic gases is possible during heating or in case of fire.

In case of fire, the following can be released:

Carbon monoxide (CO), Sulphur dioxide (SO<sub>2</sub>), Hydrogen chloride (HCl)

**Protective equipment:** No special measures required.

### 5.12.6 Accidental release measures

**Person-related safety precautions:** Not required.

**Measures for environmental protection:** No special measures required.

**Measures for cleaning/collecting:** Pick up mechanically.

**Additional information:** No dangerous substances are released.

### 5.12.7 Handling and storage

**Handling**

**Information for safe handling:** No special measures required.

**Information about protection against explosions and fires:**

No special measures required.

**Storage**

**Requirements to be met by storerooms and receptacles:**

No special requirements.

**Information about storage in one common storage facility:** Not required.

**Further information about storage conditions:** None.

## 5.12.8 Exposure controls and personal protection

### Additional information about design of technical systems:

No further data; see item 7.

### Components with limit values that require monitoring at the workplace:

When working with the product N-nitrosamines can be liberated

#### 117-81-7 bis(2-ethylhexyl) phthalate

PEL	5 mg/m <sup>3</sup>
REL	Short-term value: 10 mg/m <sup>3</sup> Long-term value: 5 mg/m <sup>3</sup>
TLV	5 mg/m <sup>3</sup>

#### 1309-48-4 magnesium oxide

PEL	15* mg/m <sup>3</sup> fume
TLV	10 mg/m <sup>3</sup> fume

#### 1314-13-2 zinc oxide

PEL	15*; 5** mg/m <sup>3</sup> Dust only *Total dust **Respirable dust
REL	Short-term value: C 15*; 10** mg/m <sup>3</sup> Long-term value: 5, 5** mg/m <sup>3</sup> Zinc oxide, Dust only; *15-min Dust only; **Zinc
TLV	Short-term value: 10** mg/m <sup>3</sup> Long-term value: 10* 5** mg/m <sup>3</sup> *dust **fume; *NIC-2 R; *10 R; *(e)

### Additional information

The lists that were valid during formulation were used as a basis.

### Personal protective equipment

General protective and hygienic measures:

The usual precautionary measures for handling chemicals should be followed.

### Protection of hands

The glove material must be impermeable and resistant to the product / the substance / the preparation.

As no test information is available, no recommendation about glove material can be given for the product/ the preparation/ the chemical mixture.

Selection of the glove material on consideration of the penetration times, rates of diffusion and the degradation.

### Glove material

Selection of suitable gloves does not only depend on the material, but also on further marks of quality and varies from manufacturer to manufacturer. As the product is a preparation of several substances, the resistance of the glove material can not be calculated in advance and must therefore be checked prior to the application.

### Penetration time of glove material

The exact breakthrough time must be stated by the manufacturer of the protective gloves and must be observed.

### Eye protection

Not required.

### 5.12.9 Physical and chemical properties

#### General Information

<b>Form:</b>	Solid
<b>Color:</b>	According to product specification
<b>Odor:</b>	Characteristic
<b>Change in condition</b>	
<b>Melting point/melting range:</b>	Undetermined.
<b>Boiling point/boiling range:</b>	Undetermined.
<b>Flash point:</b>	Not applicable.
<b>Ignition temperature:</b>	370.0°C (698°F)
<b>Auto igniting:</b>	Product is not self-igniting.
<b>Danger of explosion:</b>	Product does not present an explosion hazard.
<b>Density at 20°C (68°F):</b>	1.380 g/cm <sup>3</sup>
<b>Solubility in / miscibility with water:</b>	
	Insoluble.
<b>Solvent content:</b>	
<b>Organic solvents:</b>	0.0 %
<b>Solids content:</b>	94.5 %

### 5.12.10 Stability and reactivity

#### Thermal decomposition / conditions to be avoided

No decomposition if used according to specifications.

#### Dangerous reactions

No dangerous reactions known.

#### Dangerous products of decomposition

Hydrogen chloride (HCl)

Toxic pyrolysis products.

### 5.12.11 Toxicological information

#### Acute toxicity

#### LD/LC50 values that are relevant for classification

#### 117-81-7 bis(2-ethylhexyl) phthalate

Oral LD50 30600 mg/kg (rat)

Dermal LD50 25000 mg/kg (rbt)

#### Primary irritant effect

**On the skin:** No irritant effect.

**On the eye:** No irritating effect.

**Sensitization:** No sensitizing effects known.

#### Additional toxicological information

The product is not subject to classification according to internally approved calculation methods for preparations.

When used and handled according to specifications, the product does not have any harmful effects according to our experience and the information provided to us.

## 5.12.12 Ecological information

### General notes

Generally not hazardous to water

## 5.12.13 Disposal considerations

### Product

#### Recommendation

Smaller quantities can be disposed of with household waste.  
Can be disposed of under observance of the technical instructions after consultation with the local authorities and waste disposers.  
Use one of the following waste key numbers.

#### Uncleaned packagings

**Recommendation:** Disposal must be according to official regulations.

## 5.12.14 Transport information

---

#### DOT regulations:

**Hazard class:** -

---

#### Land transport ADR/RID (cross-border):

**ADR/RID class:** -

---

#### Maritime transport IMDG:

**IMDG Class:** -

**Marine pollutant:** No

---

#### Air transport ICAO-TI and IATA-DGR:

**ICAO/IATA Class:** -

---

#### Transport/additional information:

Not hazardous according to the above specifications.

## 5.12.15 Regulations

### Sara

#### Section 355 (extremely hazardous substances):

None of the constituents are listed.

#### Section 313 (Specific toxic chemical listings):

117-81-7 bis(2-ethylhexyl) phthalate

#### TSCA (Toxic Substances Control Act):

9010-98-4 Polychloropren CR

117-81-7 bis(2-ethylhexyl) phthalate

1309-48-4 magnesium oxide

1314-13-2 zinc oxide

97-39-2 1,3-di-o-tolylguanidine

101-67-7 bis(4-octylphenyl)amine

97-74-5 tetramethylthiuram monosulphide

### Proposition 65

#### Chemicals known to cause cancer:

117-81-7 bis(2-ethylhexyl) phthalate

#### Chemicals known to cause reproductive toxicity:

None of the constituents are listed.

### Carcinogeny categories

#### EPA (Environmental Protection Agency)

117-81-7 bis(2-ethylhexyl) phthalate B2

1314-13-2 zinc oxide D

#### IARC (International Agency for Research on Cancer)

117-81-7 bis(2-ethylhexyl) phthalate 2B

#### NTP (National Toxicology Program)

117-81-7 bis(2-ethylhexyl) phthalate R

#### TLV (Threshold Limit Value established by ACGIH)

117-81-7 bis(2-ethylhexyl) phthalate A3

#### MAK (German Maximum Workplace Concentration)

None of constituents are listed.

#### NIOSH-Ca (National Institute for Occupational Safety and Health)

117-81-7 bis(2-ethylhexyl) phthalate

#### OSHA-Ca (Occupational Safety & Health Administration)

None of the constituents are listed.

### Product-related hazard information

Observe the general safety regulations when handling chemicals.

The product has been classified in accordance with EU directives / national laws respectively.

In the version marketed, it presents no risk to the environment or to health.

Following directive 67 / 548 EC, annex VI, point 9.3 it is not necessary to be labelled.

## Hazard symbols

## U

### National regulations

### Technical instructions (air)

Class	Share in %
I	0.4
NK	5.5

**Water hazard class:** Generally not hazardous to water.

### Other regulations, limitations and prohibitive regulations

Subject to the regulations for N-Nitrosamines.

## 5.12.16 Other information

This information is based on our present knowledge. However, this shall not constitute a guarantee for any specific product features and shall not establish a legally valid contractual relationship.

**Department issuing MSDS:** Conseo GmbH Abteilung Umweltschutz

**Contact:** Hr. Dr. Kräßig / Hr. Dr. Laugwitz

## 6. Approvals

### 6.1 American Bureau of Shipping (ABS)

Certificate Number: 03-HS369456/1-PDA



## *Confirmation of Type Approval*

This is to certify that, pursuant to the Rules of American Bureau of Shipping (ABS), on 24/APR/2007 the manufacturer of the below listed product held a valid Manufacturing Assessment (MA) and a valid Product Design Assessment (PDA) for the below listed product, entitling the product to type approval. The validity of the Manufacturing Assessment is dependent on satisfactory audits as required by the Rules. The Product Design Assessment is valid only for products intended for use on ABS classed vessels, MODUs or facilities which are in existence or under contract for construction on the date of the ABS Rules used to evaluate the Product.

For Date of ABS Rules used for evaluation; Please refer to the ABS Rules below.

This Confirmation of Product Type Approval is valid as of the date shown above for the below listed product.

ABS makes no representations regarding type approval of the Product for use on vessels, MODUs or facilities built after the date of the ABS Rules used for evaluation.

Due to wide variety of specifications used in the products ABS has evaluated for Type Approval, it is part of our contract that the Client has full responsibility for continued compliance with the evaluation standard, whether the standard is an ABS Rule or a non-ABS Rule. As specified in the ABS Rules, Unit Certification may be required in addition to Product Type Approval. Please refer to the "Service Restrictions" shown below to determine if Unit Certification is required for this product.

HILTI AG

Model Name(s): X-BT Threaded Fastener

**Presented to:**

HILTI AG  
Feldkircherstrasse 100  
Postfach 333  
Schaan  
FL-9494  
Liechtenstein

**Intended Service:**

For fastening of steel and aluminum materials to applicable base metals as recommended by the manufacturer in the "Hilti X-BT Threaded Fastener Specification Binder"

**Description:**

Stainless steel threaded studs and accessories whereby fastenings are made using powder actuated tools to drive the fasteners into their final position using a pre-drilled hole and without fully penetrating the base metal. Characteristics of the threaded stud are as follows: 1) Nominal Diameter of the Stud: 4.5 mm 2) Nominal Diameter of the Hole: 4.0 mm 3) Nominal Drilling Depth: 6.4 mm 4) Minimal Embedment: 4.0 mm 5) Maximum Embedment: 4.8 mm Note: The base metal is required to be 8mm (5/16") minimum thickness.

**Ratings:**

1. Service Temperature: -40° Celsius 2. Rated Loads: Base Metal of Carbon Steel S235 / A36 a) Allowable Pullout - 1.8kN / 405# b) Allowable Shear - 2.6kN / 584# c) Allowable Moment - 8.2Nm / 6.0ft-lb 3. Rated Loads: Base Metal of Carbon Steel S355 / Grade 50 and stronger a) Allowable Pullout - 2.3kN / 517# b) Allowable Shear - 3.4kN / 764# c) Allowable Moment - 8.2Nm / 6.0ft-lb

**Service Restrictions:**

Unit Certification is not required for this product. If the manufacturer or purchaser requests an ABS Certificate for compliance with a specification or standard, the specification or standard, including inspection standards and tolerances, must be clearly defined. 1) The Hilti X-BT fastenings are to be used for fastening various materials to base metals of carbon steel or stainless steel in offshore structures, in accordance with the "Hilti X-BT Threaded Fastener Specification Binder". 2) To



ensure that proper anchoring/fastening mechanisms take place, i.e. pressing and fusing, the following fastening tools as recommended by the manufacturer shall be used: a) Drill bit - TX-BT 4/7. b) Tool DX 351-BT(G). c) Power Load 6.8/11M Brown 3) Minimum base metal strengths are to be as follows: a) Carbon Steel : Ultimate Tensile Strength (fu) = 360 N/mm2 (53.53 ksi ) b) Stainless Steel : Ultimate Tensile Strength (fu) = 360 N/mm2 (53.53 ksi ) 4) The fasteners are to be installed using installation procedures as recommended by the manufacturer. 5) In general, type approved X-BT fasteners are not to be used for the following locations: a) On Structural members that are sensitive to stress patterns or variations b) In Areas where notch toughness is of paramount importance c) For attachment of structural fire protection insulation. d) On bulkheads/decks with a thickness less than 8 mm e) Watertight boundaries 6) Type approved X-BT fasteners, if installed in fire rated divisions, shall be installed without the washer. 7) In general, the Hilti X-BT fasteners may be used to fasten materials in areas where welding or drilling for bolting is permissible. It is recommended that the fasteners be installed no closer than 6 mm from the edge of a flange or cutout and no closer than 15 mm between fasteners. The following additional guidance is provided for applications on offshore structures: a) Acceptable applications: i) The securing of grating panels ii) The securing of checker plate iii) The securing of electrical cable trays iv) The securing of electrical cable clips v) The securing of joiner bulkhead tracks to plating in deck modules vi) The securing of light duty fixtures and light hangers b) Acceptable locations: i) On Topside Deck members and plating ii) On Deck Modules iii) On members and plating in non-tight bulkheads and flats of hulls iv) On members in longitudinal and transverse frames of hulls c) Applications or locations where special care is recommended (see d below): i) In members with significant thermal stresses ii) In highly stressed portions of members iii) In members subject to high, cyclic loads iv) Hangers for pipe systems with high thermal stresses v) Hangers for sprinkler systems d) The Hilti X-BT fasteners may be used for the applications where special care is recommended by following the manufacturer's recommendations and guidance and obtaining approval from the Ow

**Comments:** ABS approvals are generally based on the product test reports furnished by recognized institutions and laboratories, which may reflect specific local conditions. If any application is in a jurisdiction where the fasteners are subject to an approval process or where specific guidelines are to be followed, the approved technical data or the specific design guidelines shall be followed.

**Notes / Documentation:** This Product Design Assessment (PDA) is valid only for products intended for use on ABS classed vessels, MODUs or facilities which are in existence or under contract for construction on the date of the ABS Rules used to evaluate the Product.

**Term of Validity:** This Design Assessment Certificate number 03-HS369456/1-PDA, dated 23/Apr/2007 will expire on 22/Apr/2012 or at an earlier date should there be alterations to the product's design or changes to the referenced ABS Rules and other specifications, which affect the product. Product use on or after 1 January 2008, will be subject to compliance with the ABS Rules or specifications in effect when the vessel, MODU or facility is contracted. The product's acceptability on board ABS-classed vessels or facilities is defined in the service restrictions of this certificate.

**ABS Rules:** 2007 Steel Vessel Rules 1-1-4/7.7, 2006 MODU Rules 3-2-2/11; 4-3-3/5.9

**National Standards:**  
**International Standards:**  
**Government Authority:**  
**EUMED:**  
**Others:**

None



Manager, ABS Programs

ABS has used due diligence in the preparation of this certificate and it represents the information on the product in the ABS Records as of the date and time the certificate was printed. Type Approval requires Drawing Assessment, Prototype Testing and assessment of the manufacturer's quality assurance and quality control arrangements. Limited circumstances may allow only Prototype Testing to satisfy Type Approval. The approvals of Drawings and Products remain valid as long as the ABS Rule, to which they were assessed, remains valid. ABS cautions manufacturers to review and maintain compliance with all other specifications to which the product may have been assessed. Further, unless it is specifically indicated in the description of the product; Type Approval does not necessarily waive witnessed inspection or survey procedures (where otherwise required) for products to be used in a vessel, MODU or facility intended to be ABS classed or that is presently in class with ABS. Questions regarding the validity of ABS Rules or the need for supplemental testing or inspection of such products should, in all cases, be addressed to ABS.

## 6.1 American Bureau of Shipping (ABS)

Certificate Number: 03-HS369884/1-PDA



### *Confirmation of Type Approval*

This is to certify that, pursuant to the Rules of American Bureau of Shipping (ABS), on 29/MAY/2008 the manufacturer of the below listed product held a valid Manufacturing Assessment (MA) and a valid Product Design Assessment (PDA) for the below listed product, entitling the product to type approval. The validity of the Manufacturing Assessment is dependent on satisfactory audits as required by the Rules. The Product Design Assessment is valid only for products intended for use on ABS classed vessels, MODUs or facilities which are in existence or under contract for construction on the date of the ABS Rules used to evaluate the Product.

For Date of ABS Rules used for evaluation; Please refer to the ABS Rules below.

This Confirmation of Product Type Approval is valid as of the date shown above for the below listed product.

ABS makes no representations regarding type approval of the Product for use on vessels, MODUs or facilities built after the date of the ABS Rules used for evaluation.

Due to wide variety of specifications used in the products ABS has evaluated for Type Approval, it is part of our contract that the Client has full responsibility for continued compliance with the evaluation standard, whether the standard is an ABS Rule or a non-ABS Rule. As specified in the ABS Rules, Unit Certification may be required in addition to Product Type Approval. Please refer to the "Service Restrictions" shown below to determine if Unit Certification is required for this product.

#### HILTI AG

Model Name(s): Fasteners: X-BT M8-15-6-R, X-BT M10-24-6-R, X-BT W10-24-6-R, X-BT M8-15-6-SN12-R, X-BT M10-24-6 SN12-R, X-BT W10-24-6 SN12-R, Drilling Tool: XBT 4000-A & TX-BT 4/7 drills, Fastening Tool: DX 351-BT & DX 351-BTG

**Presented to:**

HILTI AG  
Feldkircherstrasse 100  
Postfach 333  
Schaan  
FL-9494  
Liechtenstein

**Intended Service:**

For fastening of fastened materials to base materials of carbon steel or stainless steel in the ship and shipbuilding environment.

**Description:**

Corrosion resistant steel threaded studs and accessories whereby fastening are made by using power actuated tools to drive the fasteners into their final positions through a pre-drilled hole and without having to penetrate the base materials, in a process of pressing and fusing.

**Ratings:**

Refer to "Hilti X-BT Threaded Fastener Specification Binder" for the recommended maximum loading in tension, shear, moment and torque, in association with the 'Conditions for recommended loads' specified therein.

**Service Restrictions:**

Unit certification is not required for this product. 1) The Hilti X-BT fastenings are to be used for fastening various materials to base metals of carbon/ stainless steel in ship structures, i.a.w. the "Hilti X-BT Threaded Fastener Specification Binder". 2) To ensure that proper anchoring/fastening mechanisms take place, i.e. pressing and fusing, the following fastening tools as recommended by the manufacturer shall be used: Drill bit: TX-BT 4/7, Fastening Tool: DX 351-BT & DX 351-BTG, Power Load 6.8/11M Brown. 3) Minimum base metal strengths are to be as follows: a) Carbon Steel: Ult.Tensile Strength (fu) = 360 N/mm<sup>2</sup> (53.53 ksi) b) Stainless

Steel: Ult. Tensile Strength (fu) = 360 N/mm<sup>2</sup> (53.53 ksi) 4) The fasteners are to be installed using installation procedures recommended by the manufacturer. 5) In general, type approved X-BT fasteners are not to be used for the following locations: a) On structural members that are sensitive to stress patterns or variations b) In areas where notch toughness is of paramount importance c) For attachment of structural fire protection insulation. d) On bulkheads/decks with a thickness less than 8 mm e) Watertight boundaries 6) Type approved X-BT fasteners, if installed in fire rated divisions, shall be installed without the washer. 7) In general, the Hilti X-BT fasteners may be used to fasten materials in areas where welding or drilling for bolting is permissible. It is recommended that fasteners be installed no closer than 6 mm from the edge of a flange or cutout and no closer than 15 mm between fasteners. The following additional guidance is provided for applications on ship structures: a) Acceptable applications: i) The securing of grating panels ii) The securing of checker plate iii) The securing of electrical cable trays iv) The securing of electrical cable clips v) The securing of joiner bulkhead tracks to plating in deck modules vi) The securing of light duty fixtures and light hangers b) Acceptable locations: i) On platform decks ii) On non-tight bulkheads. iii) On lower decks iv) On transverse side frames v) In superstructures and deckhouse bulkheads vi) Securing of items 7a (i-vi)) above and similar items in A-class boundaries. c) Applications or locations where special care is recommended (see d below): i) In members with significant thermal stresses ii) In highly stressed portions of members iii) In members subject to high, cyclic loads iv) Hangers for pipe systems with high thermal stresses v) Hangers for sprinkler systems d) The Hilti X-BT fasteners may be used for the applications where special care is recommended by following the manufacturer's recommendations and guidance and obtaining approval from the Owner and the attending Surveyor. 8) Hilti X-BT fasteners may also be used for applications other than those listed above, subject to specific engineering approval for the application prior to installation. See also the Guidance Notes for DX-fasteners(ship application)

**Comments:** ABS approvals are general based on the product test reports furnished by recognized institutions and laboratories which may reflect specific local conditions. If any application is in a jurisdiction where the fasteners are subject to the approval process or specific guidelines are to be followed, the approved technical data or design guidelines take precedence over technical data presented herein.

**Notes / Documentation:** This Product Design Assessment (PDA) is valid only for products intended for use on ABS classed vessels, MODUs or facilities which are in existence or under contract for construction on the date of the ABS Rules used to evaluate the Product.

**Term of Validity:** This Design Assessment Certificate number 03-HS369884/1-PDA, dated 13/May/2008 will expire on 12/May/2013 or at an earlier date should there be alterations to the product's design or changes to the referenced ABS Rules and other specifications, which affect the product. Product use on or after 1 January 2009, will be subject to compliance with the ABS Rules or specifications in effect when the vessel, MODU or facility is contracted. The product's acceptability on board ABS-classed vessels or facilities is defined in the service restrictions of this certificate.

**ABS Rules:** 2008 Steel Vessels Rule1-1-4/7.7, 4-8-4/21.9

**National Standards:**  
**International Standards:**  
**Government Authority:**  
**EUMED:**  
**Others:**

Manufacturer's standards



Manager, ABS Programs

ABS has used due diligence in the preparation of this certificate and it represents the information on the product in the ABS Records as of the date and time the certificate was printed. Type Approval requires Drawing Assessment, Prototype Testing and assessment of the manufacturer's quality assurance and quality control arrangements. Limited circumstances may allow only Prototype Testing to satisfy Type Approval. The approvals of Drawings and Products remain valid as long as the ABS Rule, to which they were assessed, remains valid. ABS cautions manufacturers to review and maintain compliance with all other specifications to which the product may have been assessed. Further, unless it is specifically indicated in the description of the product; Type Approval does not necessarily waive witnessed inspection or survey procedures (where otherwise required) for products to be used in a vessel, MODU or facility intended to be ABS classed or that is presently in class with ABS. Questions regarding the validity of ABS Rules or the need for supplemental testing or inspection of such products should, in all cases, be addressed to ABS.

## 6.2 Lloyd's Register



### Type Approval Certificate Extension

This is to certify that Certificate No. 03/00070 for the undernoted products is extended and renumbered as shown.

This certificate is issued to:

<b>PRODUCER</b>	Hilti Corporation
<b>PLACE OF PRODUCTION</b>	FL-9494 Schaan Principality of Liechtenstein
<b>DESCRIPTION</b>	Hilti X-BT direct mechanical fastening system, comprising Hilti fastening tool, drill bit and power loads.
<b>TYPE</b>	X-BT stainless steel threaded studs:  Threaded stud connections: X-BT M8-15-6-R X-BT M10-24-6-R X-BT W10-24-6-R X-BT M8-15-6 SN12-R X-BT M10 24-6 SN12-R X-BT W10-24-6 SN12-R  Composite fasteners: X-FCM-R
<b>APPLICATION</b>	For use in fastening to steel in marine, offshore and industrial environments.
<b>SPECIFIED STANDARDS</b>	Hilti X-BT Threaded Fastener Specification; Hilti Direct Fastening technology manual, Product Information.

**Certificate No.** 03/00070(E1)

**Issue Date** 2 November 2009

**Expiry Date** 8 June 2013

**Sheet** 1 of 2

  
P. F. Moysey  
London Design Support Services  
Lloyd's Register EMEA

Lloyd's Register EMEA  
71 Fenchurch Street, London EC3M 4BS

Lloyd's Register, its affiliates and subsidiaries and their respective officers, employees or agents are, individually and collectively, referred to in this clause as the 'Lloyd's Register Group'. The Lloyd's Register Group assumes no responsibility and shall not be liable to any person for any loss, damage or expense caused by reliance on the information or advice in this document or howsoever provided, unless that person has signed a contract with the relevant Lloyd's Register Group entity for the provision of this information or advice and in that case any responsibility or liability is exclusively on the terms and conditions set out in that contract.



**OTHER CONDITIONS**

This Type Approval certificate is to be read in conjunction with LR Technical Report no. 2003/CSG/TI/6331.

The minimum strength of the base material must be as stated in the Hilti X-BT Threaded Fastener Specification.

The end user must ensure that the base and fastened materials possess adequate corrosion resistance for the environments in which they are to be used.

*"This Certificate is not valid for equipment, the design, ratings or operating parameters of which have been varied from the specimen tested. The manufacturer should notify Lloyd's Register EMEA of any modification or changes to the equipment in order to obtain a valid certificate."*

*The attached Design Appraisal Document No. 03/00070(E1) and its supplementary Type Approval Terms and Conditions form part of this Certificate.*

All other details remain as the previous Certificate No. 03/00070 to which this extension should be attached.

**Certificate No.** 03/00070(E1)  
**Issue Date** 2 November 2009  
**Expiry Date** 8 June 2013  
**Sheet** 2 of 2



P. F. Moysey  
 London Design Support Services  
 Lloyd's Register EMEA

Lloyd's Register EMEA  
 71 Fenchurch Street, London EC3M 4BS

Lloyd's Register, its affiliates and subsidiaries and their respective officers, employees or agents are, individually and collectively, referred to in this clause as the 'Lloyd's Register Group'. The Lloyd's Register Group assumes no responsibility and shall not be liable to any person for any loss, damage or expense caused by reliance on the information or advice in this document or howsoever provided, unless that person has signed a contract with the relevant Lloyd's Register Group entity for the provision of this information or advice and in that case any responsibility or liability is exclusively on the terms and conditions set out in that contract.

LLOYD'S REGISTER GROUP/ APPROVALS/ 03/00070

## 6.3 Germanischer Lloyd (GL)

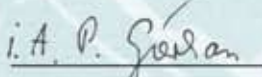
<h1>Approval Certificate</h1>		
This is to certify, that the undemoted products have been approved in accordance with the relevant requirements of the GL Approval System.		
Certificate No.	12 272 - 10 HH	
Company	Hilti Aktiengesellschaft PO Box 333 9494 Schaan, LIECHTENSTEIN	
Product	MECHANICAL FASTENING SYSTEMS	
Type	HILTI X-BT STAINLESS STEEL THREADED FASTENERS	
Technical Data / Application	<p>DESCRIPTION / TECHNICAL DATA</p> <p>Hilti X-BT mechanical fastening system, comprising fastening and drilling tools and stainless steel threaded studs and accessories whereby fastening are made by using pressing actuated tools to drive the fasteners into their final positions into a pre-drilled hole and without having to penetrate the base materials, in a process of pressing and fusing.</p> <p><b>X-BT FASTENING SYSTEM:</b>            Stainless steel threaded studs:            X-BT M8-15-6-R      X-BT M8-15-6 SN 12-R      Composite fasteners:            X-BT M10-24-6-R      X-BT M10-24-6 SN 12-R      X-FCM-R, X-FCM-M            X-BT W10-24-6-R      X-BT W10-24-6 SN 12-R            Drilling tool: XBT 4000-A drill, TX-BT 4/7 step drill bits            Fastening tools: DX 351 BTG for M8-types, DX 351 BT for M10/W10-types            Cartridge: 6.8/11M brown "High Precision"</p>	
Approval Standard	• Test processes in accordance with international recognized standards	
Documents	• Hilti X-BT Threaded Fastener Specification •	
Remarks	• Remarks / Limitations see page 2 •	
Valid until	2015-11-15	
File No.	XI.B.09	
<b>Germanischer Lloyd</b>		
Hamburg, 2010-10-18		
		
Michael Kämpf	Peter Gierhan	
Page 1 of 2		

# Approval Certificate



Certificate No. 12 272 - 10 HH

## RANGE OF APPLICATION

The above mentioned products may be used for fastening various materials to base metals of carbon / stainless steel in ship structures as follows:

- metal and fiberglass gratings to steel
- cable, conduit and tubing connectors to steel
- trays, channels and struts to steel for cable, conduit and tubing runs
- instrumentation, junction boxes, lighting
- pipe hangers
- signage
- door frames
- mounting cabinets, securing furniture, utensils, etc.

The fasteners may also be used for applications other than those listed above, subject to special consideration either by the local GL Surveyor or Germanischer Lloyd Head Office.

The minimum base material strengths are to be at least 360 N/mm<sup>2</sup>. The installation of the fasteners may be carried out in areas only where welding or drilling for bolting is permissible. Fasteners are not be installed no closer than 6 mm from the edge of a flange or cutout and no closer than 15 mm between fasteners.

## LIMITATION

The X-BT fasteners are not to be used for the following locations:

- on structural members requiring fatigue verification
- in areas where notch toughness may not be impaired
- for attachment of structural fire protection insulation
- on bulkheads and decks with a thickness less than 8 mm
- on the shell plating, sea chests and collision bulkheads

The selection of the HILTI X-BT Fastening System for the corresponding application and the proper assembly are to be in accordance with the instructions of the manufacturer and the current Rules of Germanischer Lloyd as applicable.

**Germanischer Lloyd**

Hamburg, 2010-10-18

  
Michael Kämpf

  
Peter Gierhan

## 6.4 Det Norske Veritas (DNV)



# DET NORSKE VERITAS

## TYPE EXAMINATION CERTIFICATE

**CERTIFICATE NO. S-5624**

This Certificate consists of 4 pages

*This is to certify that the*

**Structural Connecting Elements**

*with type designation(s)*

**X-BT M8-15-6-R; X-BT M10-24-6-R; X-BT W10-24-6-R;**

**X-BT M8-15-6 SN12-R; X-BT M10-24-6 SN12-R;**

**X-BT W10-24-6 SN12-R;**

**Grating Fastener X-FCM-R; Grating Fastener X-FCM-M**

*Manufactured by*

**Hilti Aktiengesellschaft**

Schaan, Liechtenstein

*is found to comply with*

Det Norske Veritas' Rules for Classification of Ships and Mobile Offshore Units

*Application*

Fastening applications in shipbuilding and offshore structures. Typical examples are fastening of grating, fire protection, cable trays and pipe hangers.

*Place and date*

Høvik, 2009-04-0202

for DET NORSKE VERITAS AS

*Astri Haukerud Gaarde*

Astri Haukerud Gaarde  
Head of Section



Local Office  
DNV Essen

*This Certificate is valid until*

2012-06-30

*Sjur Lassen*

Sjur Lassen  
Surveyor

**Notice: This Certificate is subject to terms and conditions overleaf. Any significant change in design or construction may render this Certificate invalid. The validity date relates to the Type Examination Certificate and not to the approval of equipment/systems installed.**

If any person suffers loss or damage which is proved to have been caused by any negligent act or omission of Det Norske Veritas, then Det Norske Veritas shall pay compensation to such person for his proved direct loss or damage. However, the compensation shall not exceed an amount equal to ten times the fee charged for the service in question, provided that the maximum compensation shall never exceed USD 2 million. In this provision "Det Norske Veritas" shall mean the Foundation Det Norske Veritas as well as all its subsidiaries, directors, officers, employees, agents and any other acting on behalf of Det Norske Veritas.





Cert. No.: S-5624  
File No.: 686.49

**Product description**

Powder actuated fastener with blunt tip with designation X-BT-R and grating fastening system X-FCM.

Description	Type designation
Threaded fastener	X-BT M8-15-6-R
Threaded fastener	X-BT M10-24-6-R
Threaded fastener	X-BT W10-24-6-R
Threaded fastener with sealing washer	X-BT M8-15-6 SN12-R
Threaded fastener with sealing washer	X-BT M10-24-6 SN12-R
Threaded fastener with sealing washer	X-BT W10-24-6 SN12-R
Grating Fastener, stainless steel	X-FCM-R 25/30
Grating Fastener, stainless steel	X-FCM-R 1¼ - 1½
Grating Fastener, stainless steel	X-FCM-R 35/40
Grating Fastener, stainless steel	X-FCM-R 45/50
Grating Fastener, carbon steel, duplex coated	X-FCM-M 25/30
Grating Fastener, carbon steel, duplex coated	X-FCM-M 1¼ - 1½
Grating Fastener, carbon steel, duplex coated	X-FCM-M 35/40
Grating Fastener, carbon steel, duplex coated	X-FCM-M 45/50
Hilti fastening tool	DX 351 BT
Hilti fastening tool	DX 351 BTG
Hilti drill bit	TX-BT 4/7
Hilti Powder Loads for X-BT fasteners	6.8/11M Brown

**Materials**

Material in shank is high strength austenitic stainless steel. The threaded sleeve and the sealing washer are made from standard type 316/316L austenitic stainless steel.

Description	Standard / Property requirement
Fastener shank	CR-500. Ultimate tensile, Rm > 1850 MPa
Fastener threaded sleeve and SN12-R washer	Stainless steel X2CrNiMo17132, X5CrNiMo17122
Fastener sealing washer	Black elastomer
Grating disk X-FCM-R	Disc: Stainless steel X2CrNiMo18143, X2CrNiMo17122 Threaded stem: Stainless steel X2CrNiMo17132, X5CrNiMo17122, X6CrNiMoTi17122
Grating disk X-FCM-M	Disc: Cold rolled carbon steel DC04 to EN 10130 Threaded stem: Bright (free cutting) steel 11SMnPb30+C to EN 10277. Disk and stem coated with duplex.



Cert. No.: S-5624  
File No.: 686.49

### Application/Limitation

Minimum base material thickness: 8mm  
Maximum base material thickness: no limit for X-BT using pre-drilled hole

Minimum yield strength of base material: 235 MPa

Design loads are given in the Hilti X-BT Threaded Fastener, Specification Binder, for two base material strengths; yield of 235MPa and yield of 355MPa. For the grating discs, different design loads are given for gratings with rectangular openings and square openings. Load ratings have been evaluated to meet the safety level requirement of DNV-OS-C101 and DNV-OS-C201.

For fatigue assessment of base material, the fatigue curve E in DNV-RP-C203 shall be used.

Installation of X-BT fasteners shall be performed according to procedures in the Hilti X-BT Threaded Fastener, Specification Binder. Pre-drilled hole shall be made with the TX-BT 4/7 step shank drill bit to ensure correct dimensions of hole. The minimum edge distance is 6mm. The maximum tightening torque of grating disc or a nut fitted to the threaded fastener is 8Nm.

### Type Approval documentation

Document title	Document number / Issue
HILTI. Hilti X-BT threaded fastener, Specification Binder	Edition 07/2003
HILTI. X-FCM Grating Fastening System, Data sheets	11/2007
Staatlich Autorisierte Bautechnische Versuchsanstalt. Test report about X-FCM-R and X-FCM grating discs loading capacity under pure tension and shear.	269/95
HILTI. Evaluation report on 5S-fastenings	XE_02_36, July 4 <sup>th</sup> 2002
HILTI. Experimental investigations on the effect of Hilti 5S-fasteners on the fatigue strength of structural steel.	XE_02_08, June 18 <sup>th</sup> 2002
HILTI. Investigations on the effect of dynamic base metal stresses (vibrations) on the pullout strength of Hilti 5S-fasteners.	XE_02_09, June 19 <sup>th</sup> 2002
HILTI. Investigations on the effect of base metal tensile stresses on the pullout strength of Hilti 5S-fasteners.	XE_02_10, June 20 <sup>th</sup> 2002
HILTI. Complementary evaluation report on X-BT-fastenings.	XE_03_01, January 14 <sup>th</sup> 2003



Cert. No.: S-5624  
File No.: 686.49

#### **Tests carried out**

Documentation of tests performed forming the basis for this type examination are referenced in the table above.

#### **Marking of product**

Marking shall consist of manufacturer's name or identification together with a type designation. The use of the DNV logo in relation to marketing and labelling of goods shall follow the procedures of DNV IS III-A3.

#### **Certificate retention survey**

For retention of the Type Examination, a DNV Surveyor shall perform a survey every second year and before the expire date of this certificate to verify that the conditions of the type examination are complied with.

END OF CERTIFICATE

## 6.5 ICC-ES



Most Widely Accepted and Trusted

### ICC-ES Evaluation Report

**ESR-2347**

Reissued December 1, 2009

This report is subject to re-examination in two years.

[www.icc-es.org](http://www.icc-es.org) | (800) 423-6587 | (562) 699-0543

A Subsidiary of the International Code Council®

#### DIVISION: 05—METALS

Section: 05090—Metal Fastenings

#### REPORT HOLDER:

HILTI, INC.  
5400 SOUTH 122<sup>ND</sup> EAST AVENUE  
TULSA, OKLAHOMA 74146  
(800) 879-8000  
[www.us.hilti.com](http://www.us.hilti.com)  
[HNATechnicalServices@hilti.com](mailto:HNATechnicalServices@hilti.com)

#### EVALUATION SUBJECT:

HILTI LOW-VELOCITY POWDER-ACTUATED DRIVEN  
THREADED STUDS FOR ATTACHMENT TO STEEL

#### 1.0 EVALUATION SCOPE

##### Compliance with the following codes:

- 2009 *International Building Code*® (2009 IBC)
- 2009 *International Residential Code*® (2009 IRC)
- 2006 *International Building Code*® (2006 IBC)\*
- 2006 *International Residential Code*® (2006 IRC)\*
- 2003 *International Building Code*® (2003 IBC)\*
- 2003 *International Residential Code*® (2003 IRC)\*
- 2000 *International Building Code*® (2000 IBC)\*
- 2000 *International Residential Code*® (2000 IRC)\*
- 1997 *Uniform Building Code*™ (UBC)\*

\*Codes indicated with an asterisk are addresses in Section 8.0

##### Property evaluated:

Structural

#### 2.0 USES

The Hilti Powder-Actuated Driven Threaded Studs are used as alternatives to the bolts used to attach materials to structural steel, which are described in IBC Section 2204.2. The fasteners may be used for structures regulated under the IRC, when an engineered design is submitted in accordance with IRC Section R301.1.3.

#### 3.0 DESCRIPTION

##### 3.1 General:

Hilti low-velocity powder-actuated threaded studs are fasteners with male threads for attachment on one end and a pointed- or blunt-tip shank on the other end for

embedding into the supporting steel. Both types may be supplied with a plastic washer for the carbon steel fasteners or a stainless steel washer for the stainless steel fasteners. The threaded studs with pointed-tip shanks are driven directly into the steel. The threaded studs with blunt-tip shanks (X-BT type) are driven into a predrilled pilot hole. The threaded studs are available with the thread designations and lengths and in the materials shown in Table 1. See Figures 1 and 2 for illustrations of pointed- and blunt-tip shank threaded studs.

##### 3.2 Materials:

Carbon steel threaded studs are manufactured from hardened steel and are zinc-plated in accordance with ASTM B 633 SC 1, Type III. Stainless steel threaded studs are composed of two main parts, the threaded sleeve and the drive pin. The threaded sleeve and washer are manufactured from SAE 316 stainless steel. The drive pin is manufactured from a proprietary CrNiMo alloy complying with the requirements of SAE 316.

##### 3.3 Steel Substrates:

Structural steel must comply with ASTM A 36 and have minimum thicknesses as shown in Tables 2 and 3.

#### 4.0 DESIGN AND INSTALLATION

##### 4.1 Design:

**4.1.1 General:** The allowable shear and tension service loads for the threaded studs installed in steel are found in Tables 2 and 3. The allowable loads or load combinations for the fasteners are not allowed to be adjusted for fasteners subjected to wind loads. Except for fasteners used with architectural, electrical and mechanical components as described in Section 13.1.4 of ASCE/SEI 7, use of fasteners to resist earthquake loads is outside the scope of this report.

Allowable loads for fasteners subjected to combined shear and tension forces are determined by the following formula:

$$(P_s/P_t) + (V_s/V_t) \leq 1$$

where:

- $P_s$  = Applied service tension load, pounds (N).
- $P_t$  = Allowable service tension load, pounds (N).
- $V_s$  = Applied service shear load, pounds (N).
- $V_t$  = Allowable service shear load, pounds (N).

**4.1.2 Wood to Steel Connections:** Reference lateral design loads for fasteners determined in accordance with Part 11 of ANSI/AF&PA NDS-2005 are applicable to Hilti

ICC-ES Evaluation Reports are not to be construed as representing aesthetics or any other attributes not specifically addressed, nor are they to be construed as an endorsement of the subject of the report or a recommendation for its use. There is no warranty by ICC Evaluation Service, Inc., express or implied, as to any finding or other matter in this report, or as to any product covered by the report.

Copyright © 2009



Page 1 of 5

fasteners of equal or greater diameters. The wood element must be considered to be the side member. The fastener bending yield strength is allowed to be taken as the value noted in the NDS, based on the fastener diameter.

#### 4.2 Installation:

**4.2.1 General:** The powder-actuated threaded studs must be installed in accordance with this report and the manufacturer's published installation instructions. A copy of these instructions must be available on the jobsite at all times during installation. Installation is limited to dry, interior locations, except for stainless steel fasteners, which may be installed in exterior or damp environments.

Fastener placement requires the use of a Hilti low-velocity powder-actuated tool in accordance with Hilti recommendations. Threaded studs must be installed with stud stand-off,  $h_{NVS}$ , dimensions as defined in Figure 3 and Table 1. Minimum spacing between fasteners must be 1 inch (25.4 mm) and minimum edge distance must be  $\frac{1}{2}$  inch (12.7 mm). Installers must be certified by Hilti and have a current, Hilti-issued, operator's license.

**4.2.2 X-BT Blunt-tip Threaded Studs:** The X-BT blunt-tip threaded studs require a pilot hole predrilled to the required depth with a Hilti TX-BT 4/7 step shank drill bit, in accordance with the manufacturer's published installation instructions. Installation instructions for the X-BT threaded studs are illustrated in Figure 5.

#### 5.0 CONDITIONS OF USE

The Hilti Low-Velocity Powder-Actuated Driven Threaded Studs described in this report comply with, or are suitable alternatives to what is specified in, those codes listed in Section 1.0 of this report, subject to the following conditions:

- 5.1 The fasteners are manufactured and identified in accordance with this report.
- 5.2 Fastener installation complies with this report and the Hilti, Inc., published instructions. In the event of conflict between this report and the Hilti, Inc., published instructions, this report governs.
- 5.3 Allowable tension and shear values are as noted in this report. The stress increases and load reductions described in IBC Section 1605.3.2 are not allowed for wind loads acting alone or when combined with gravity loads. No increase is allowed for vertical loads acting alone.
- 5.4 Calculations demonstrating that the applied loads are less than the allowable loads described in this report must be submitted to the code official for approval. The calculations are to be prepared by a registered design professional where required by the statutes of the jurisdiction in which the project is constructed.
- 5.5 Except for fasteners used with architectural, electrical and mechanical components as described in Section 13.1.4 of ASCE/SEI 7, use of fasteners to resist earthquake loads is outside the scope of this report.
- 5.6 Stainless steel threaded studs may be installed in exterior, damp environments. Use of carbon steel threaded studs is limited to dry, interior locations.
- 5.7 Hilti stainless steel threaded studs may be installed in contact with preservative-treated wood, as set forth in the applicable code. Use of carbon steel threaded studs in contact with preservative-treated or fire-retardant-treated wood is beyond the scope of this report.

#### 6.0 EVIDENCE SUBMITTED

Data in accordance with the ICC-ES Acceptance Criteria for Fasteners Power-driven into Concrete, Steel and Masonry Elements (AC70), dated October 2006.

#### 7.0 IDENTIFICATION

Each package of fasteners is labeled with the product designation, the manufacturer's name (Hilti), and the evaluation report number (ESR-2347). An "H", for Hilti, is imprinted on the head of each carbon steel threaded stud. An "HI" is imprinted on the head of each stainless steel threaded stud. These imprints are shown in Figure 4

#### 8.0 OTHER CODES

##### 8.1 Evaluation Scope:

In addition to the codes referenced in Section 1.0, the products in this report were evaluated for compliance with the requirements of the following codes:

- 2006 *International Building Code*® (2006 IBC)
- 2006 *International Residential Code*® (2006 IRC)
- 2003 *International Building Code*® (2003 IBC)
- 2003 *International Residential Code*® (2003 IRC)
- 2000 *International Building Code*® (2000 IBC)
- 2000 *International Residential Code*® (2000 IRC)
- 1997 *Uniform Building Code*™ (UBC)

##### 8.2 Uses:

The Hilti Powder-Actuated Driven Threaded Studs are used as alternatives to the bolts used to attach materials to structural steel, as described in 2006 and 2003 IBC Section 2204.2, 2000 IBC Section 2209, and UBC Section 2205.11. The fasteners may be used for structures regulated under the IRC, when an engineered design is submitted in accordance with 2006 and 2003 IRC Section R301.1.3 or 2000 IRC Section R301.1.2, as applicable.

##### 8.3 Description:

See Section 3.0

##### 8.4 Design and Installation:

**8.4.1 Design:** See Section 4.1.1, with the following modifications:

- The stress increases and load reductions described in Section 1605.3 of the 2006, 2003 and 2000 IBC, and the stress increases described in Section 1612.3.2 of the UBC, are not allowed for wind loads acting alone or when combined with gravity loads. No increase is allowed for vertical loads acting alone.
- Except for fasteners used with architectural, electrical and mechanical components as described in Section 13.1.4 of ASCE/SEI 7-05 (2006 IBC and IRC), Section 9.6.1 of ASCE/SEI 7-02 (2003 IBC and 2003 IRC) or Section 9.6.1 of ASCE/SEI 7-98 (2000 IBC and 2000 IRC), use of fasteners to resist earthquake loads is outside the scope of this report.

See Section 4.1.2, with the following modification:

- Reference lateral design loads for fasteners determined in accordance with Part 11 of ANSI/AF&PA NDS-2005 (2006 IBC and 2006 IRC), Part 11 of ANSI/AF&PA NDS-2001 (2003 IBC and 2003 IRC), Part 12 of ANSI/AF&PA NDS-1997 (2000 IBC and 2000 IRC), or Part XII of ANSI/NFoPA NDS-1991 (UBC), as applicable, are applicable to Hilti fasteners of equal or greater diameters.

**8.4.2 Installation:** See Section 4.2.

**8.5 Conditions of Use:**

See Section 5.0, and the following:

**8.5.1** Allowable tension and shear loads are as noted in Section 4.1.1. The stress increases and load reductions described in Section 1605.3 of the 2006, 2003 and 2000 IBC, and the stress increases described in Section 1612.3.2 of the UBC, are not allowed for wind loads acting alone or when combined with gravity loads. No increase is allowed for vertical loads acting alone.

**8.5.2** Except for fasteners used with architectural, electrical and mechanical components as described in

Section 13.1.4 of ASCE/SEI 7-05 (2006 IBC and IRC), Section 9.6.1 of ASCE/SEI 7-02 (2003 IBC and IRC) or Section 9.6.1 of ASCE/SEI 7-98 (2000 IBC and IRC), use of fasteners to resist earthquake loads is outside the scope of this report.

**8.6 Evidence Submitted:**

See Section 6.0.

**8.7 Identification:**

See Section 7.0.

TABLE 16 THREADED STUD DESCRIPTIONS

DESIGNATION	THREAD DESIGNATION	SHANK DIAMETER in. (mm)	NOMINAL THREAD LENGTH in. (mm)	NOMINAL SHANK LENGTH in. (mm)	MATERIAL <sup>2</sup>	THREADED STUD STAND-OFF, h <sub>NVS</sub> <sup>1</sup> in. (mm)
<b>Pointed-Tip</b>						
X-EW6H-11-9	UNC 1/4-inch	0.145 (3.7)	7/16 (11)	3/8 (9)	CS	3/8 ñ 1/2 ( 9.5 - 12.5)
X-EW6H-20-9	UNC 1/4-inch	0.145 (3.7)	3/4 (20)	3/8 (9)	CS	23/32 ñ 27/32 ( 18.5 - 21.5)
X-EW6H-28-9	UNC 1/4-inch	0.145 (3.7)	1 1/8 (28)	3/8 (9)	CS	1 1/16 ñ 1 5/32 (26.5 - 29.5)
X-EW6H-38-9	UNC 1/4-inch	0.145 (3.7)	1 1/2 (38)	3/8 (9)	CS	1 7/16 ñ 1 9/16 (36.5 - 39.5)
X-EM8H-11-12	Metric 8 mm	0.177 (4.5)	7/16 (11)	1/2 (12)	CS	7/16 ñ 5/8 (11.5 - 15.5)
X-EM8H-15-12	Metric 8 mm	0.177 (4.5)	5/8 (15)	1/2 (12)	CS	5/8 ñ 3/4 (15.5 - 19.5)
X-EM8H-25-12	Metric 8 mm	0.177 (4.5)	1 (25)	1/2 (12)	CS	1 ñ 1 5/32 (25.5 - 29.5)
X-EM8H-35-12	Metric 8 mm	0.177 (4.5)	1 3/8 (35)	1/2 (12)	CS	1 3/8 ñ 1 9/16 (35.5 - 39.5)
X-EW10H-30-14	UNC 3/8-inch	0.205 (5.2)	1 3/16 (30)	9/16 (14)	CS	1 3/32 ñ 1 7/32 (28.0 - 31.0)
X-CRM8-9-12	Metric 8 mm	0.158 (4.0)	3/8 (9)	1/2 (12)	SS	7/16 - 19/32 (11.0 ñ 15.0)
X-CRM8-15-12	Metric 8 mm	0.158 (4.0)	5/8 (15)	1/2 (12)	SS	5/8 - 25/32 (16.0 ñ 20.0)
<b>Blunt-Tip</b>						
X-BT M8-15-6	Metric 8 mm	0.177 (4.5)	5/8 (15)	1/4 (6)	SS	5/8 ñ 11/16 (15.7 - 16.8)
X-BT M8-15-6 SN12-R	Metric 8 mm	0.177 (4.5)	5/8 (15)	1/4 (6)	SS	5/8 ñ 11/16 (15.7 - 16.8)
X-BT W10-24-6	UNC 3/8-inch	0.177 (4.5)	15/16 (24)	1/4 (6)	SS	1 - 1 1/16 (25.7 ñ 26.8)
X-BT W10-24-6 SN12-R	UNC 3/8-inch	0.177 (4.5)	15/16 (24)	1/4 (6)	SS	1 - 1 1/16 (25.7 ñ 26.8)
X-BT M10-24-6	Metric 10 mm	0.177 (4.5)	15/16 (24)	1/4 (6)	SS	1 - 1 1/16 (25.7 ñ 26.8)
X-BT M10-24-6 SN12-R	Metric 10 mm	0.177 (4.5)	15/16 (24)	1/4 (6)	SS	1 - 1 1/16 (25.7 ñ 26.8)

<sup>1</sup>See Figure 3 for depiction of h<sub>NVS</sub>.  
<sup>2</sup>CS = Carbon steel, SS = Stainless steel.

TABLE 26 ALLOWABLE LOADS FOR POINTED-TIP THREADED STUDS DRIVEN INTO STEEL <sup>1,2,3</sup> (lbf)

Fastener	Shank Dia. (in.)	Steel Thickness (in.)									
		3/16		1/4		3/8		1/2		≥ 3/4	
		Tension	Shear	Tension	Shear	Tension	Shear	Tension	Shear	Tension	Shear
X-EW6H	0.145	360	500	500	600	500	600	500	600	-	-
X-EM8H	0.177	-	-	700	700	700	700	700	700	-	-
X-EW10H	0.205	-	-	970	1000	1100	1100	1100	1100	800	800
X-CRM8	0.158	-	-	405	405	405	405	405	405	-	-

For SI: 1 inch = 25.4 mm, 1 lbf = 4.4 N, 1 psi = 6895 Pa.

Notes:

<sup>1</sup>The tabulated allowable load values are for the threaded studs only. Wood or steel members connected to the substrate must be investigated in accordance with accepted design criteria.

<sup>2</sup>Tabulated allowable load values based upon embedment in steel such that threaded stud stand-off, h<sub>NVS</sub>, complies with Table 1.

<sup>3</sup>All allowable load capacities above are based on base steel complying with ASTM A 36, with minimum yield strength (F<sub>y</sub>) of 36 ksi and minimum tensile strength of 58 ksi.

TABLE 3—ALLOWABLE LOADS FOR BLUNT-TIP (X-BT) THREADED STUDS DRIVEN INTO STEEL ≥ 5/16 INCH THICK <sup>1,2,3,4</sup> (lbf)

Fastener	Shank Dia. (in.)	Tension	Shear
X-BT M8, X-BT M10, or X-BT W10	0.177	405	585

For SI: 1 inch = 25.4 mm, 1 lbf = 4.4 N, 1 psi = 6895 Pa.

Notes:

<sup>1</sup>The tabulated allowable load values are for the threaded studs only. Wood or steel members connected to the substrate must be investigated in accordance with accepted design criteria.

<sup>2</sup>Tabulated allowable load values based upon embedment in steel such that threaded stud stand-off,  $h_{NVS}$ , complies with Table 1.

<sup>3</sup>All allowable load capacities above are based on base steel complying with ASTM A 36, with minimum yield strength ( $F_y$ ) of 36 ksi and minimum tensile strength of 58 ksi.

<sup>4</sup>Installation of fasteners must be in accordance with Section 4.2.2 and Figure 5 of this report.

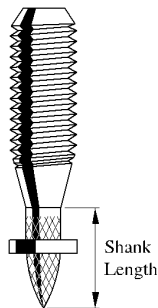

FIGURE 1—POINTED-TIP THREADED STUD

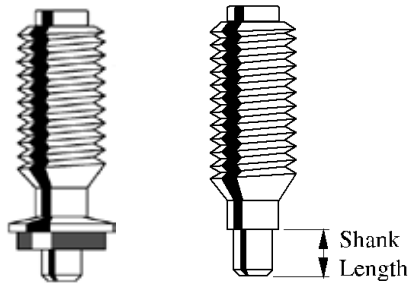

FIGURE 2—HILTI X-BT BLUNT-TIP THREADED STUD WITH AND WITHOUT SNR12-R SEALING WASHER

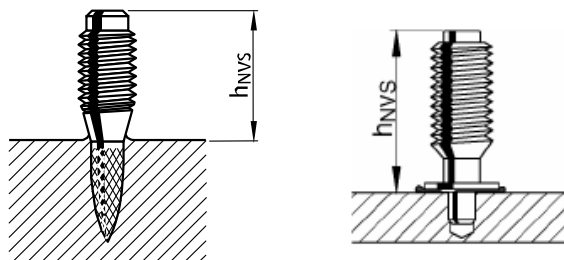
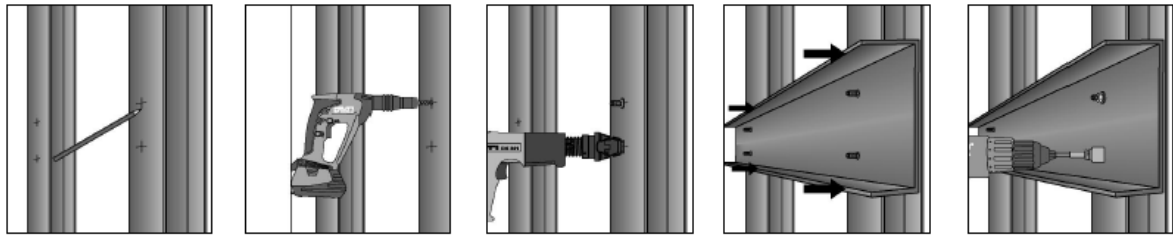

FIGURE 3—DEPICTION OF THREADED STUD STAND-OFF,  $h_{NVS}$ , FOR POINTED-TIP AND BLUNT-TIP THREADED STUDS



FIGURE 4—DEPICTION OF IDENTIFYING HEAD STAMP FOUND ON TOP OF THREADED STUDS: "H" FOUND ON CARBON STEEL STUDS AND "HI" FOUND ON STAINLESS STEEL STUDS



1. Mark location for each fastening
2. Pre-drill with TX-BT 4/7 step shank drill bit
3. Drive fastener into drilled hole only with DX351-BT/BTG tool and Hilti 6.8/11M High Precision brown cartridge or equivalent. High precision cartridge is a cartridge with a specific energy level and a narrow energy band.
4. Put on material to be fastened, washer and nut
5. Tighten using an electric screw driver with torque clutch

**Installation Details**

Pre-drill until shoulder grinds a shiny ring (to assure proper drilling depth).

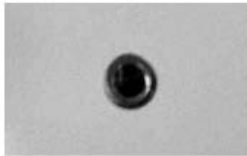

**Before fastener installation:**

The drilled hole must be clear of liquids and debris. Area around drilled hole must be free from liquids and debris.

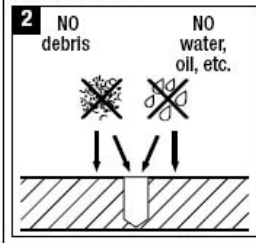

Adjust power on the DX351-BT/BTG so that the fastener standoff,  $h_{NVS}$ , is:

Fastener	$h_{NVS}$
X-BT M10-24-6-R	1.012"–1.055" (25.7–26.8 mm)
X-BT W10-24-6-R	1.012"–1.055" (25.7–26.8 mm)
X-BT M8-15-R	0.618"–0.661" (15.7–16.8 mm)

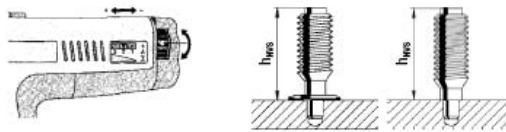

Proper compression of the sealing washer must be achieved.



Power regulation guide to check fastener standoff available from Hilti.

Tightening torque,  
 $T_{max} = 5.9 \text{ ft-lb (8 Nm)}$

Hilti Tool	Torque Setting <sup>1</sup>
SF 121-A	11
SF 150-A	9
SF 180-A	8

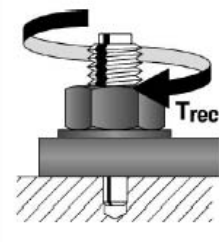

<sup>1</sup> Guideline setting only. Set clutch to appropriate setting to obtain desired torque.

FIGURE 5—INSTALLATION INSTRUCTIONS FOR HILTI X-BT THREADED STUDS



## 7. Customer testimonials

### Comments from satisfied users

“We use Hilti X-BT and grating fasteners to save time. The installation itself is much quicker (than alternative methods), in addition to this we save time by not damaging the coating.

Hilti X-BT threaded stud is easy to use and has many applications.

We are using X-BT to fasten:

- grating
- sound reduction plates
- fire extinguisher equipment
- light cable supports
- sign supports

These applications save us installation time. When the alternative is welding, the installation takes more time. One benefit is time and cost saving through avoiding coating damages.”

**Bjørn Helle**  
**Work preparations**  
**Aker Soltuions, Norway**

“After using the system we observed substantial gains in our efficiency. Our application is fixing cable trays to 10mm thick beams, normally our approach would have been to drill holes, which is time consuming and fix brackets with nuts, washers and bolts. With the X-BT (it is) one shot into the beam followed by fixing the bracket. A 2.5 meters long beam with 6 holes would normally take 2 hours to complete... with X BT it took 17 minutes on average!”

**Joel Cortejo**  
**E&I supervisor**  
**MIS Dubai**

“Following our subsea activities on the yard of WARRI in Nigeria, I've recommended the use of your material XBT to avoid the painful rework (welding/painting, back and forth) for project USAN (TOTAL). Your material was also used for the winch of installation of the risers of the TOTAL FPSO of MOHO BILONDO (direct line for TOTAL).”

**Raymond Guillaume**  
**Chief Engineer**  
**Acergy, France**





**Hilti. Outperform. Outlast.**

Hilti Corporation | 9494 Schaan | Liechtenstein | P +423-234 2111 | F +423-234 2965 | [www.hilti.com](http://www.hilti.com)